

TYLÖ SAUNA EVOLVE TRADITION

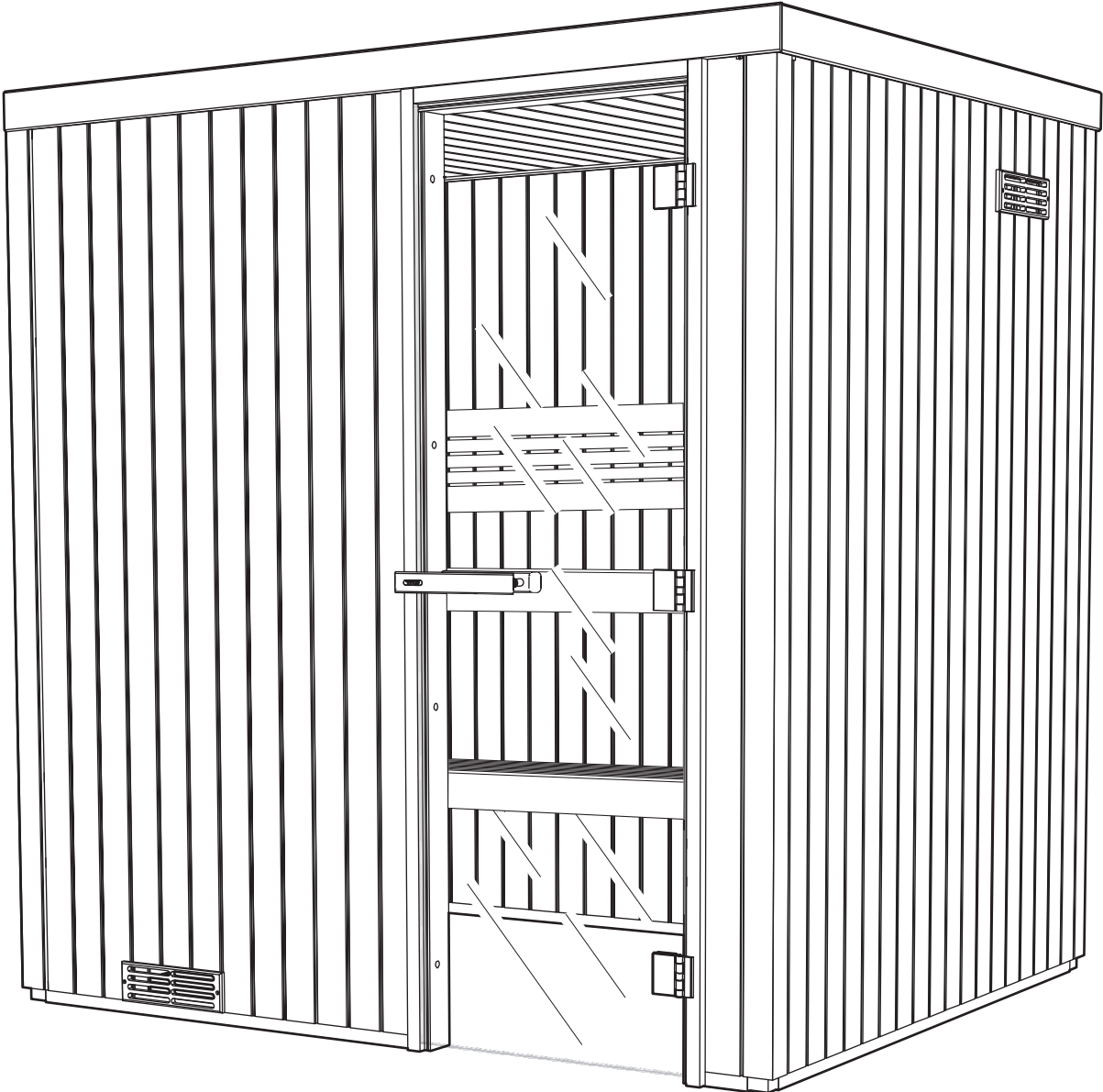

Väggsektion för aggregat

Wall section for heater

Moduł ścianki do montażu pieca do sauny

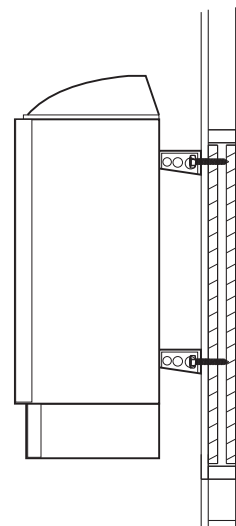
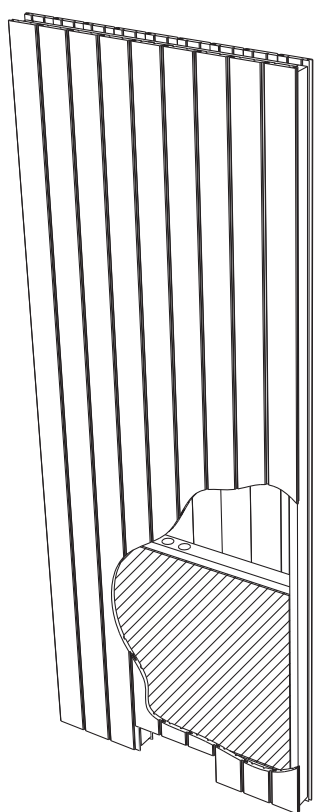
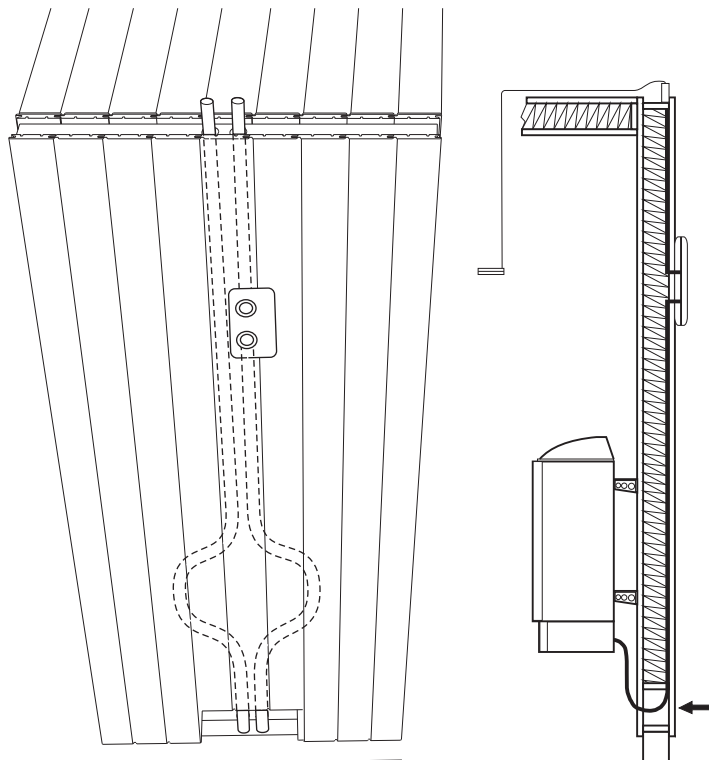
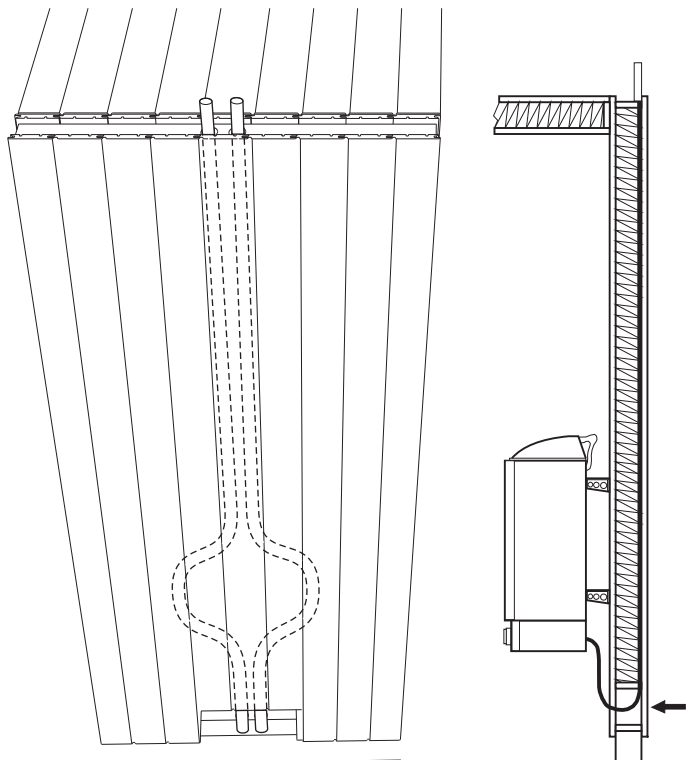

Tips!
Tip!
Porada!

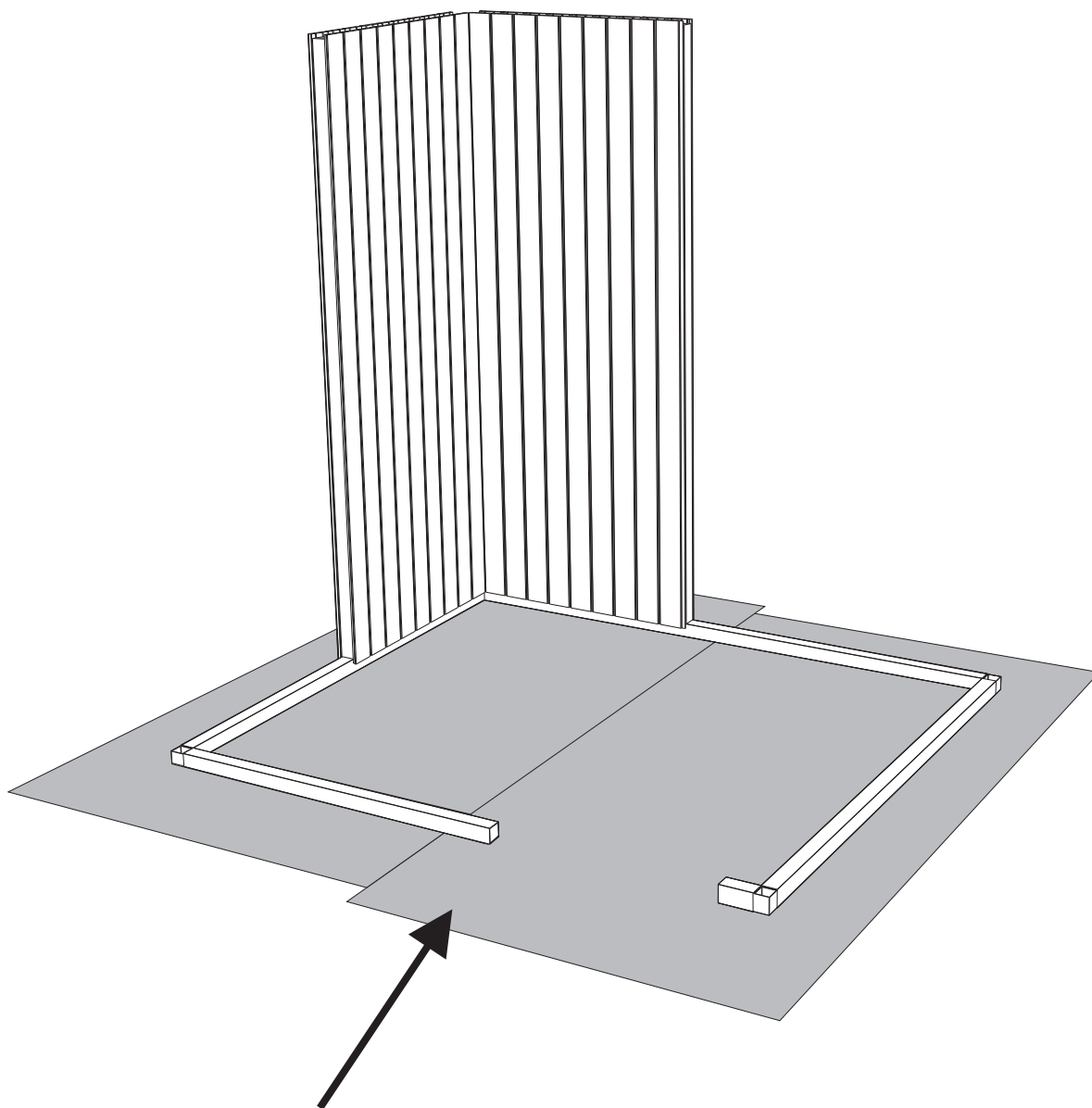

Rumsemballage

Använd som skydd på golvet vid montering av rummet.

Room packaging

Use as a protection on the floor during assembly of the room.

Opakowanie sauny

Można wykorzystać jako ochronę podłogi podczas montażu sauny.

OBS! Denna instruktionen kan skilja sig jämfört med bastun som är levererad.
Rummet som monteras i denna manual är ett Sauna E1917 Tradition.
Se layouten som medföljer rummet för mer detaljer.

Note! This instruction can differ from the room that is delivered.
The room that is mounted in this manual is a Sauna E1917 Tradition.
See the layout that comes with the sauna room for details.

1



Bild 2-7 visar hur hörnstolpar och väggar skall monteras om det inte finns utrymme för att skruva ihop dessa utifrån. Monteringsbleck används då.

Finns det utrymme rekommenderas att hörnstolpar och väggar skruvas ihop. Detta visas från bild 8.

Figure 2-7 shows how the corner posts and walls must be fitted if there is no space for screwing them together outside. Mounting plate is used then.

If there is space it's recommended that the corner posts and walls are screwed together. This is shown from figure 8.

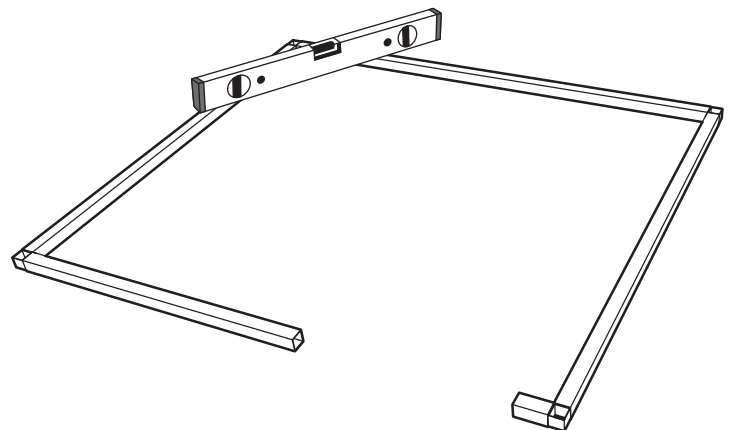
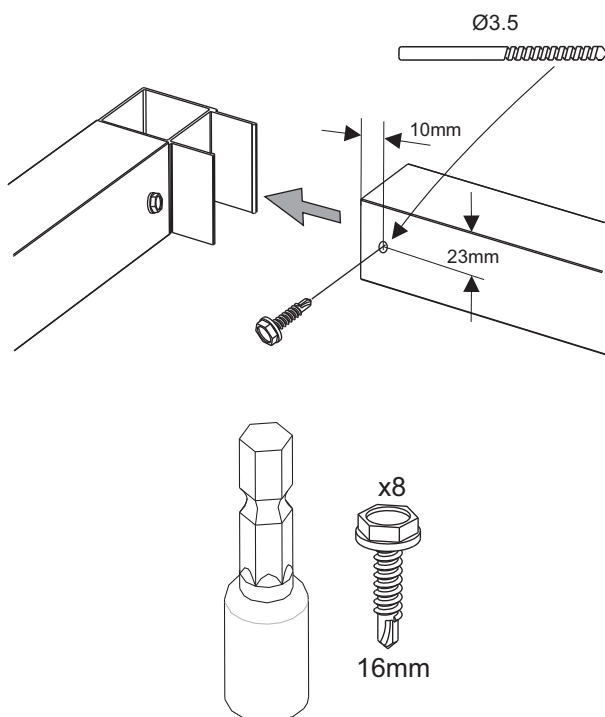
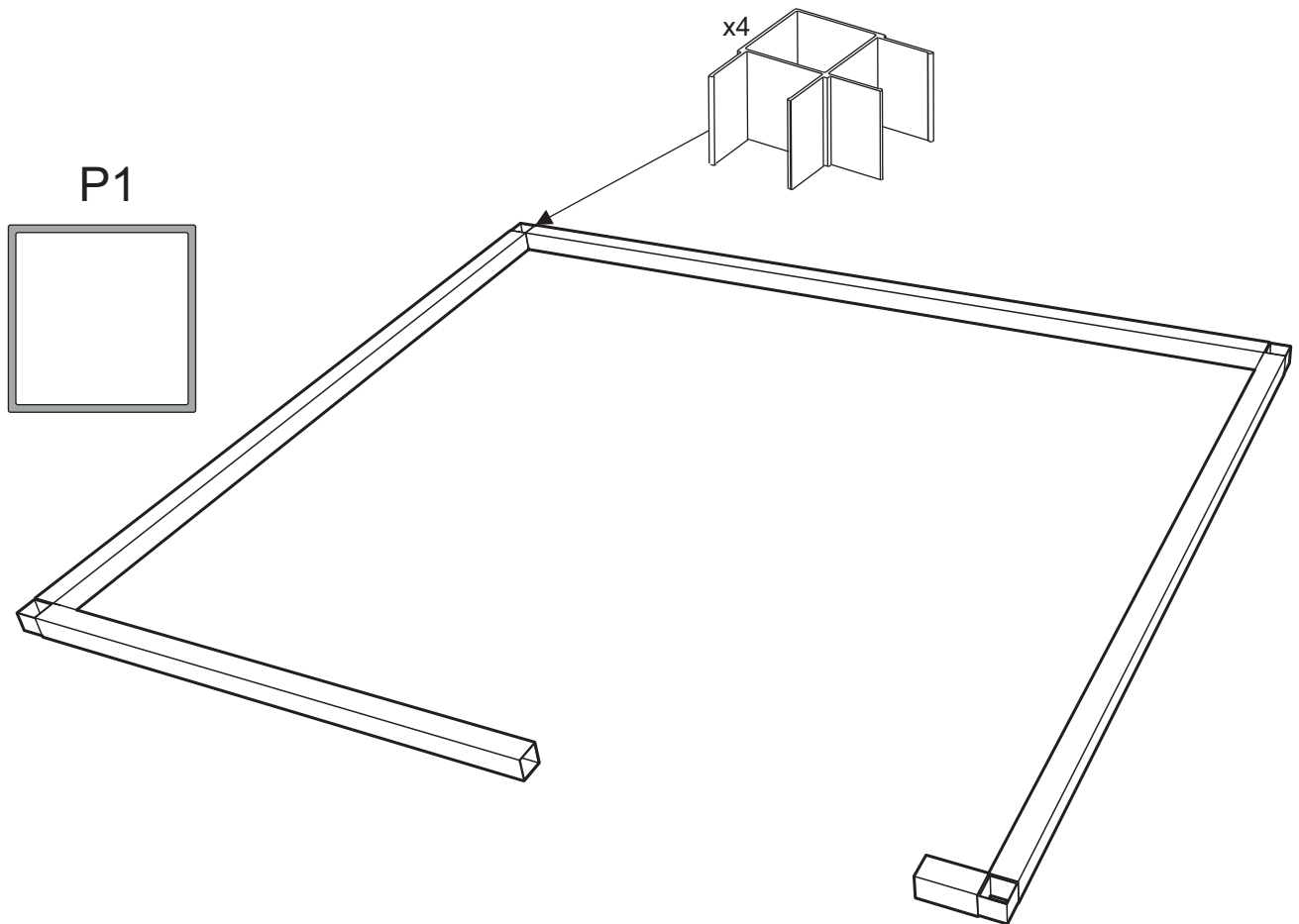
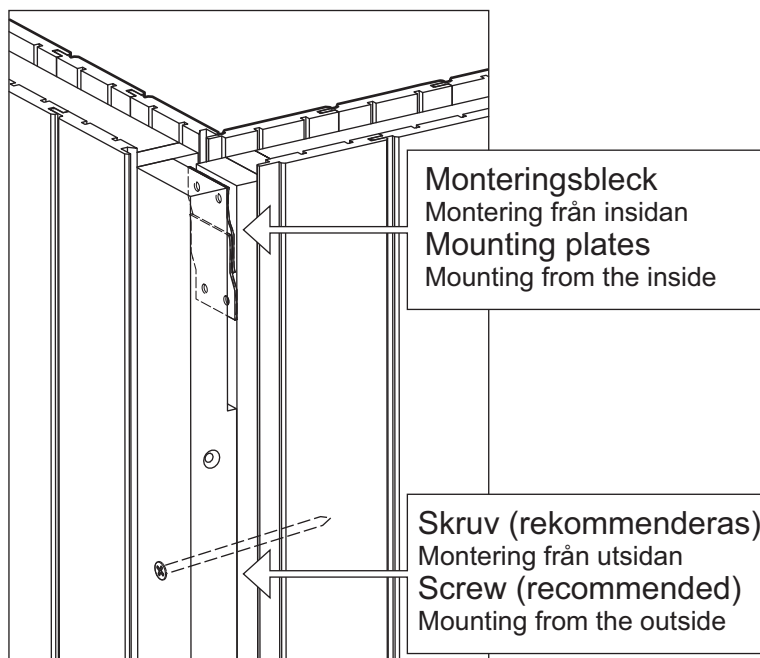

2 (Montering från insidan) (Mounting from the inside)

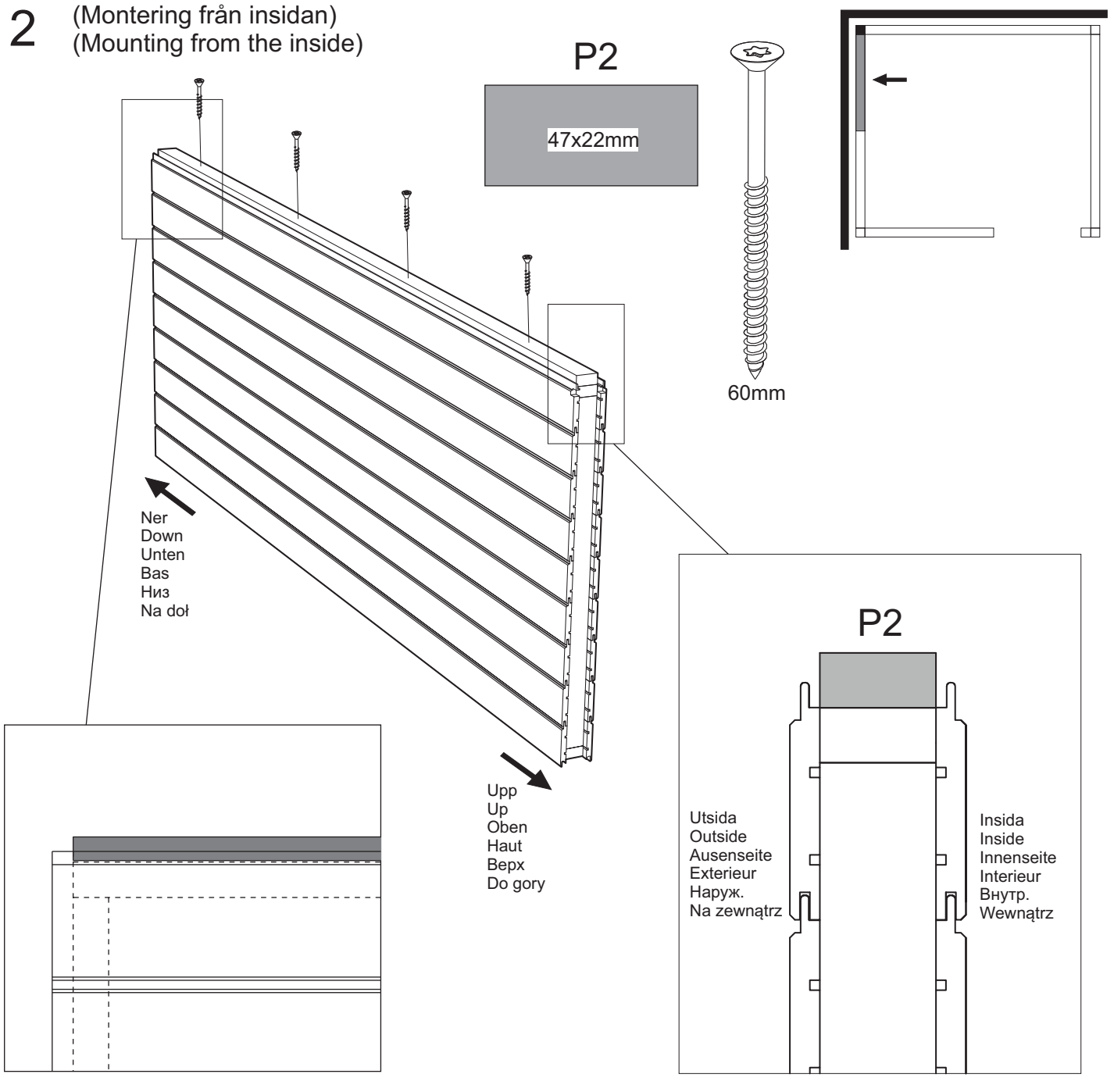

3 (Montering från insidan) (Mounting from the inside)

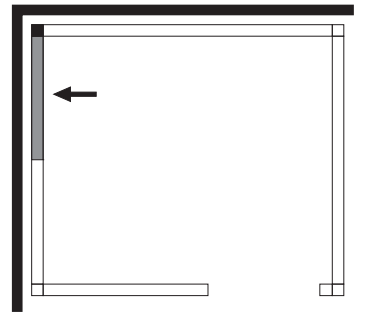
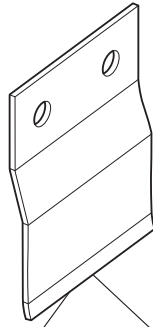
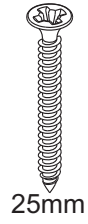
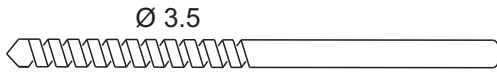

Använd medskickad mall
Use the enclosed template

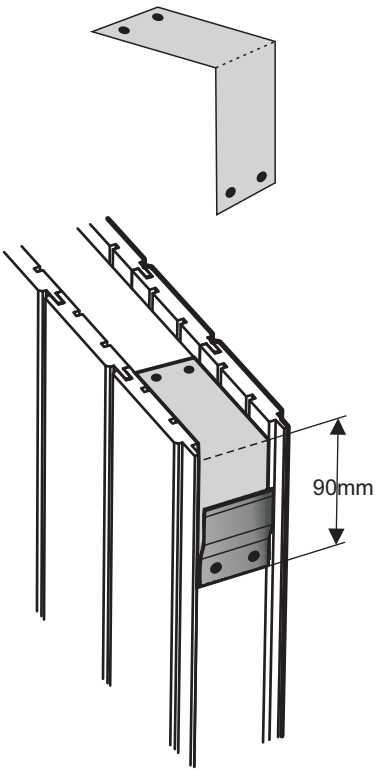

Ner
Down
Unten
Bas
Низ
Na doł

Upp
Up
Oben
Haut
Bepx
Do gory

Ner
Down
Unten
Bas
Низ
Na doł

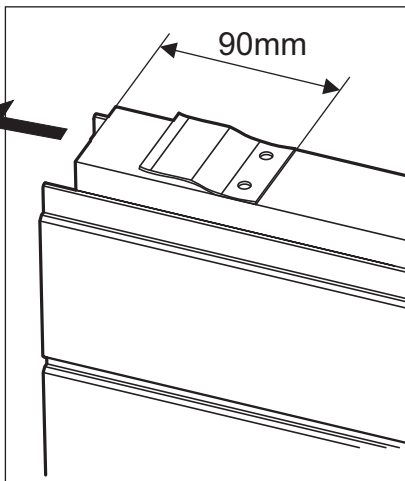

Upp
Up
Oben
Haut
Bepx
Do gory

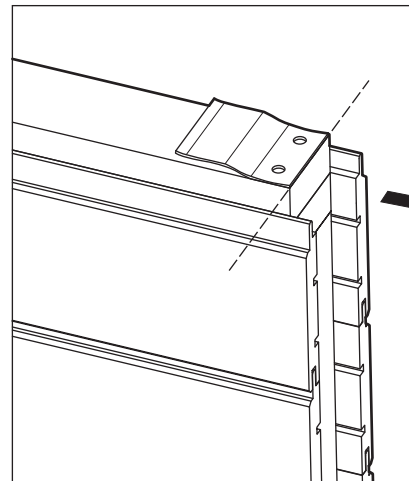

4 (Montering från insidan)
(Mounting from the inside)

P3

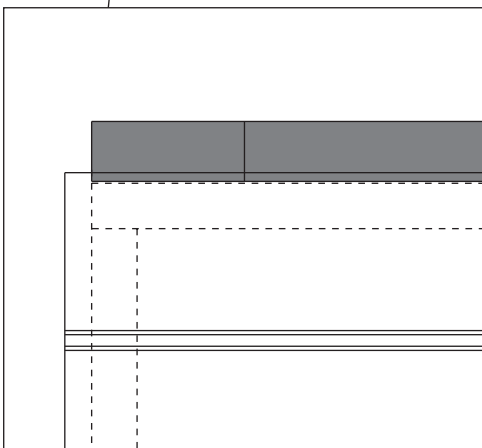
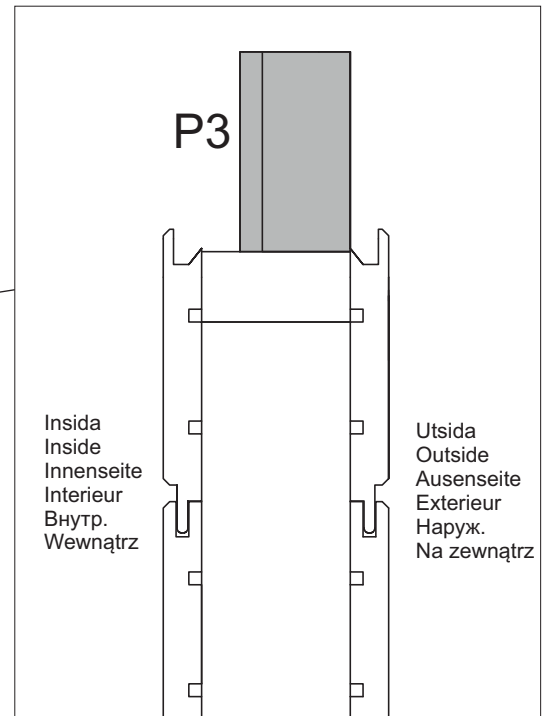
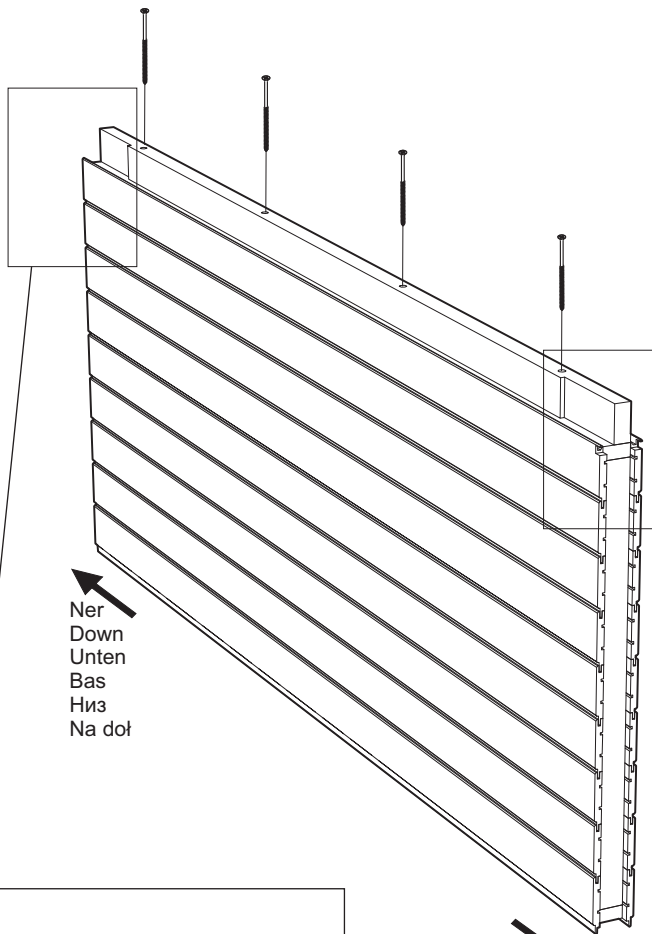
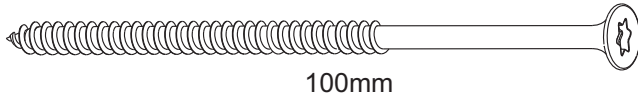
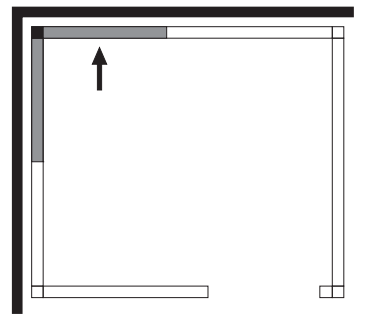
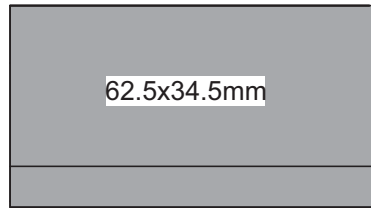

5 (Montering från insidan)
(Mounting from the inside)

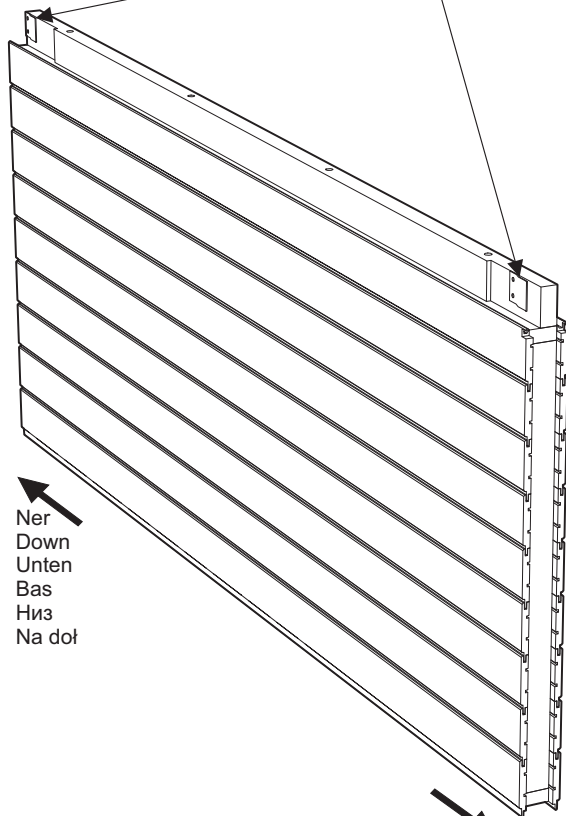
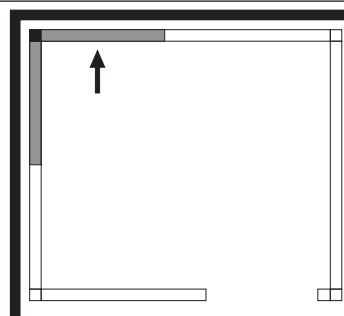
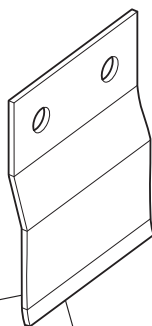
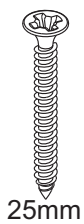
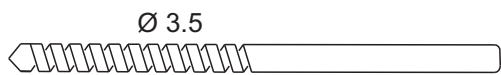

Ner
Down
Unten
Bas
Низ
Na doł

Upp
Up
Oben
Haut
Вверх
Do gory

Ner
Down
Unten
Bas
Низ
Na doł

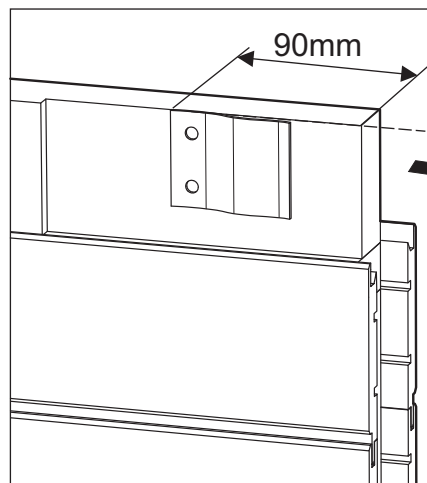
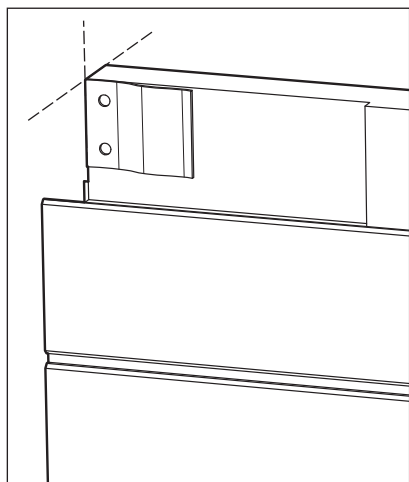

Upp
Up
Oben
Haut
Вверх
Do gory

6 (Montering från insidan)
(Mounting from the inside)

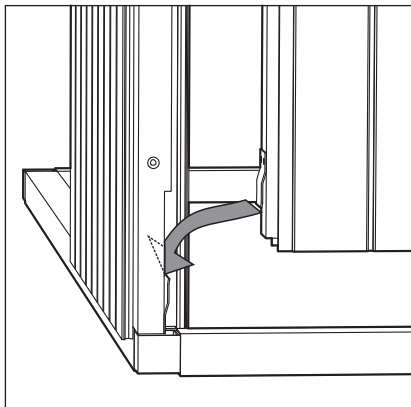
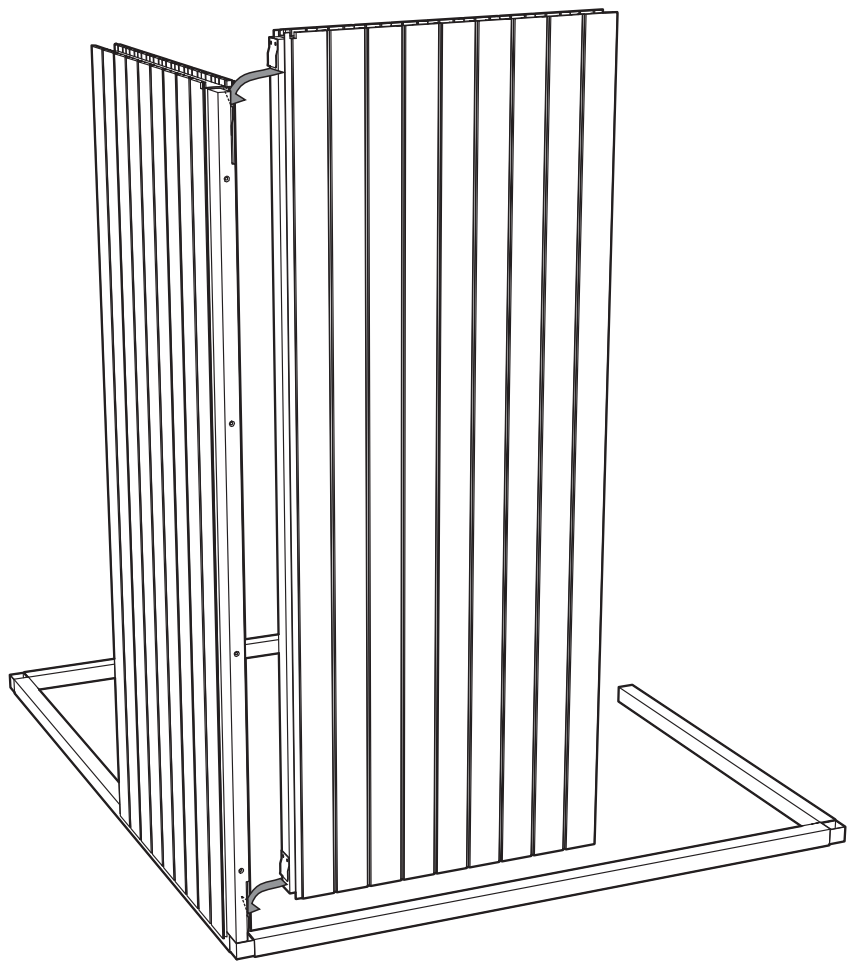
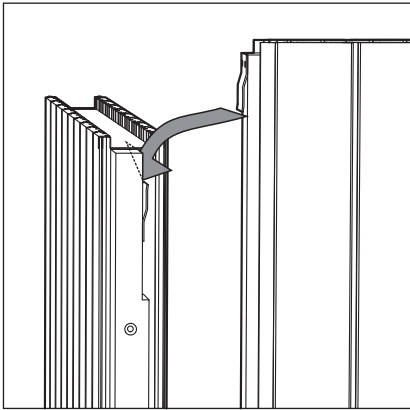
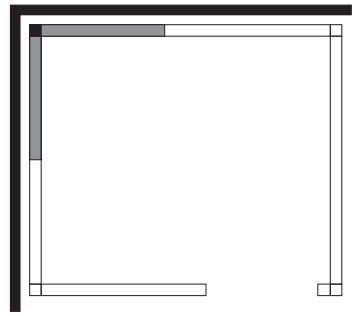

7 (Montering från insidan)
(Mounting from the inside)

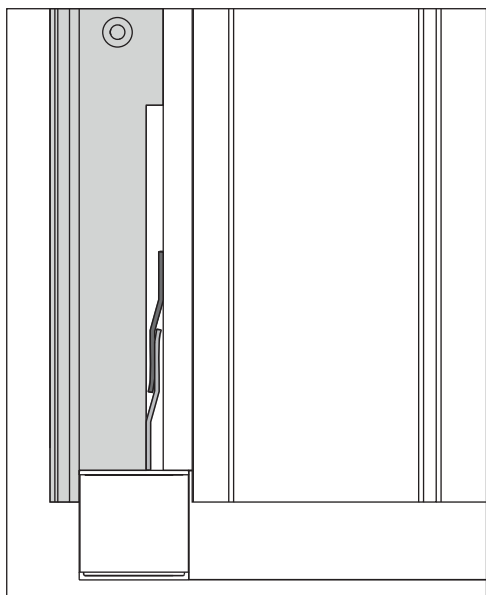
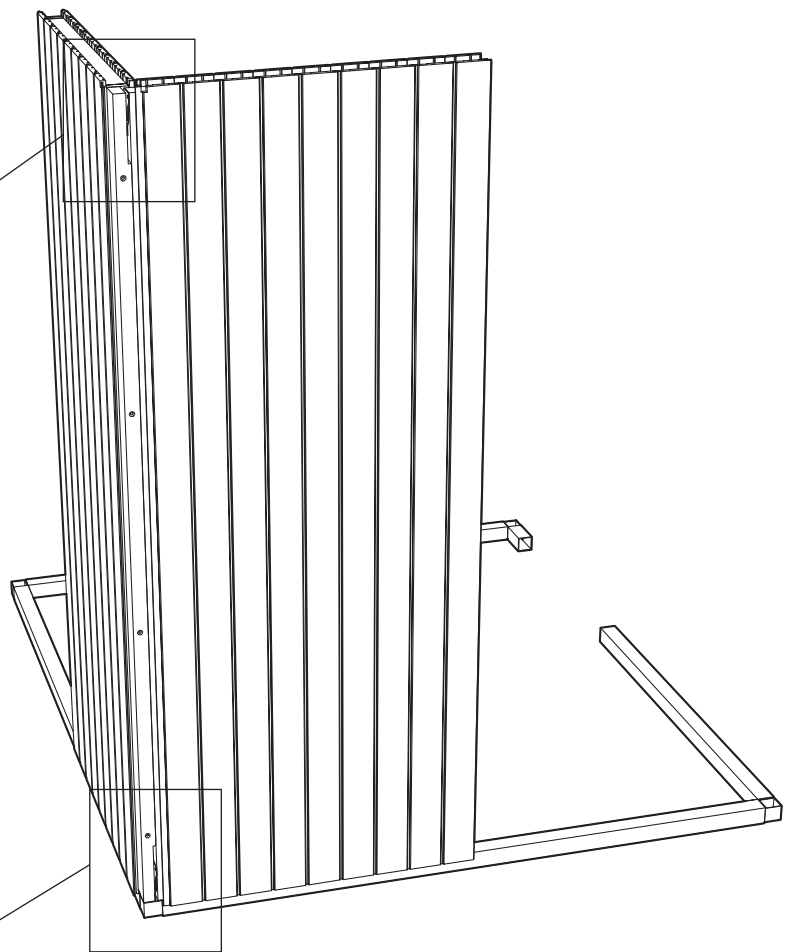
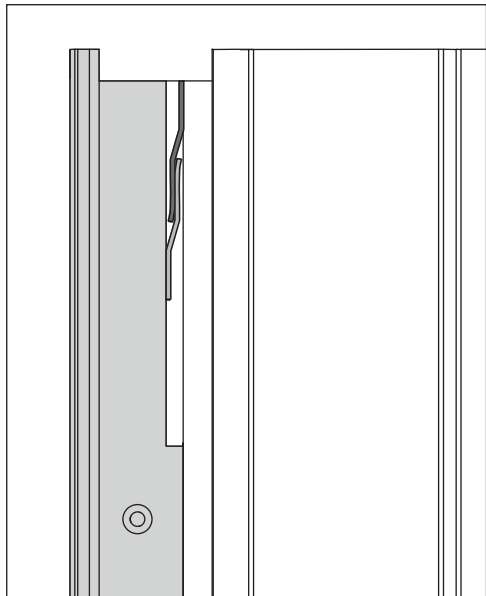
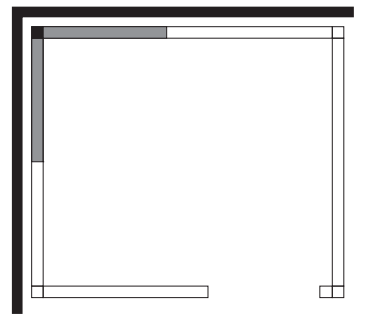
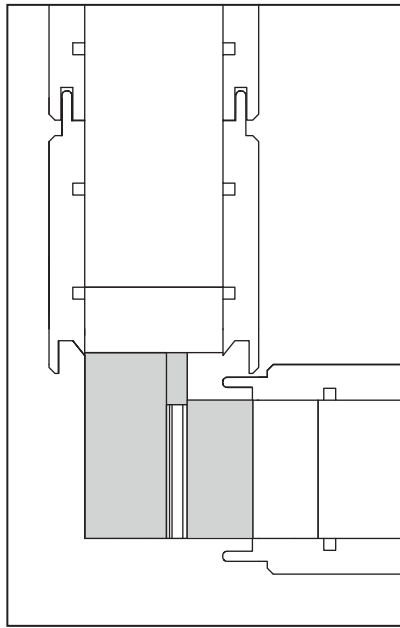

8

Resten av anvisningen visar hörnstolpar med skruvmontering av hörnen från utsidan.
Skall rummet monteras inifrån, se bild 2-7 vid ihopsättning av hörnstolpar med väggar.

The rest of the manual shows the corner posts mounted with screws from the outside.

Shall the room be mounted from the inside, see Figure 2-7 when the corner posts are mounted with the walls.

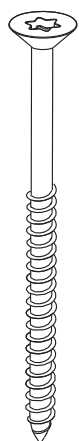
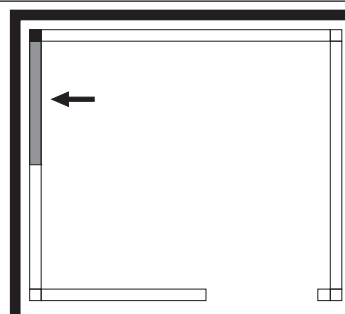

60mm

P2

47x22mm

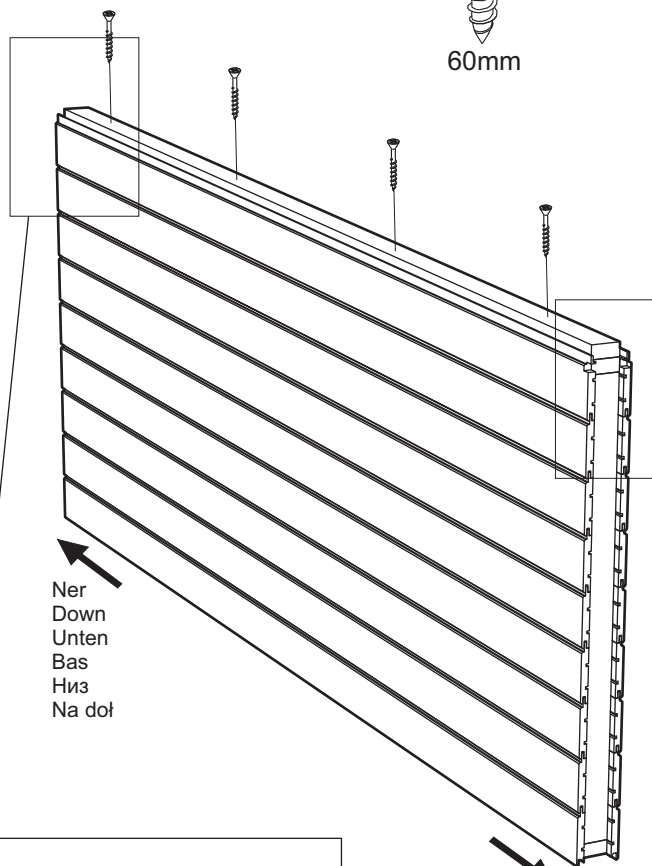
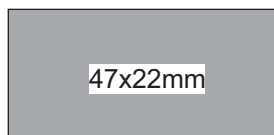

Ner
Down
Unten
Bas
Низ
Na doł

Upp
Up
Oben
Haut
Вверх
Do góry

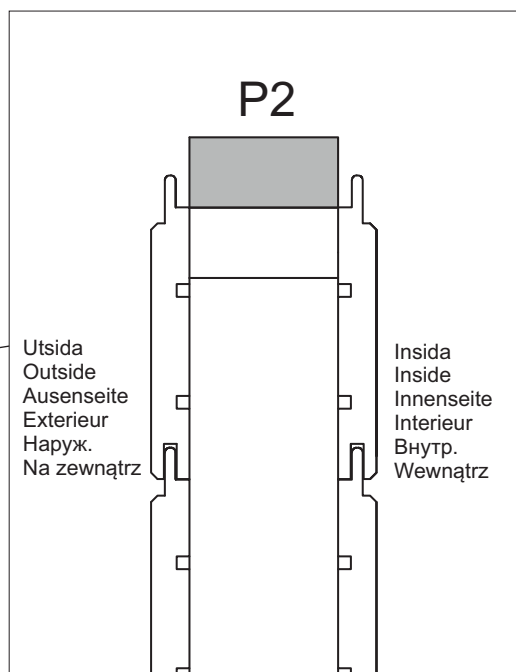

Utsida
Outside
Ausenseite
Exterieur
Навуж.
Na zewnątrz

Insida
Inside
Innenseite
Interieur
Внутр.
Wewnątrz

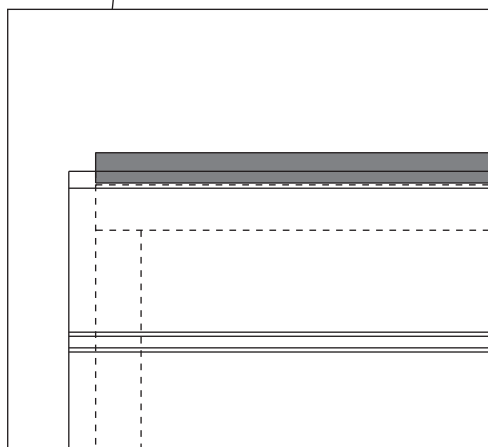

9

P3

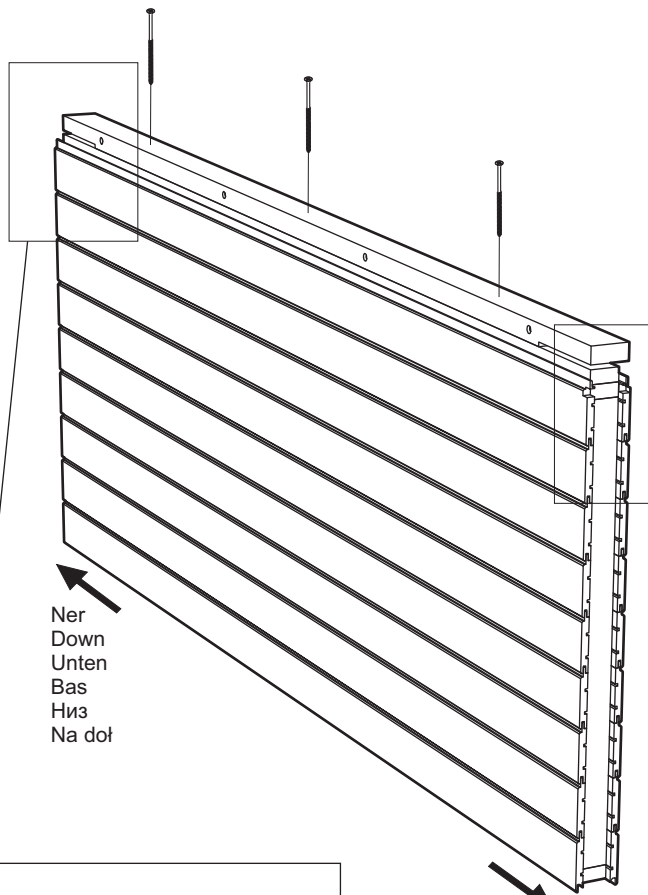
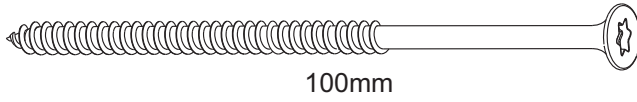
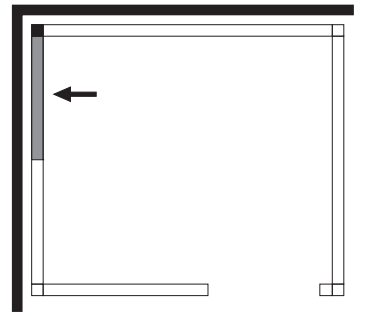
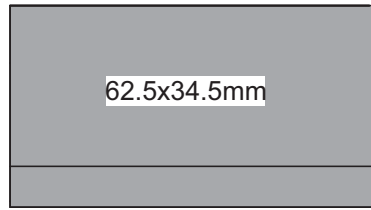

Ner
Down
Unten
Bas
Низ
Na doł

Upp
Up
Oben
Haut
Вверх
Do gory

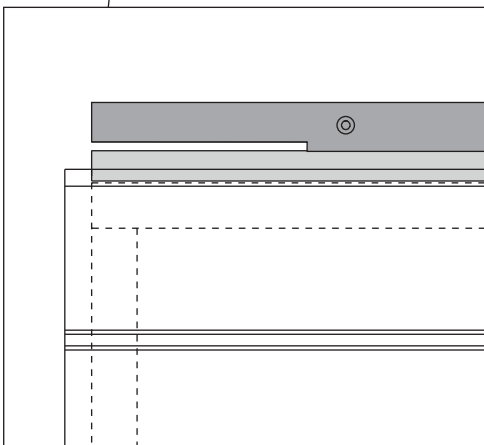
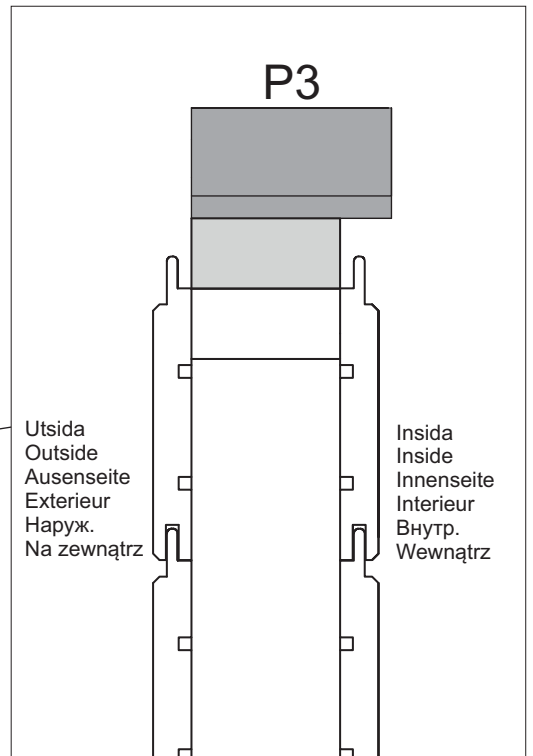

10

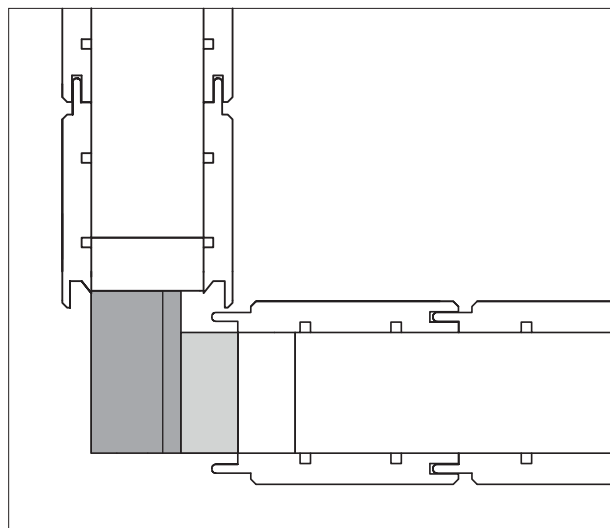
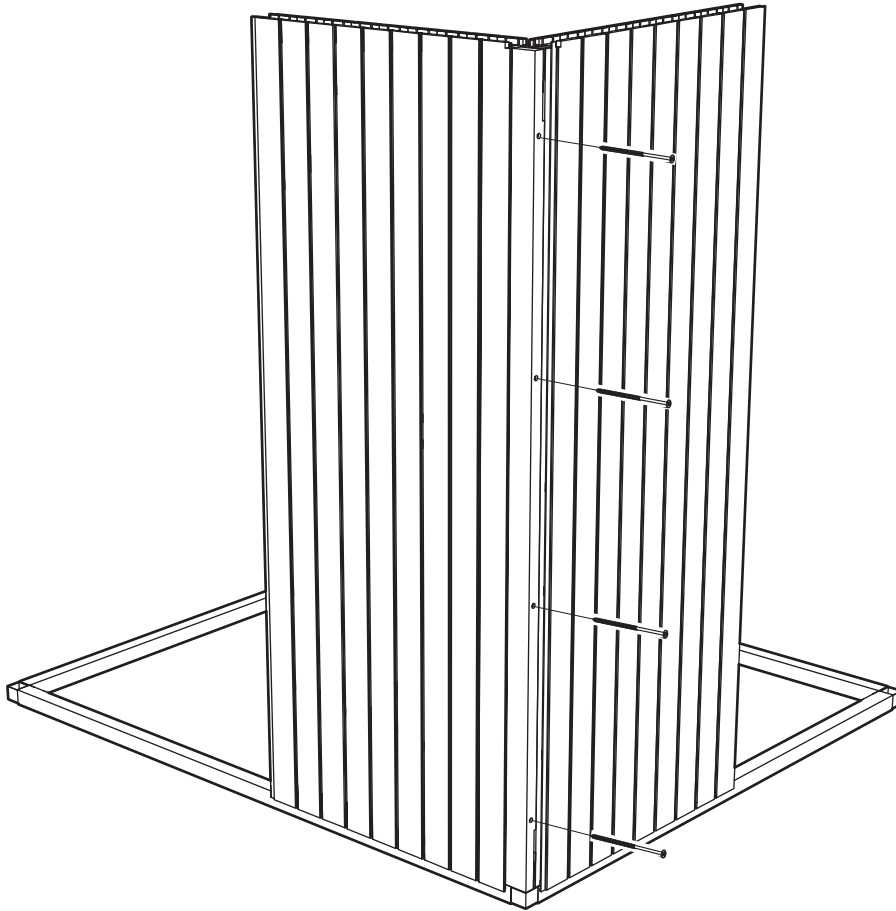
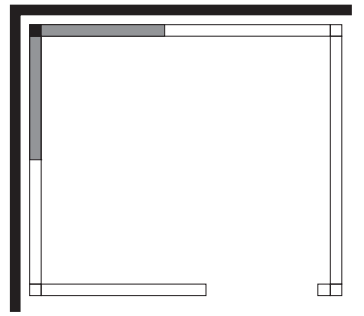
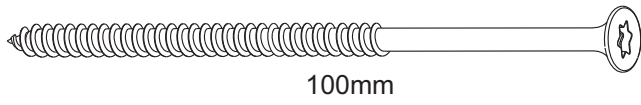

11

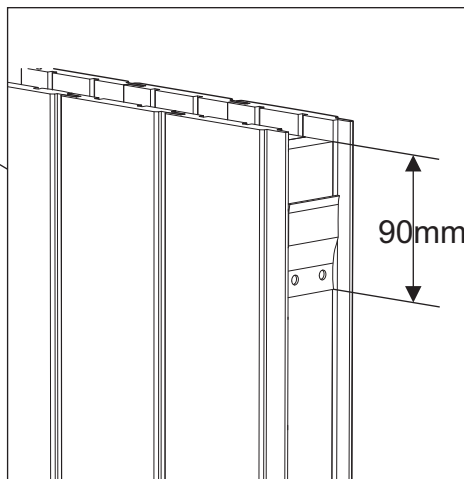
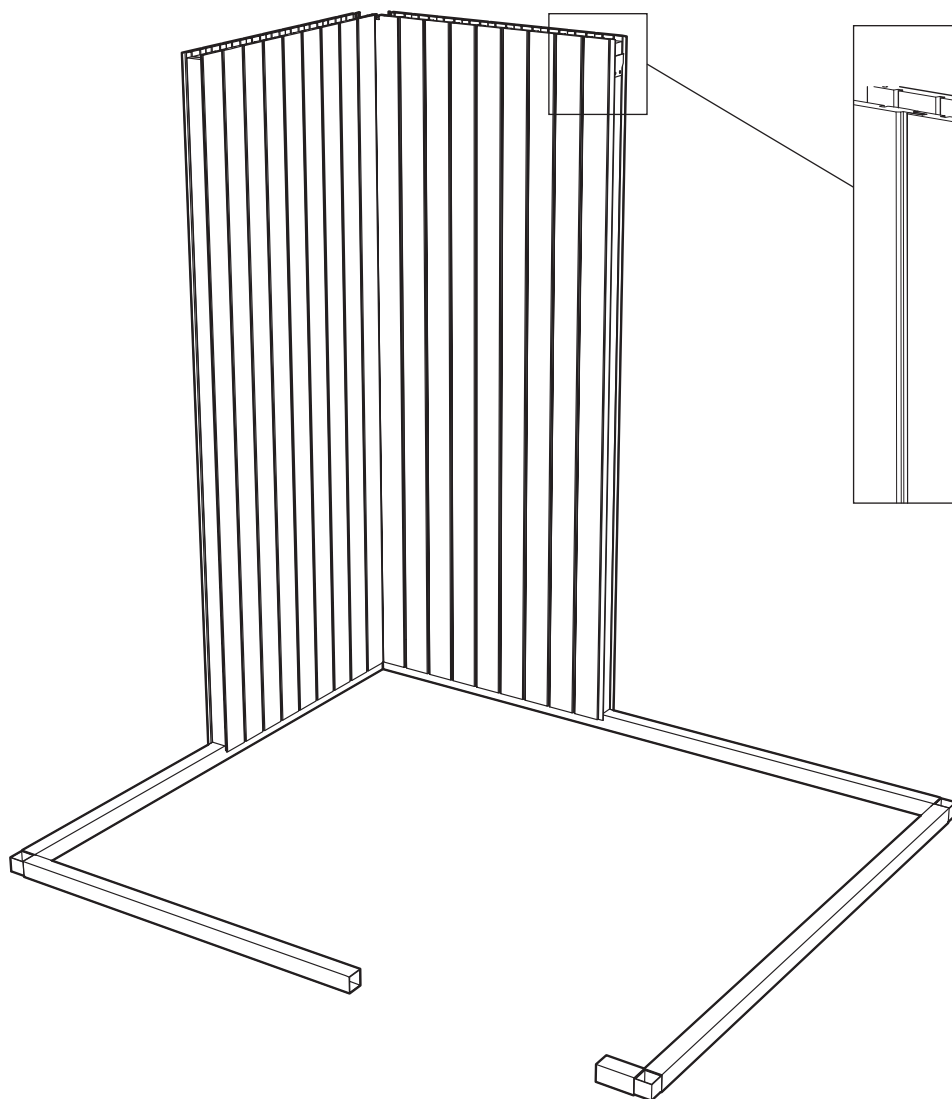
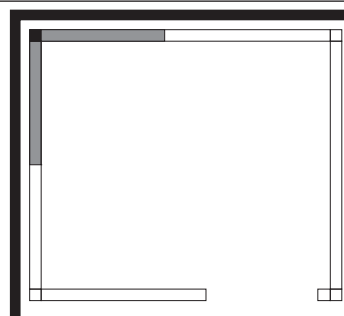
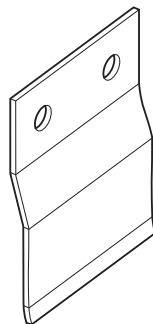
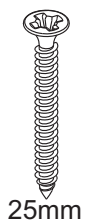
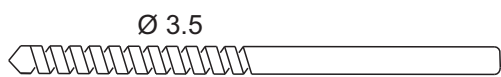

Använd medskickad mall
Use the enclosed template

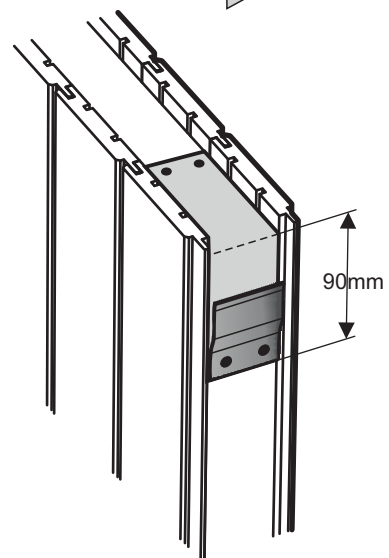
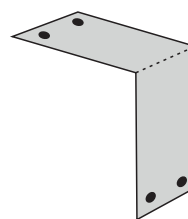

12

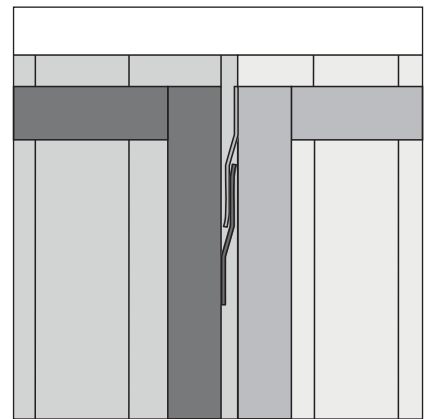
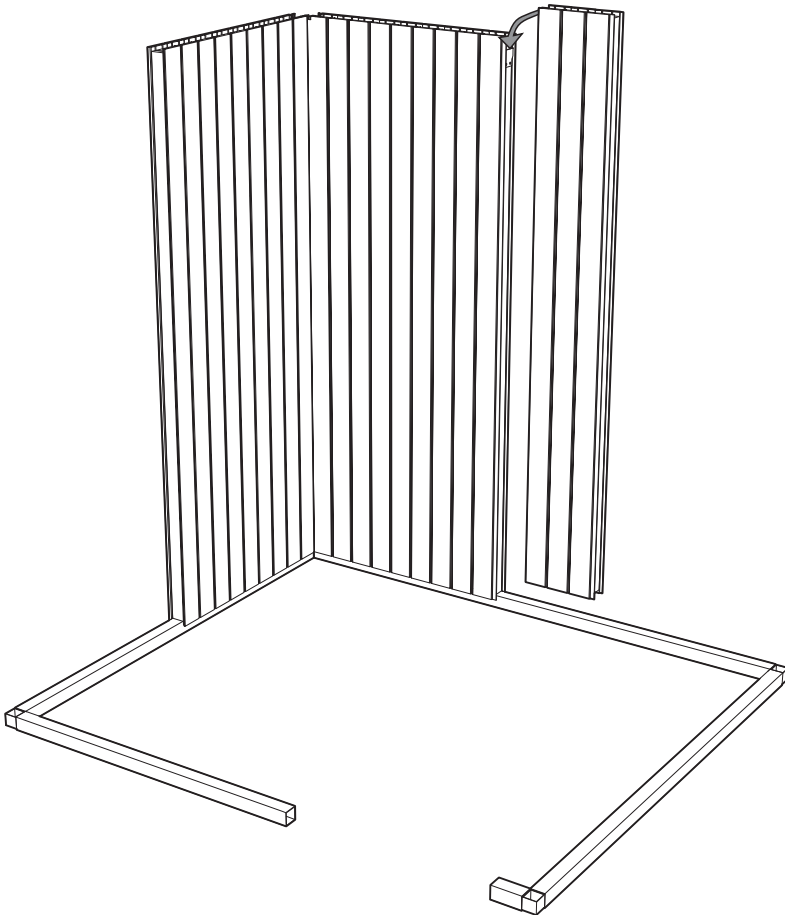
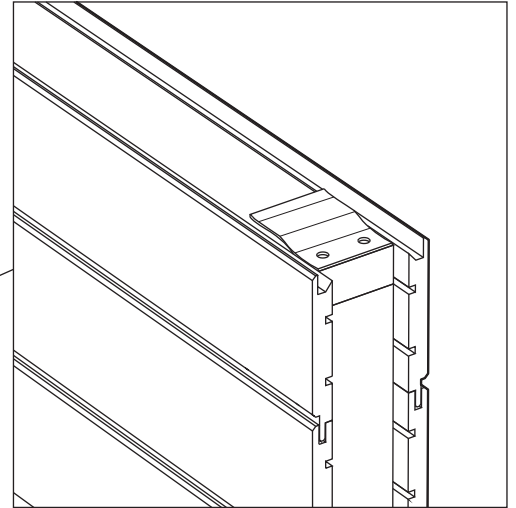
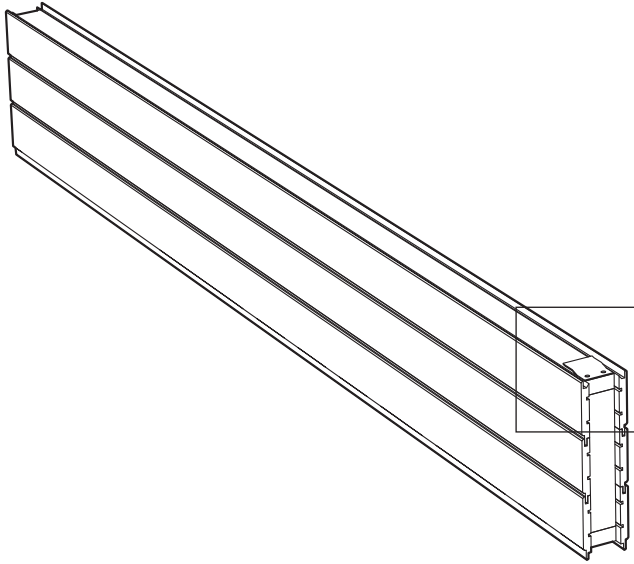
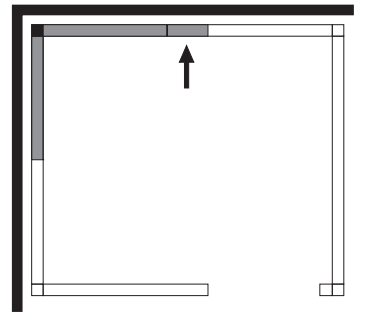
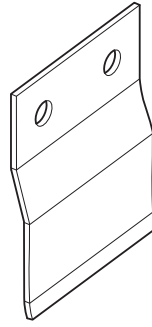
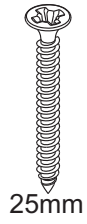
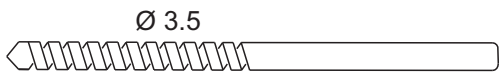

13

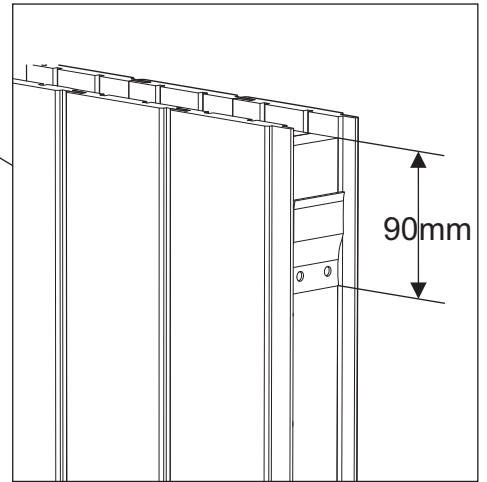
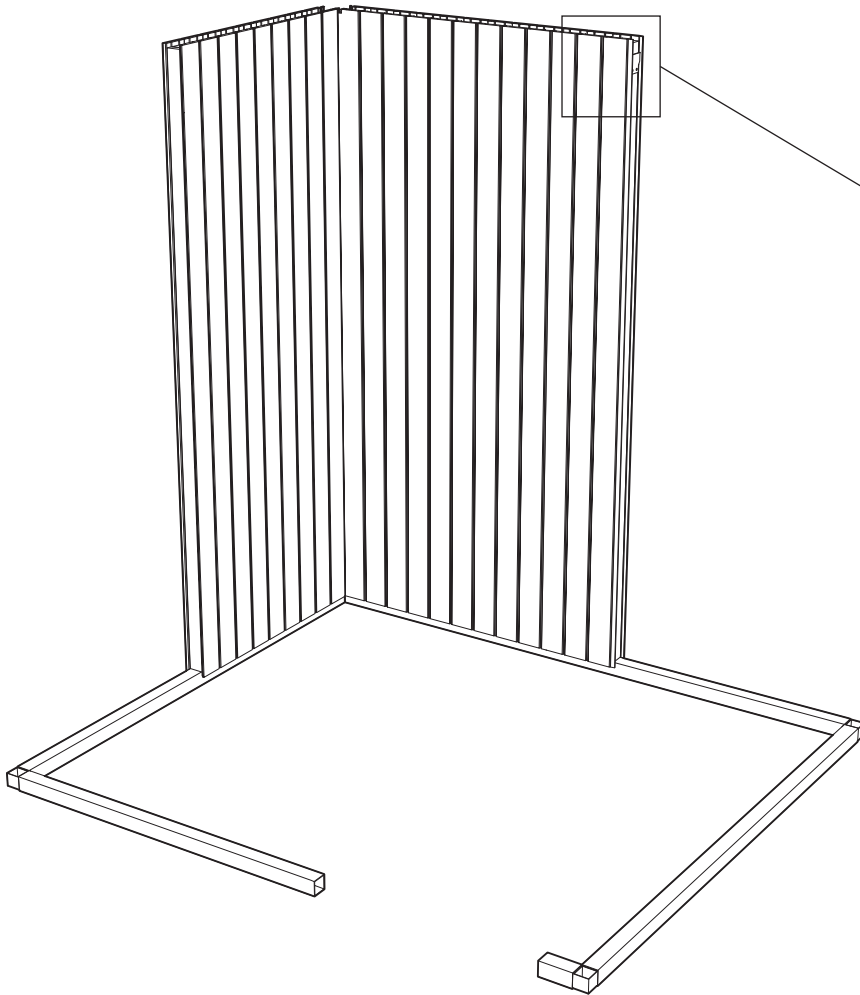
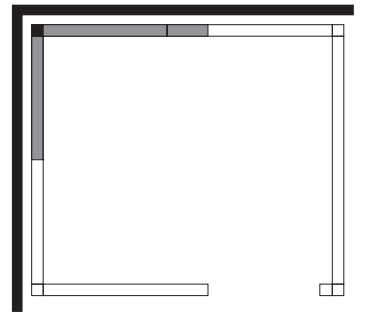
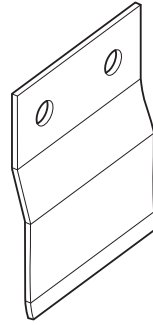
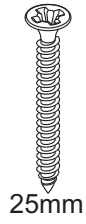
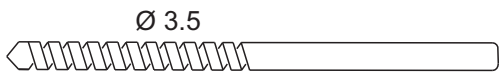

14

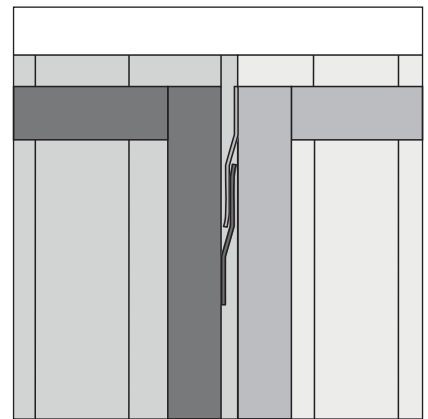
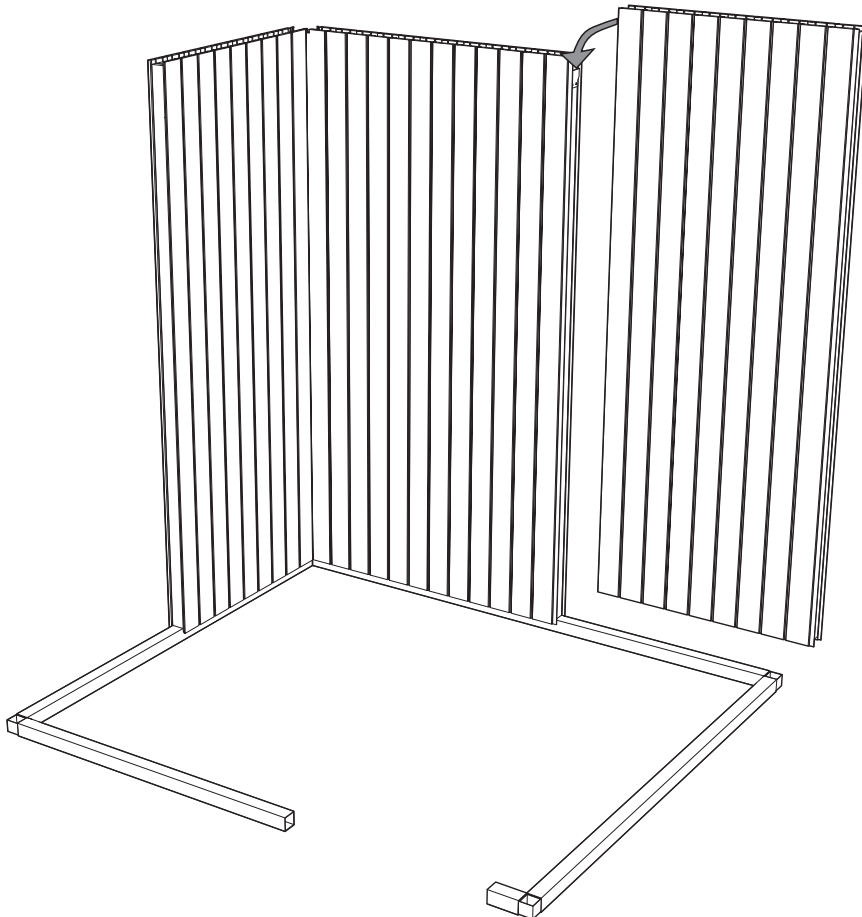
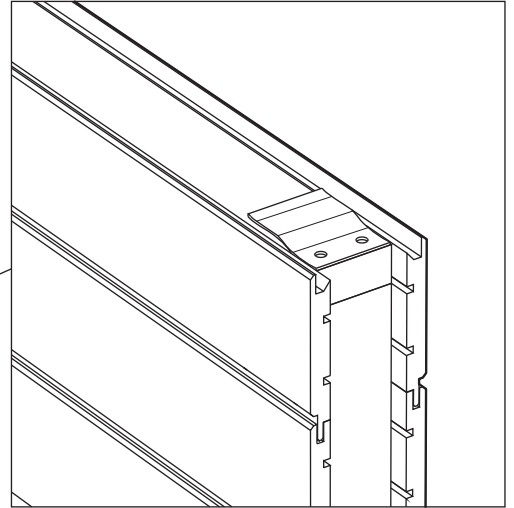
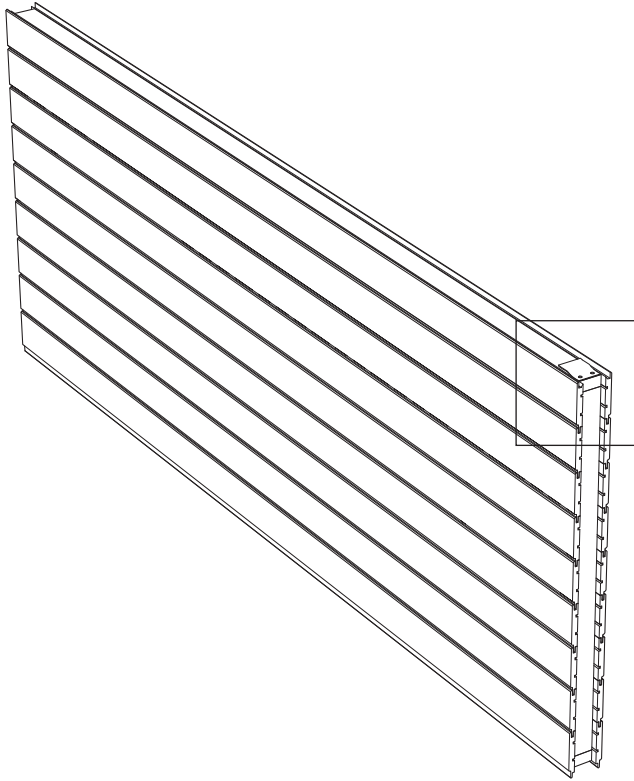
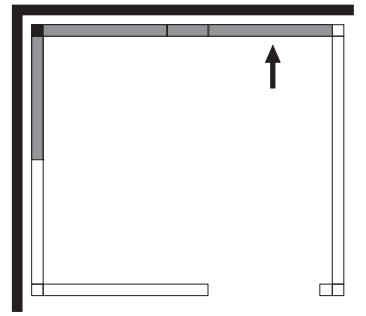
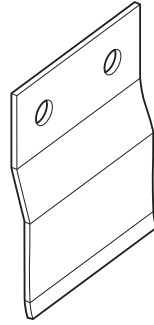
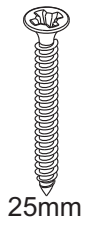
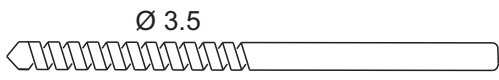

15

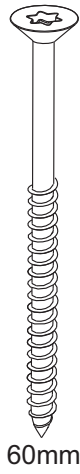

P2

47x22mm

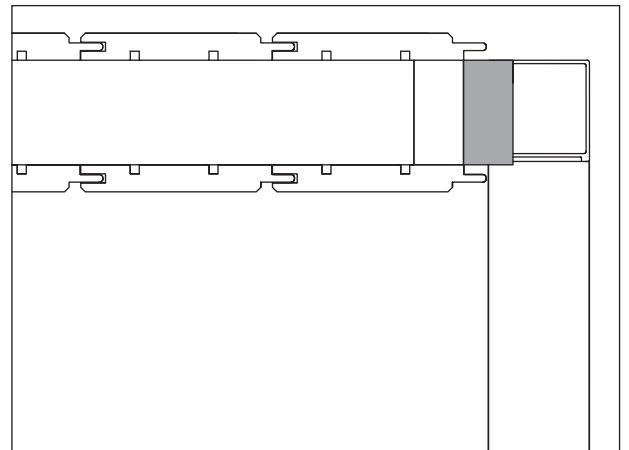
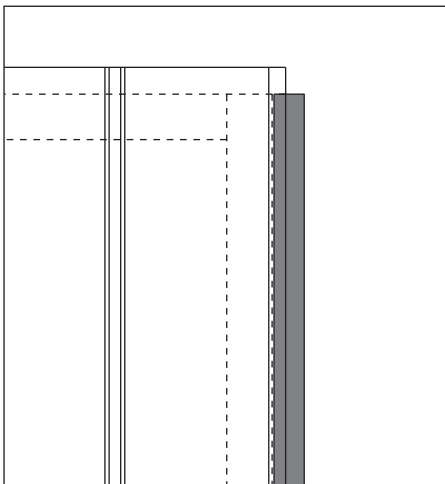
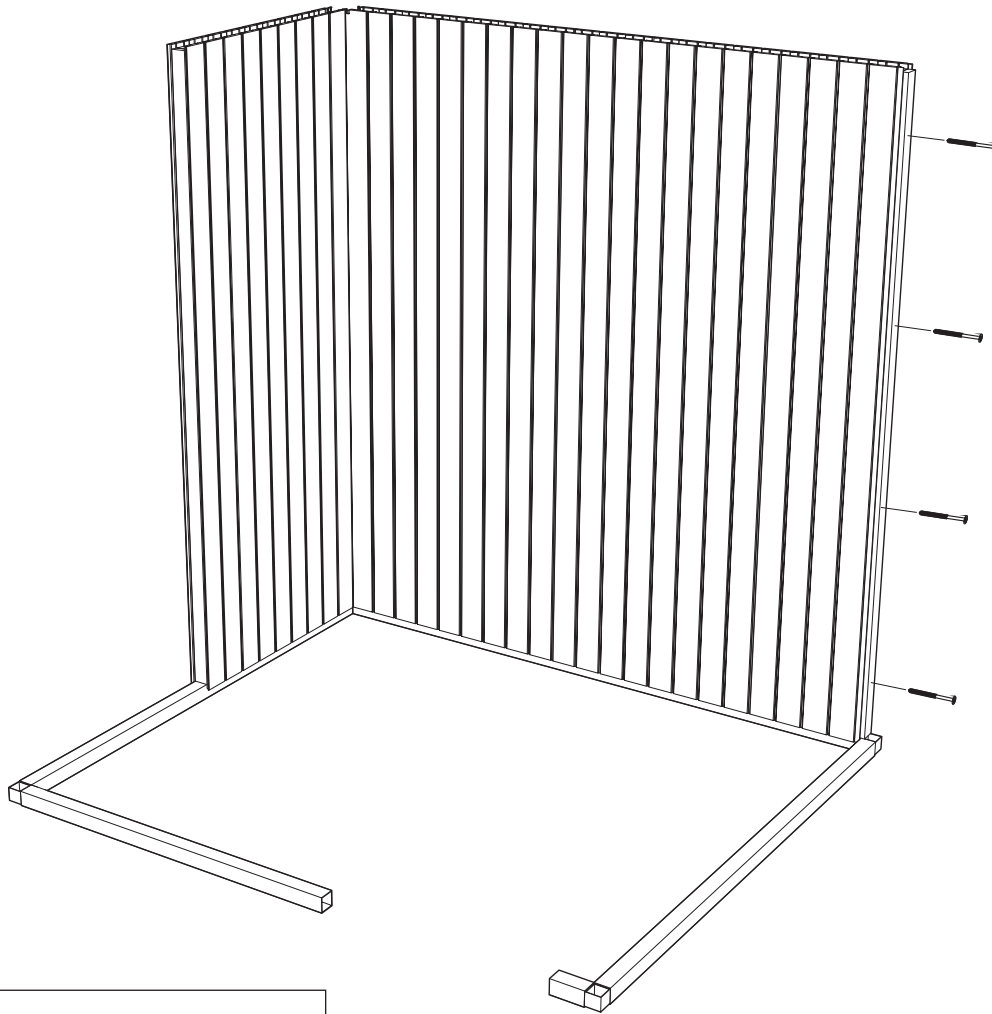
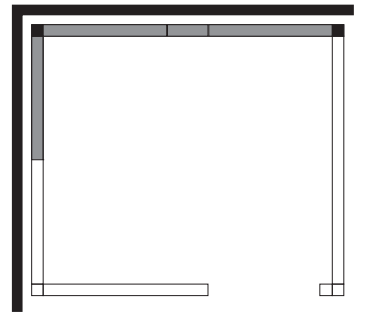

16

P3

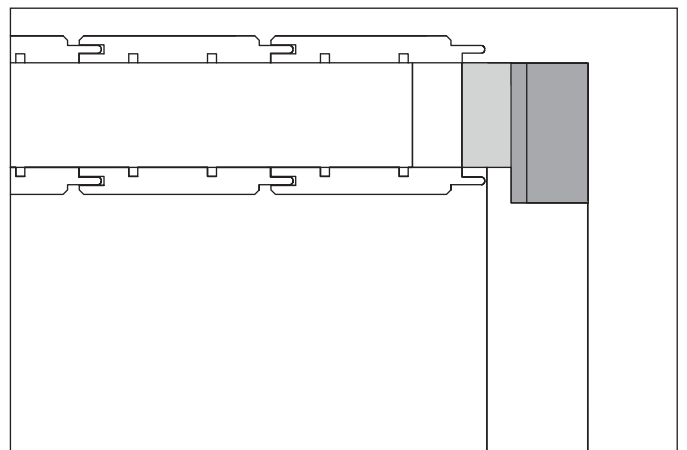
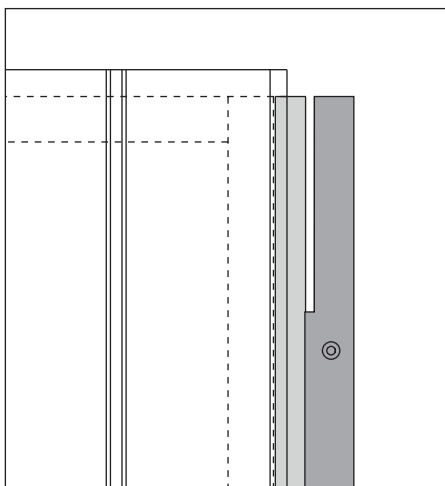
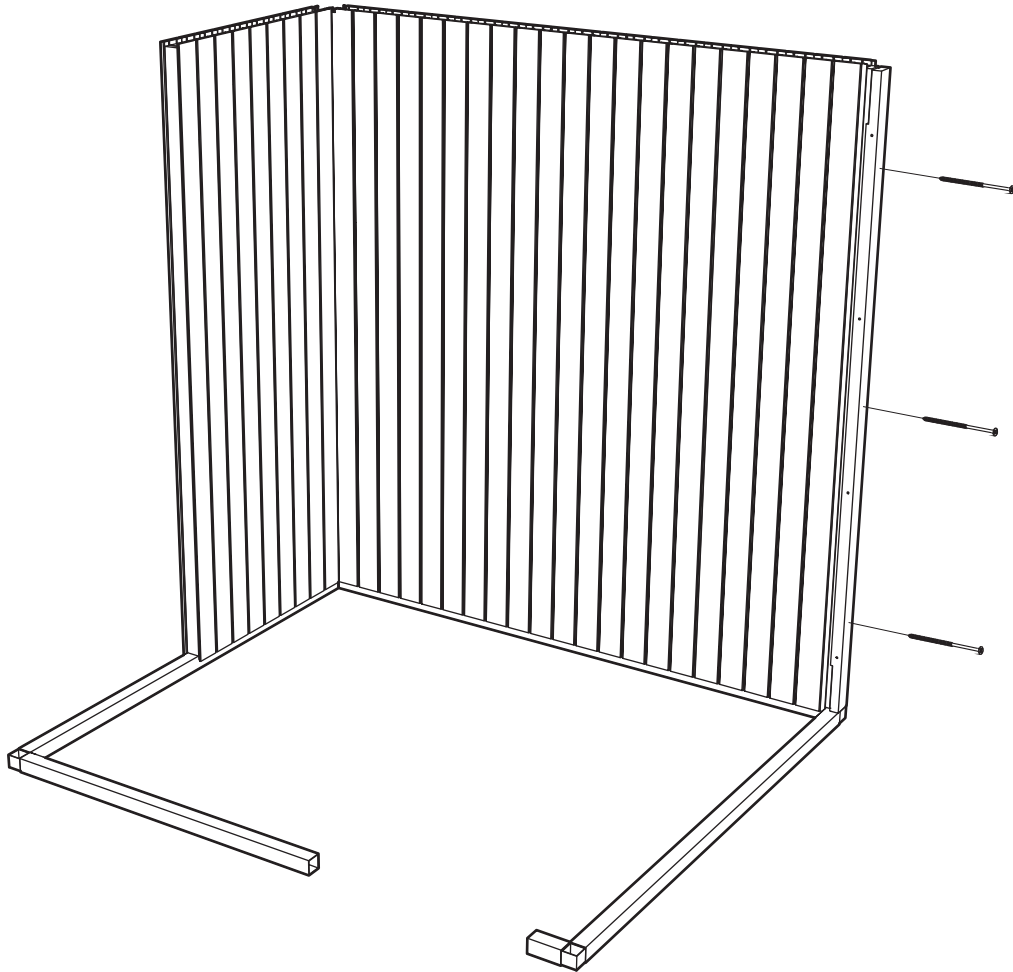
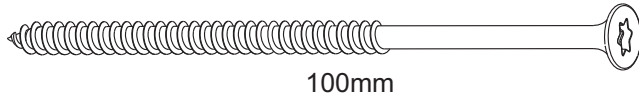
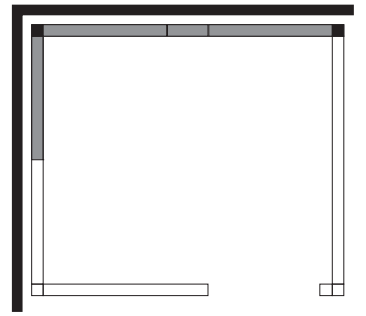
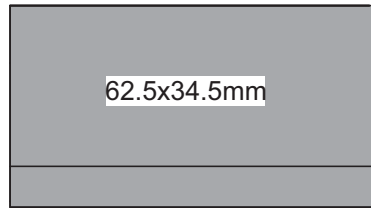

17

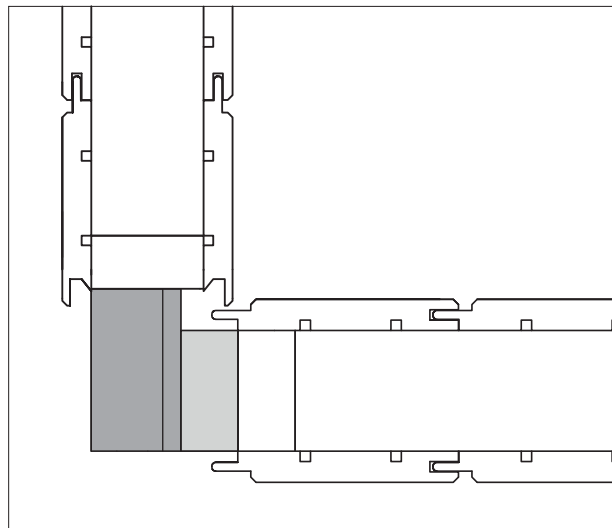
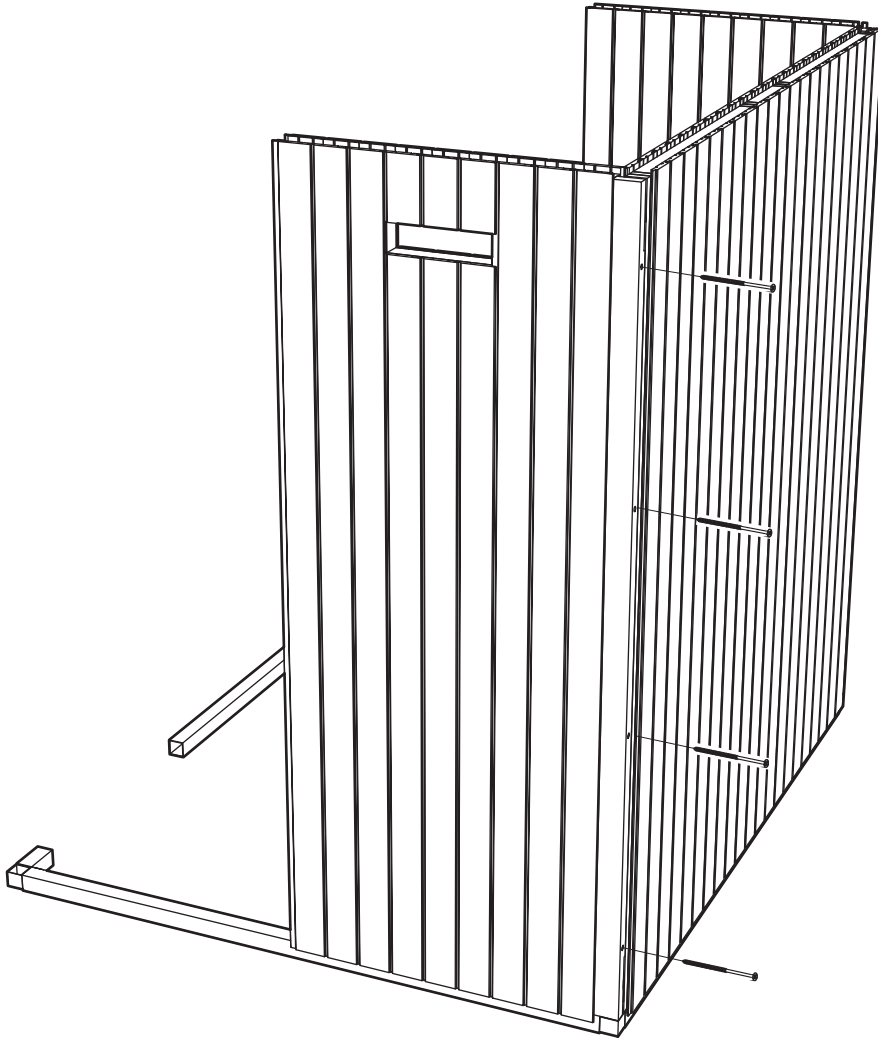
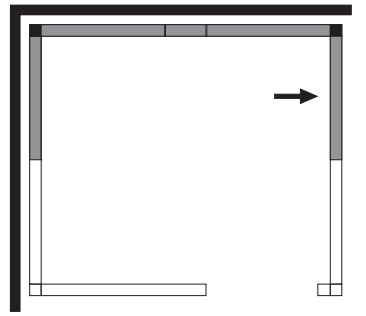
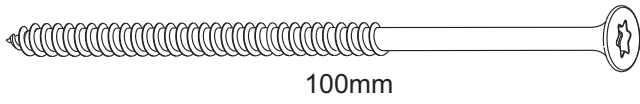

18

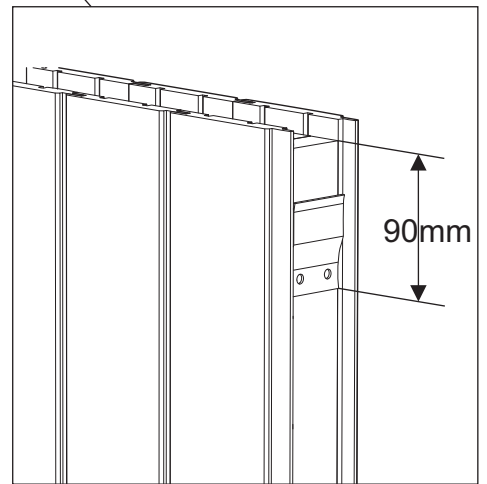
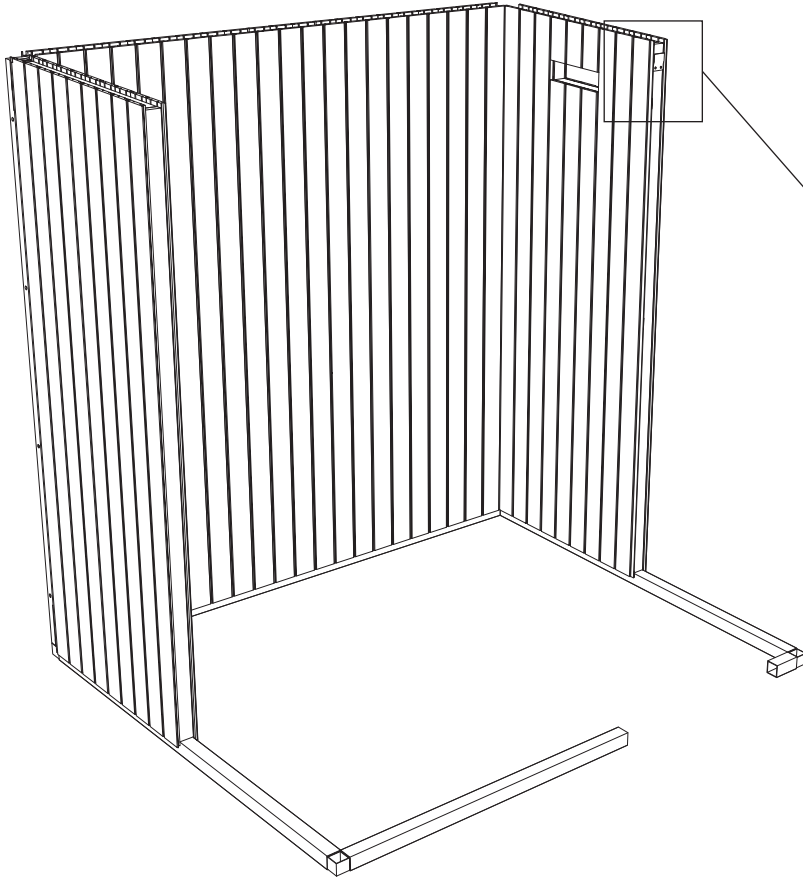
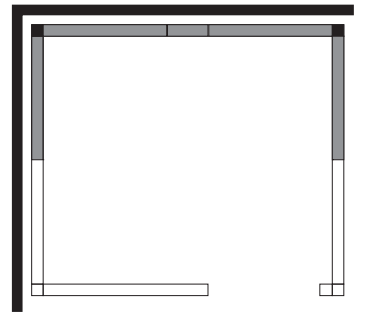
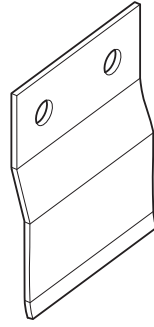
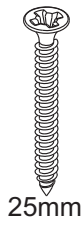
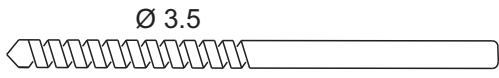

19

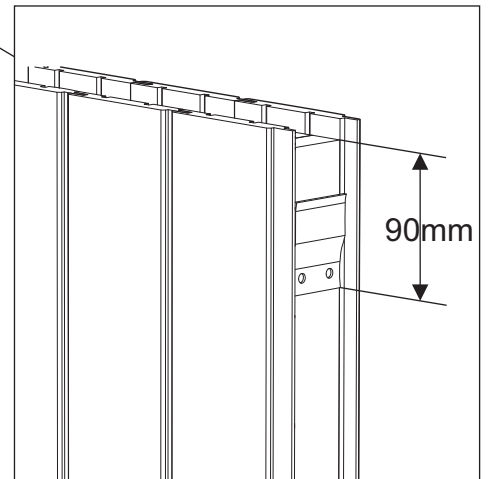
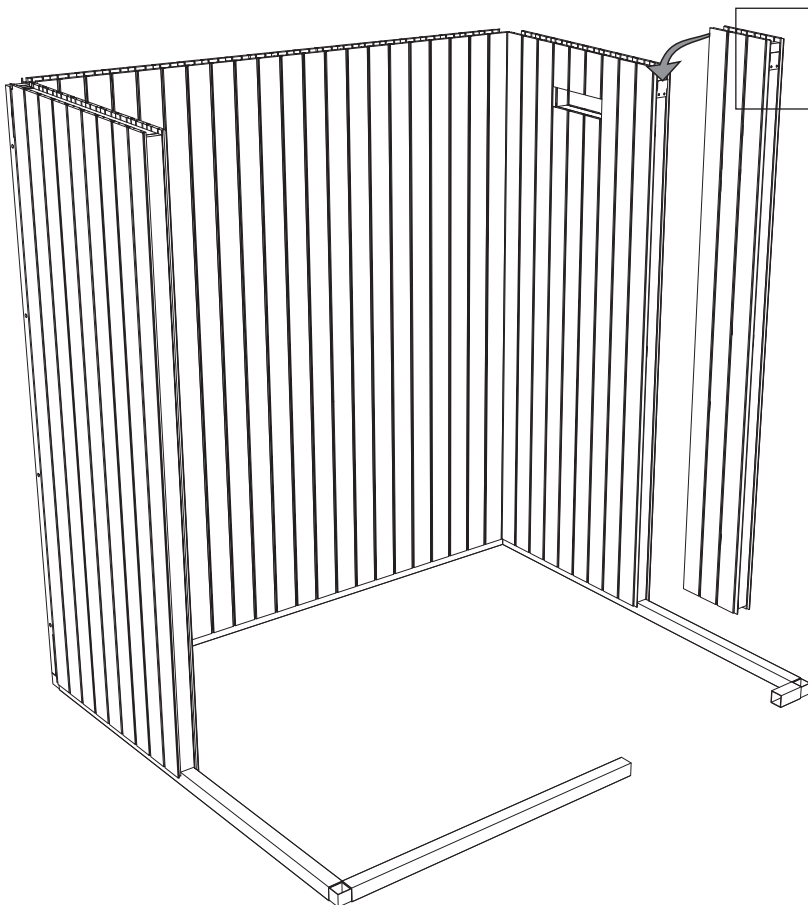
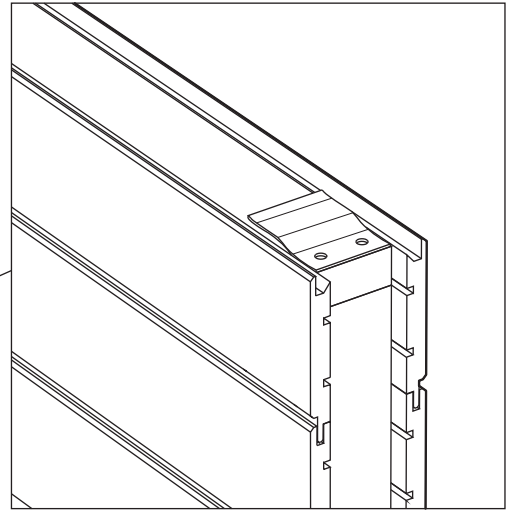
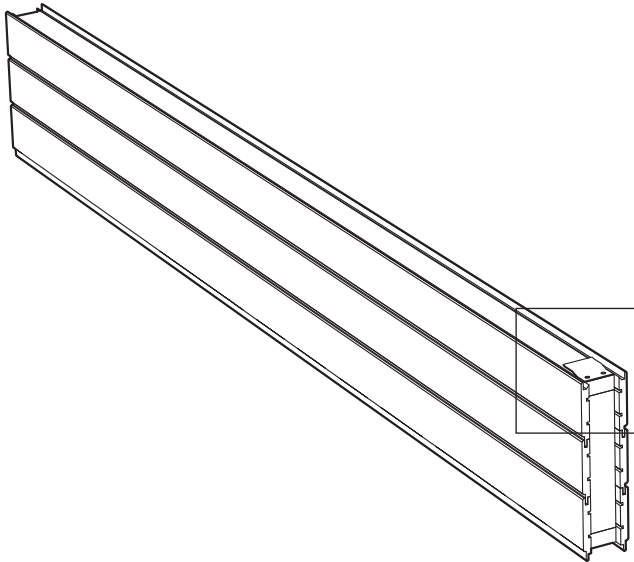
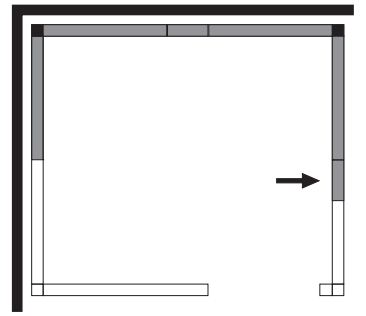
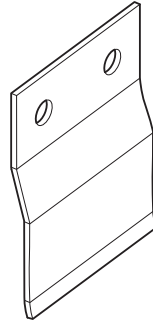
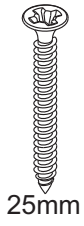
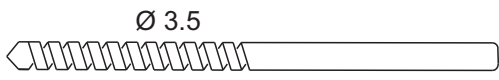

20

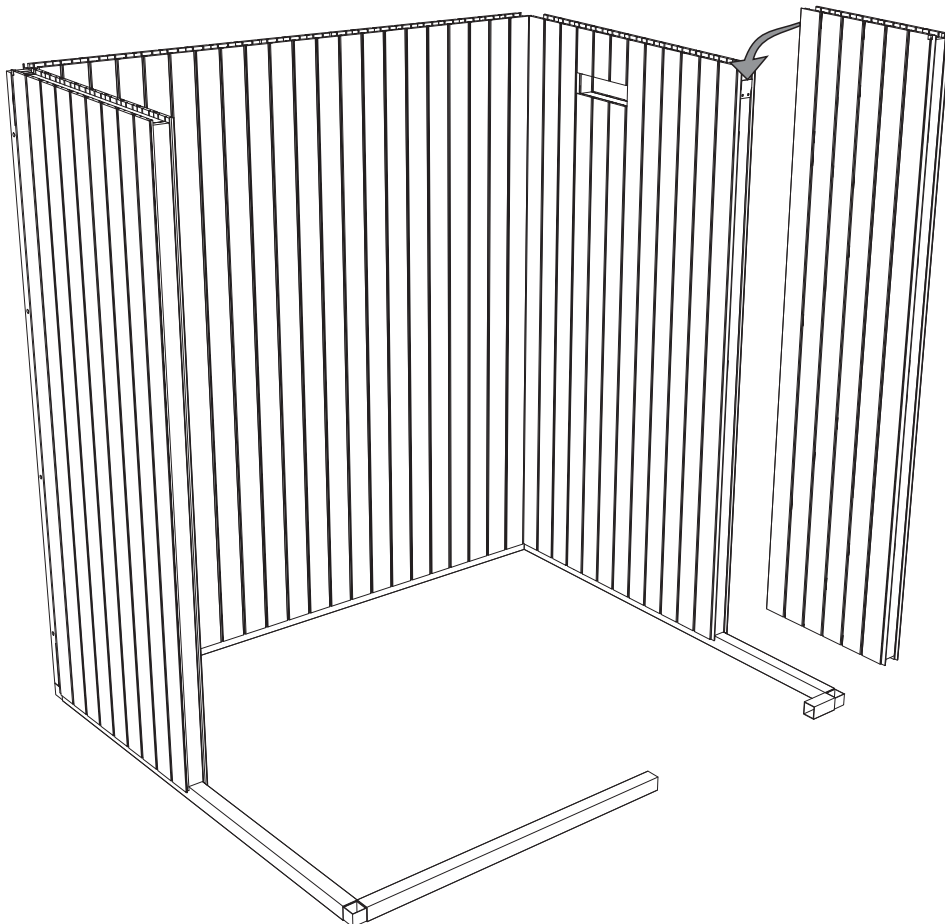
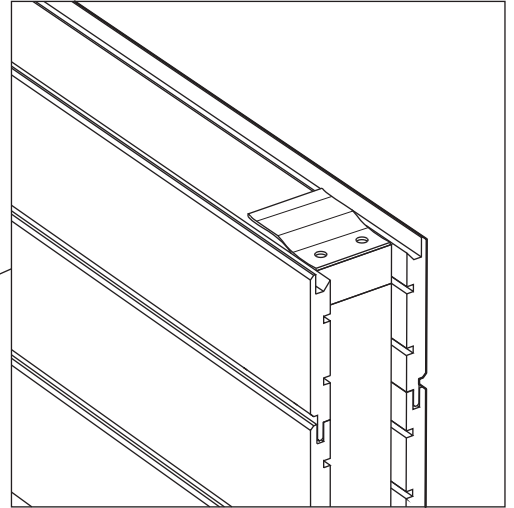
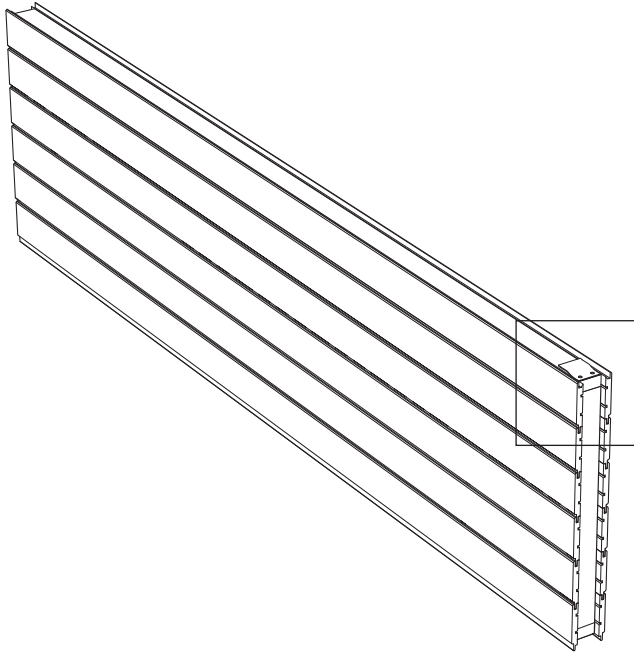
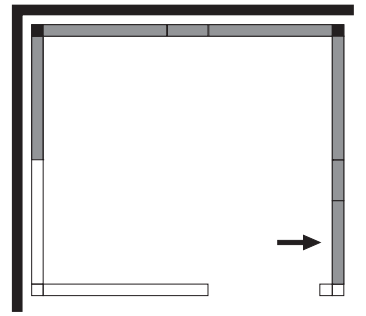
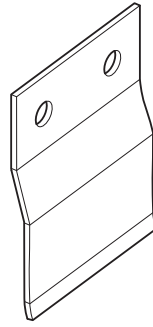
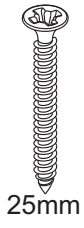
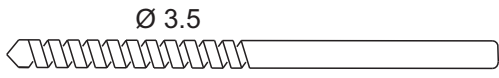

21

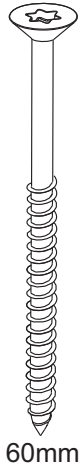

P2

47x22mm

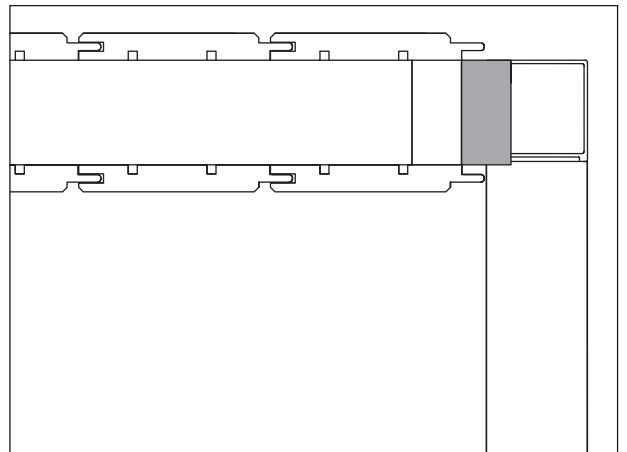
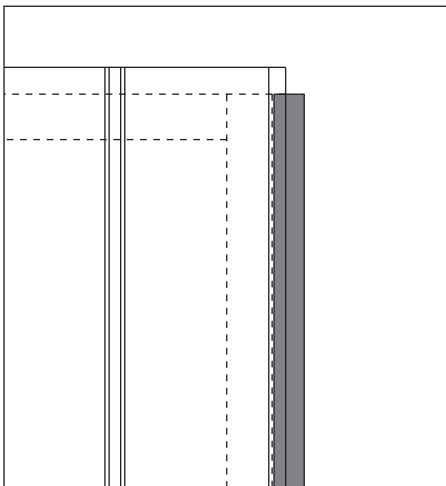
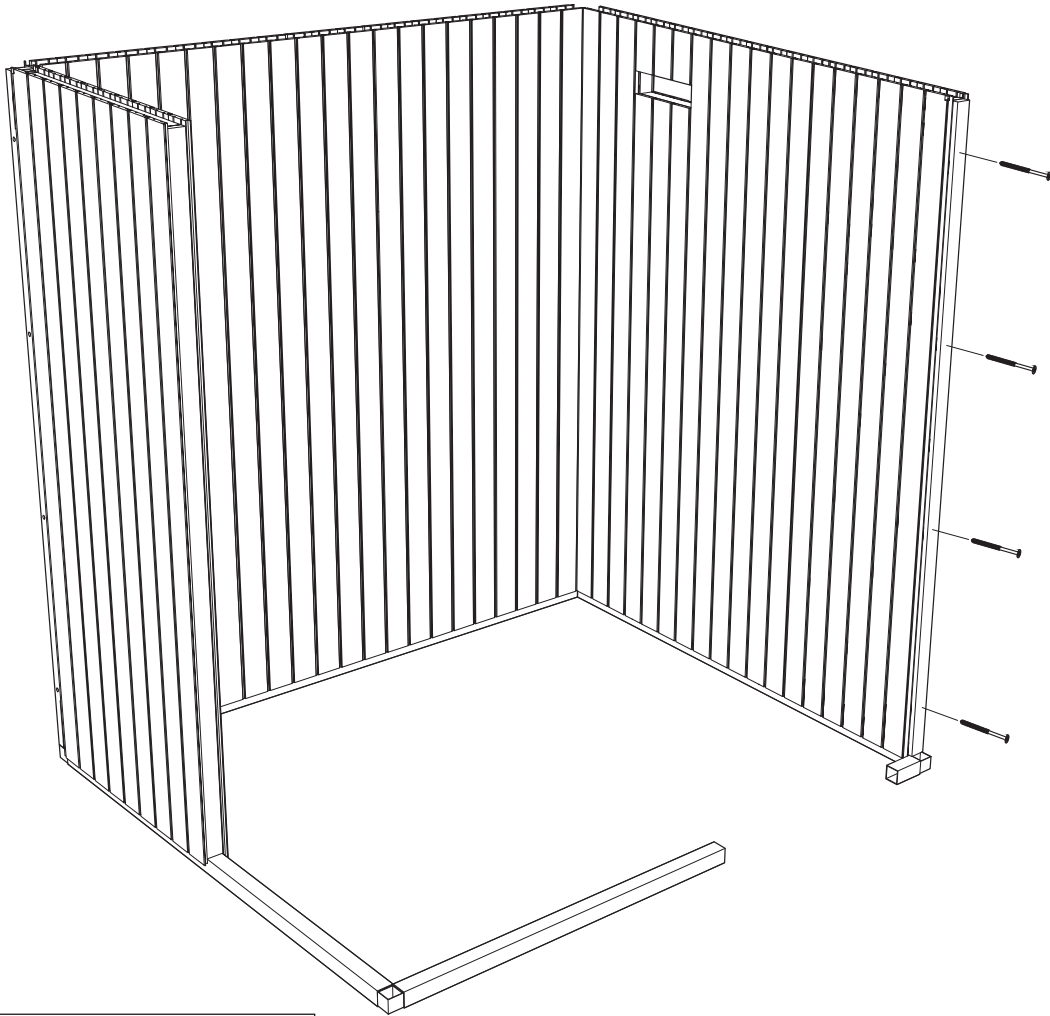
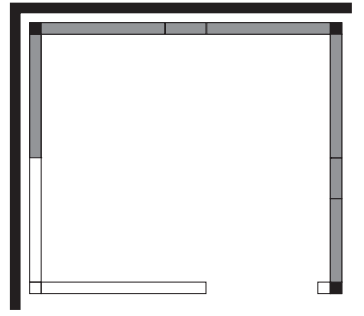
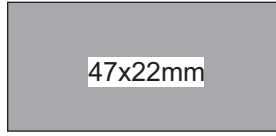

22

P3

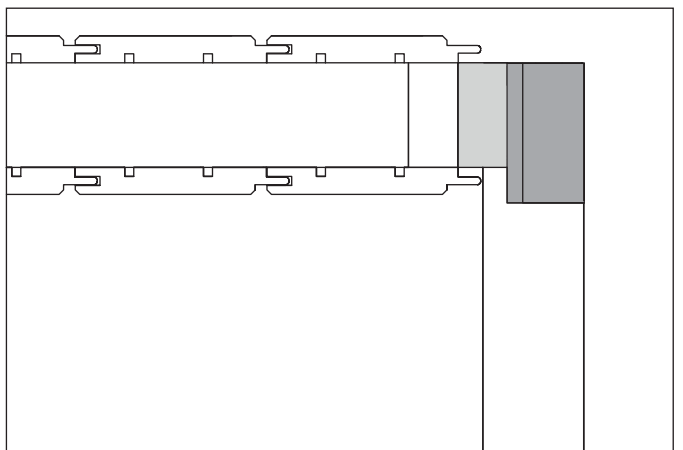
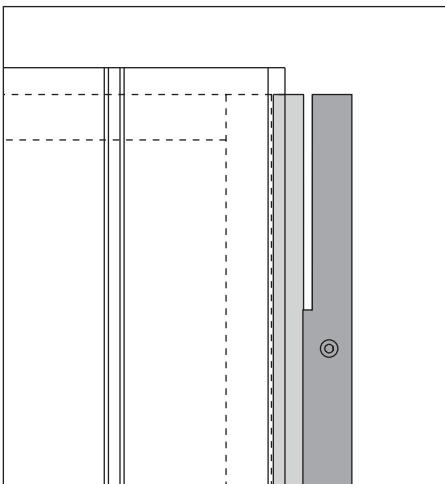
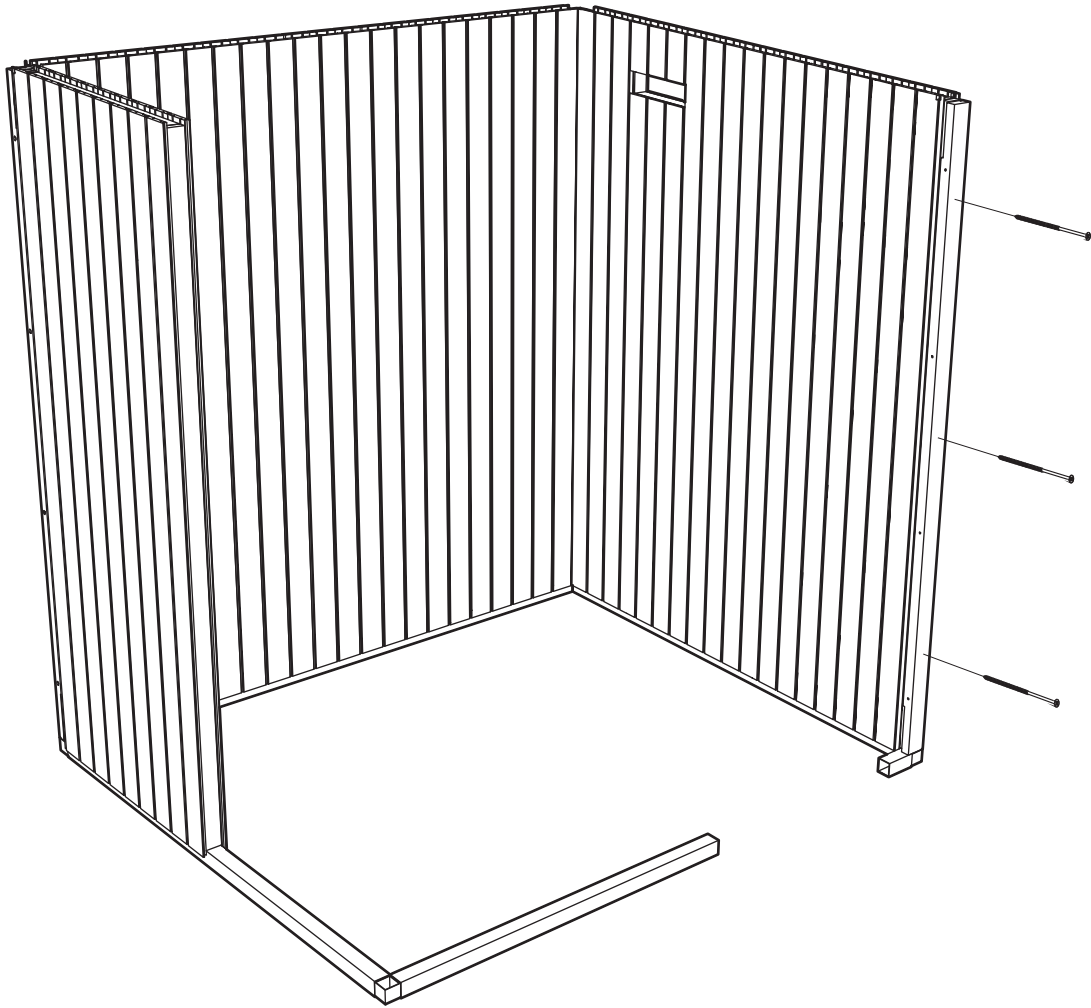
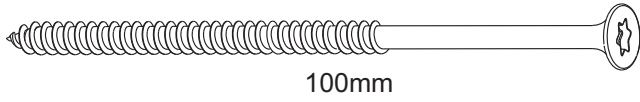
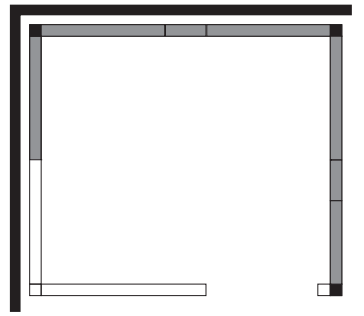
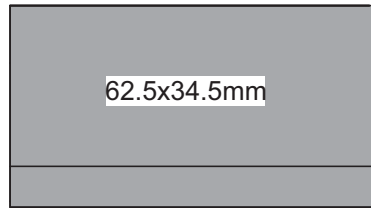

23

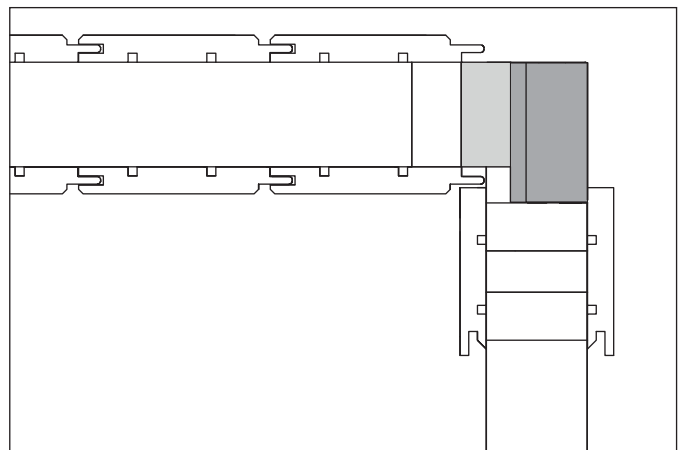
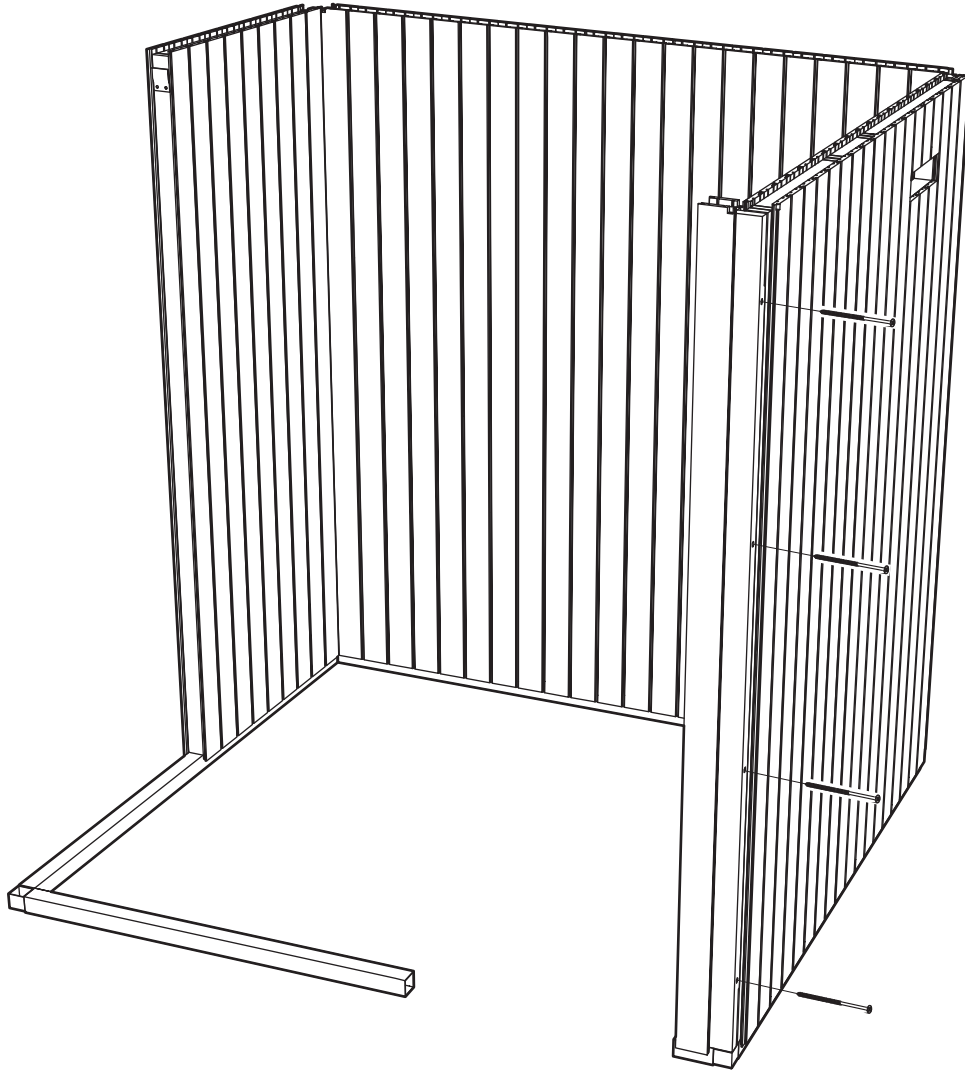
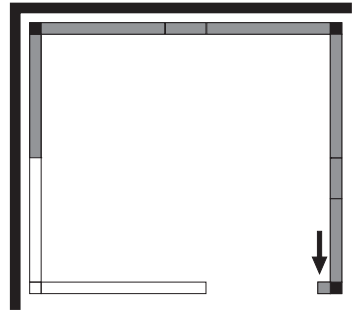
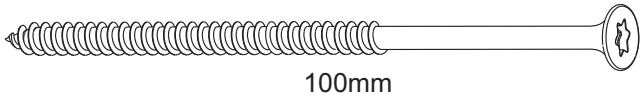

24

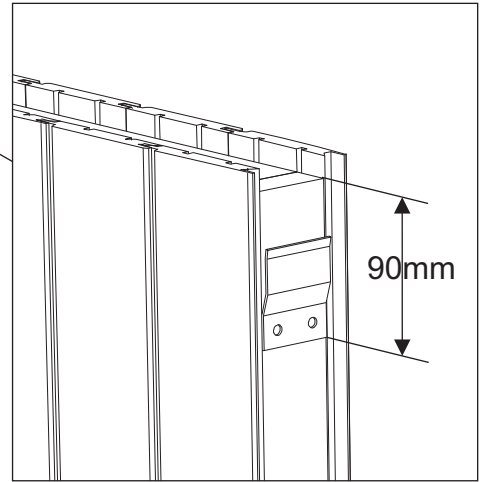
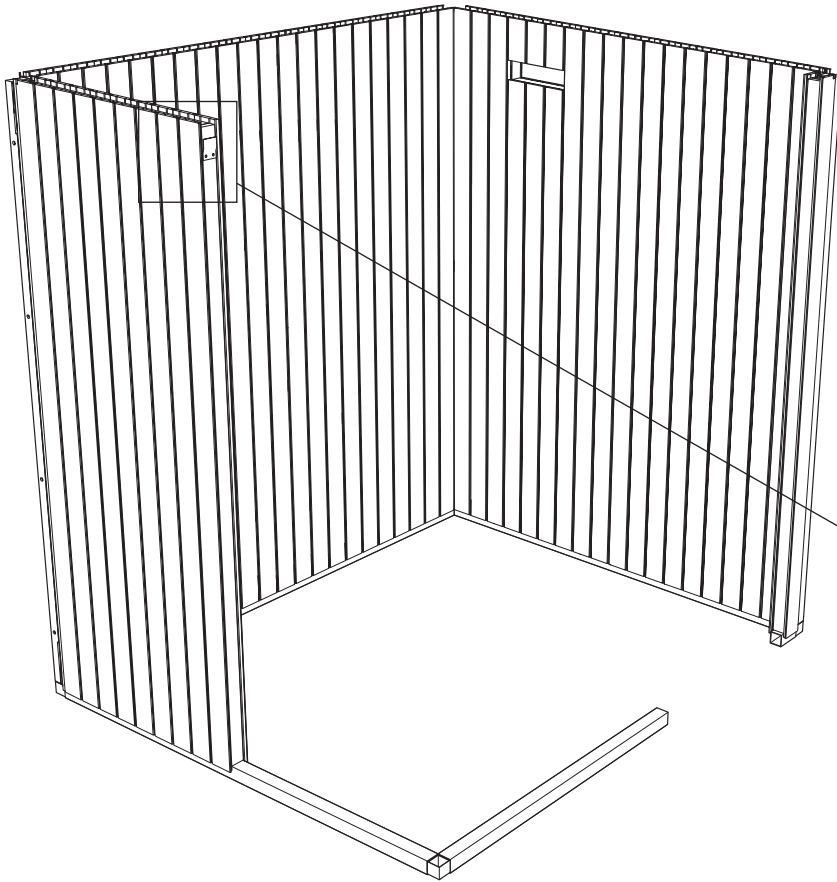
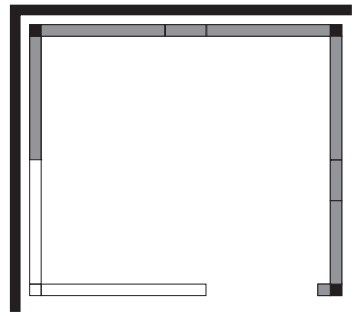
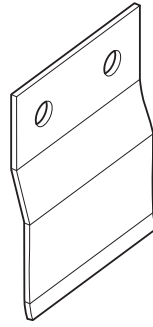
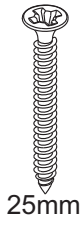
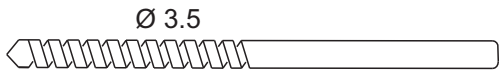

25

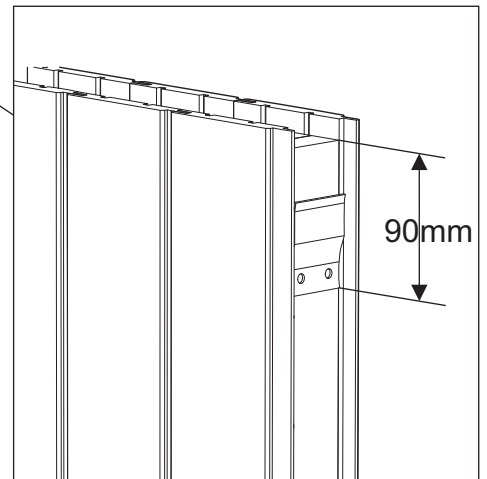
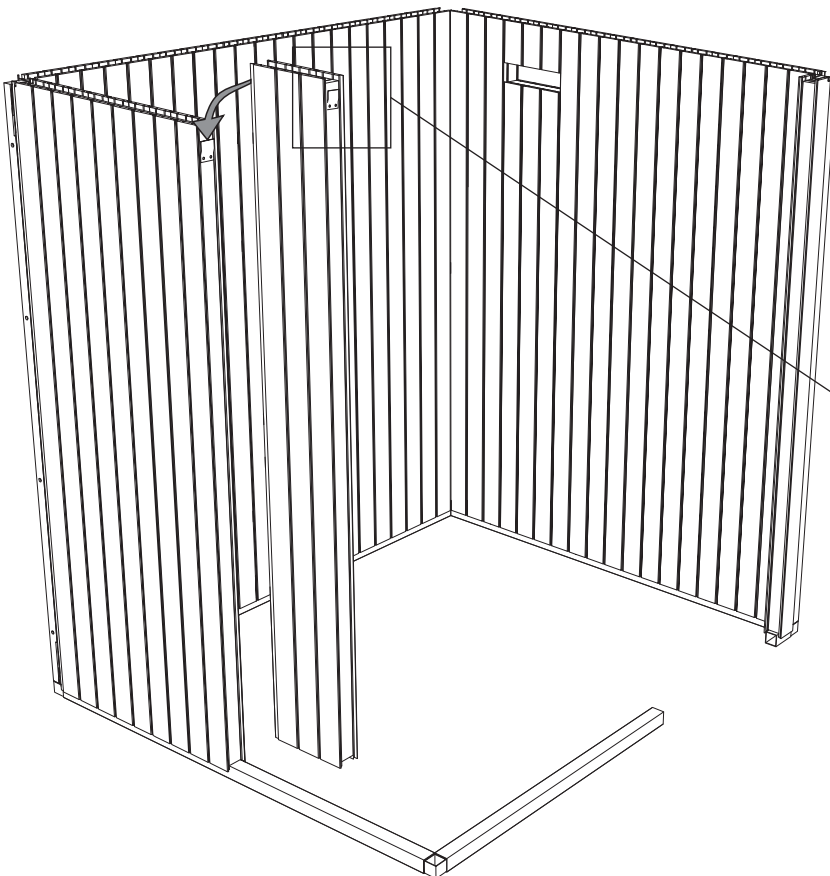
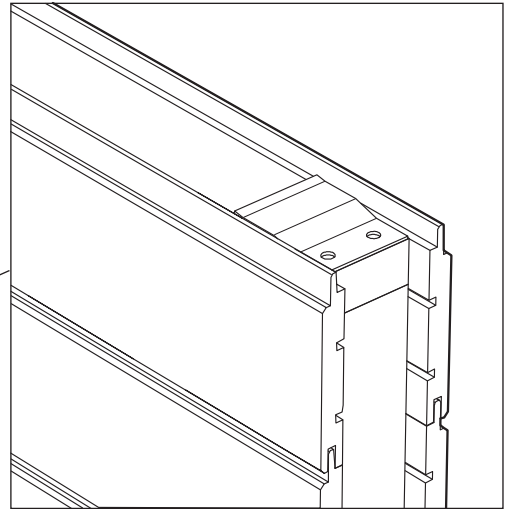
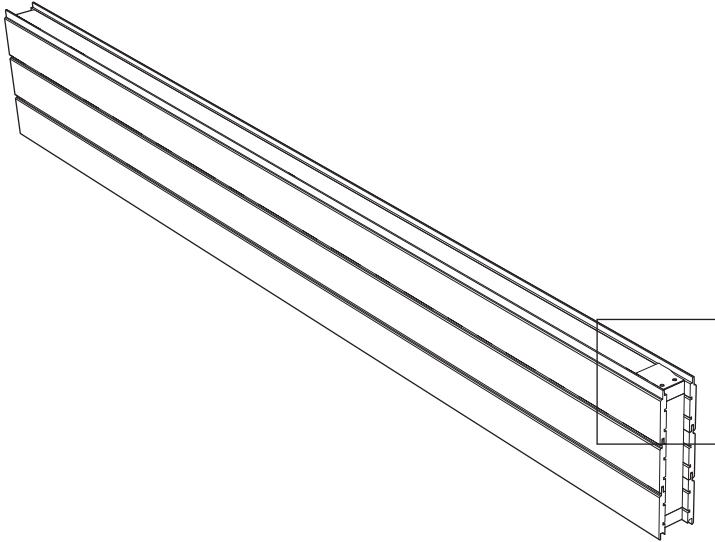
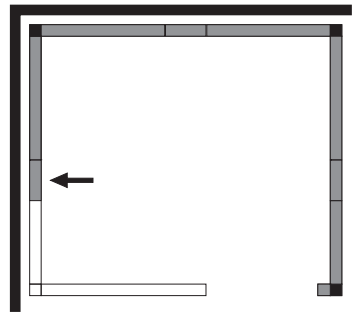
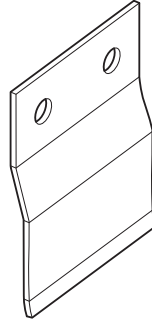
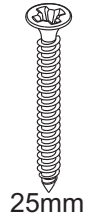
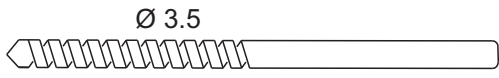

26

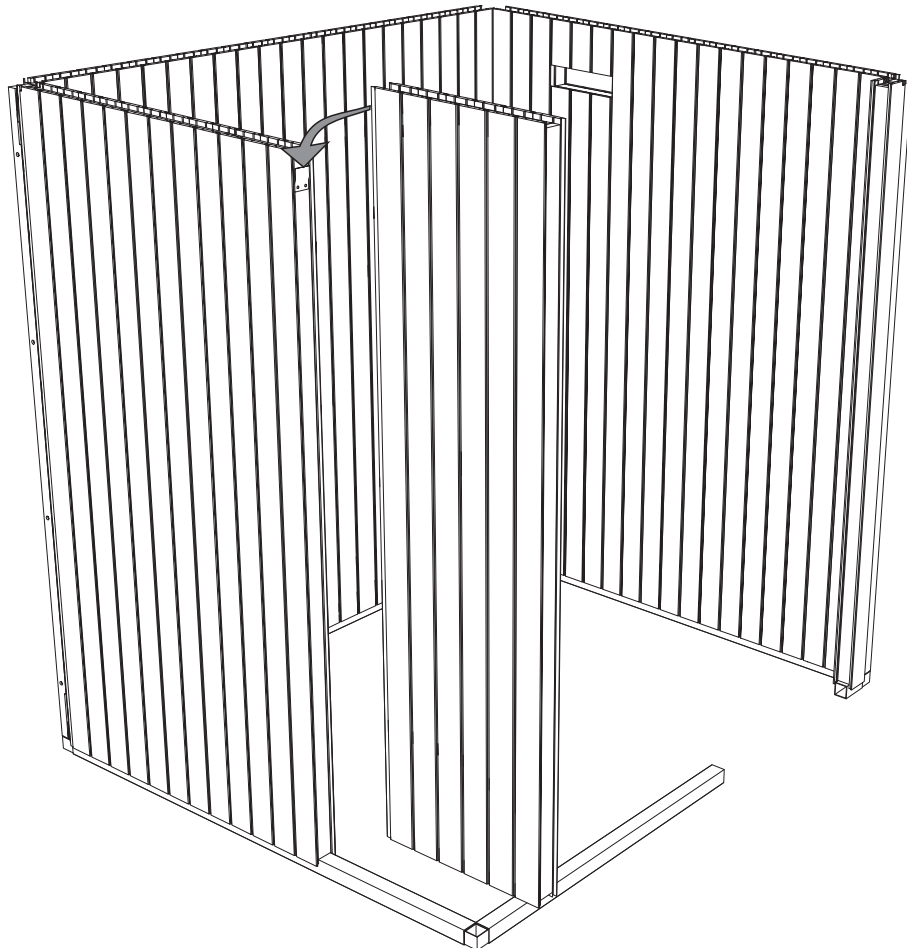
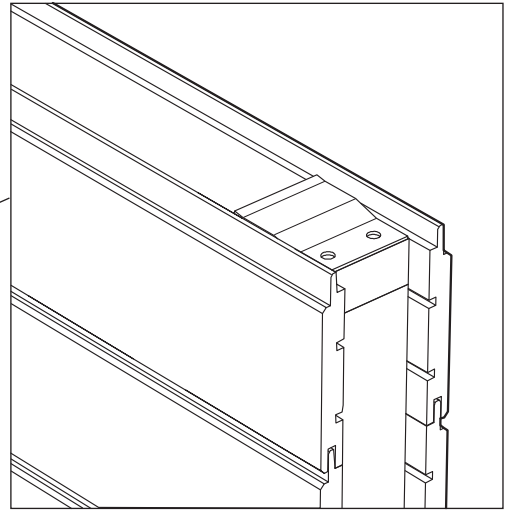
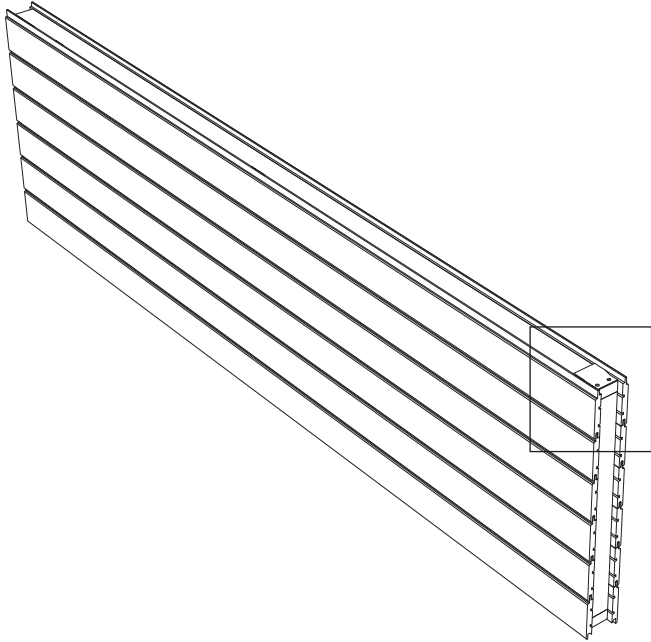
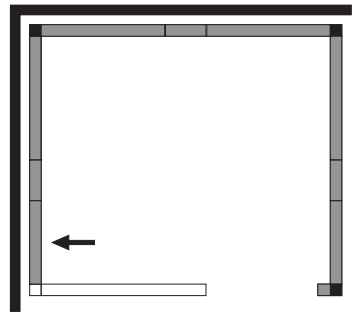
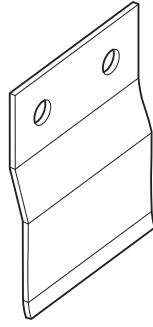
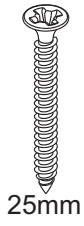
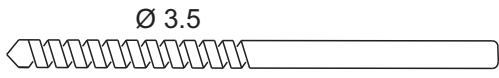

27

P3

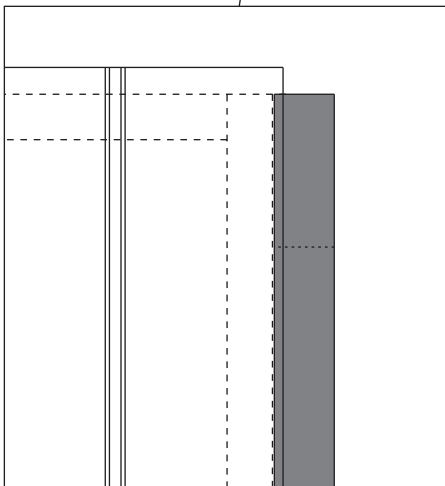
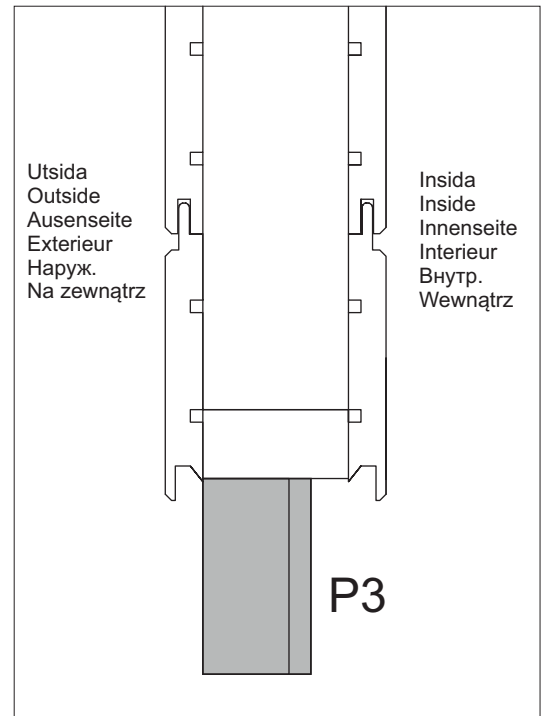
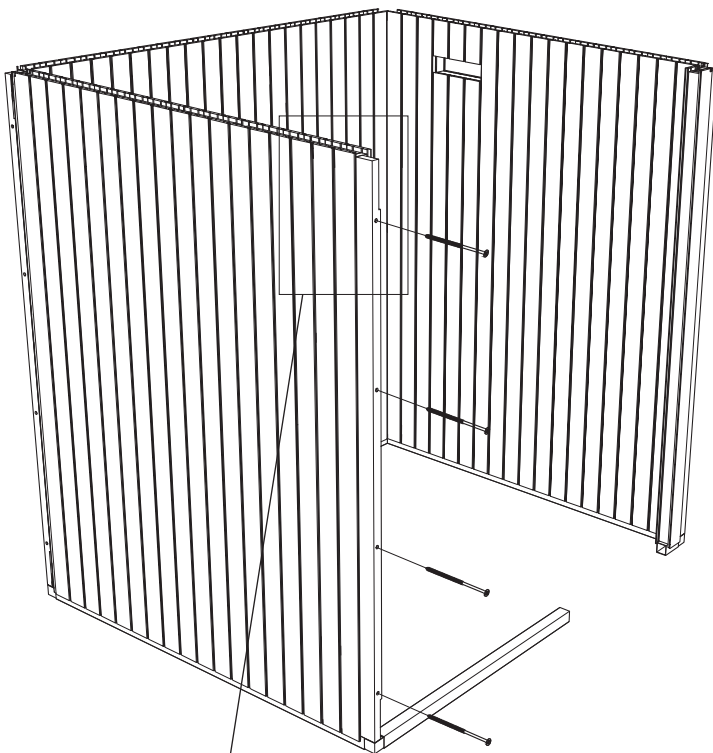
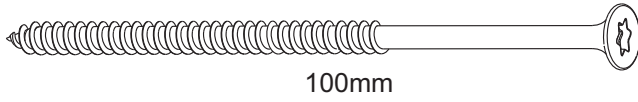
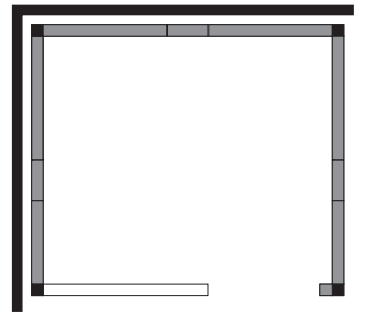
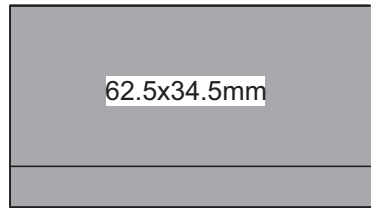

28

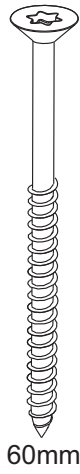

60mm

P2

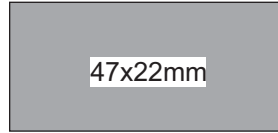

47x22mm

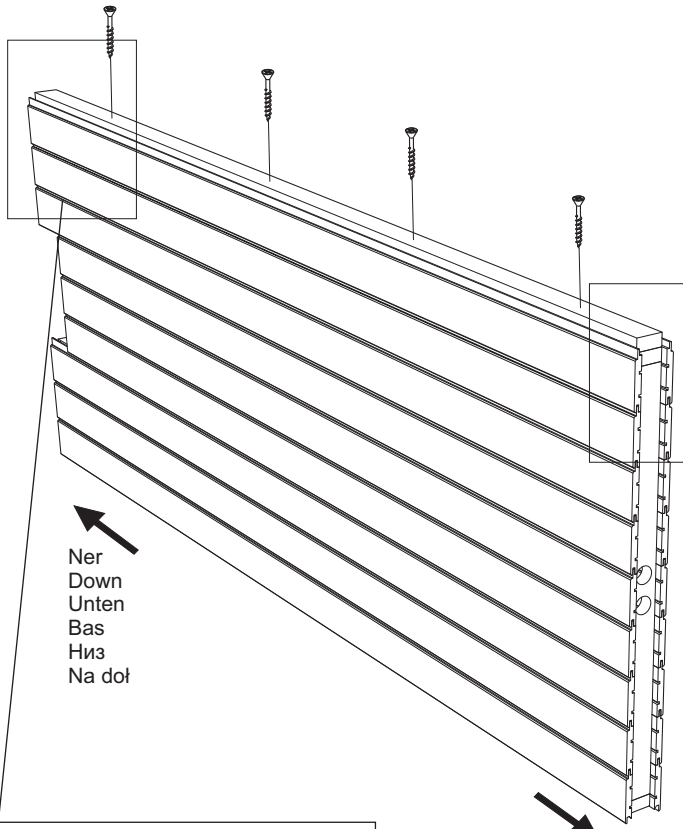
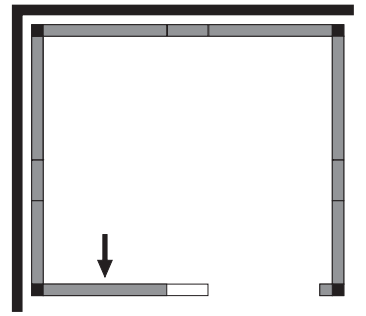

Ner
Down
Unten
Bas
Низ
На доł

Upp
Up
Oben
Haut
Вверх
До гору

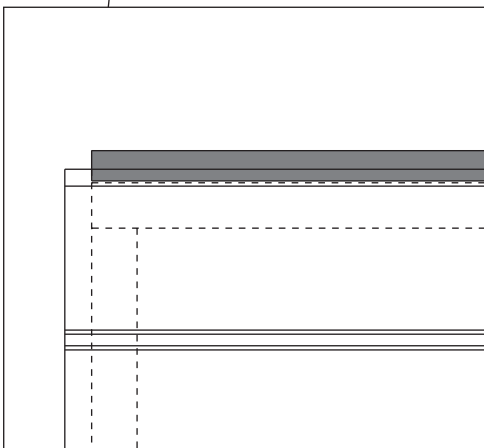
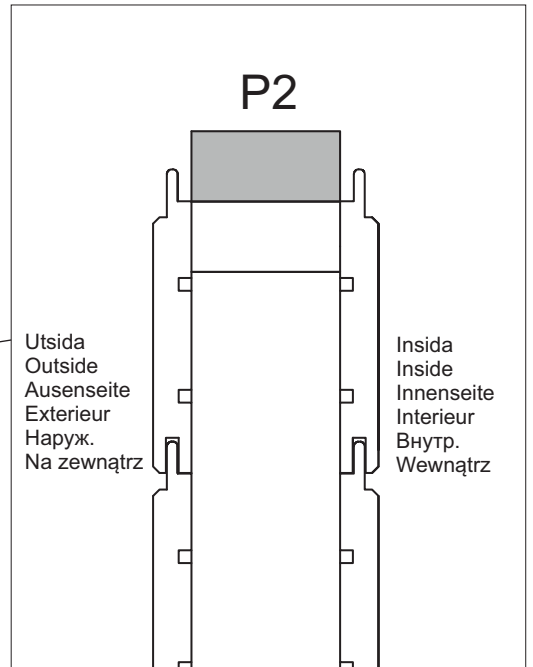

29

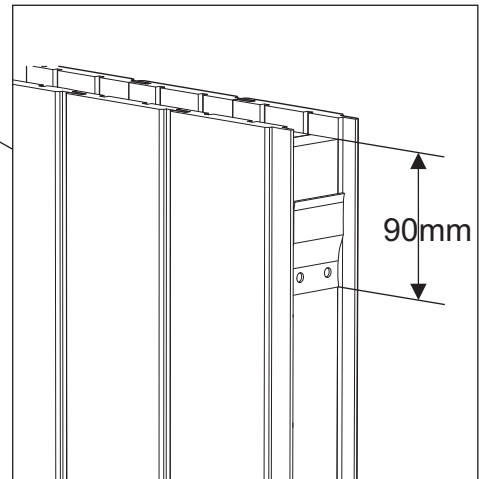
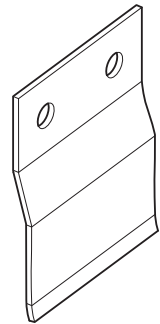
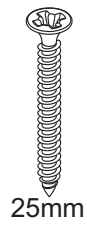
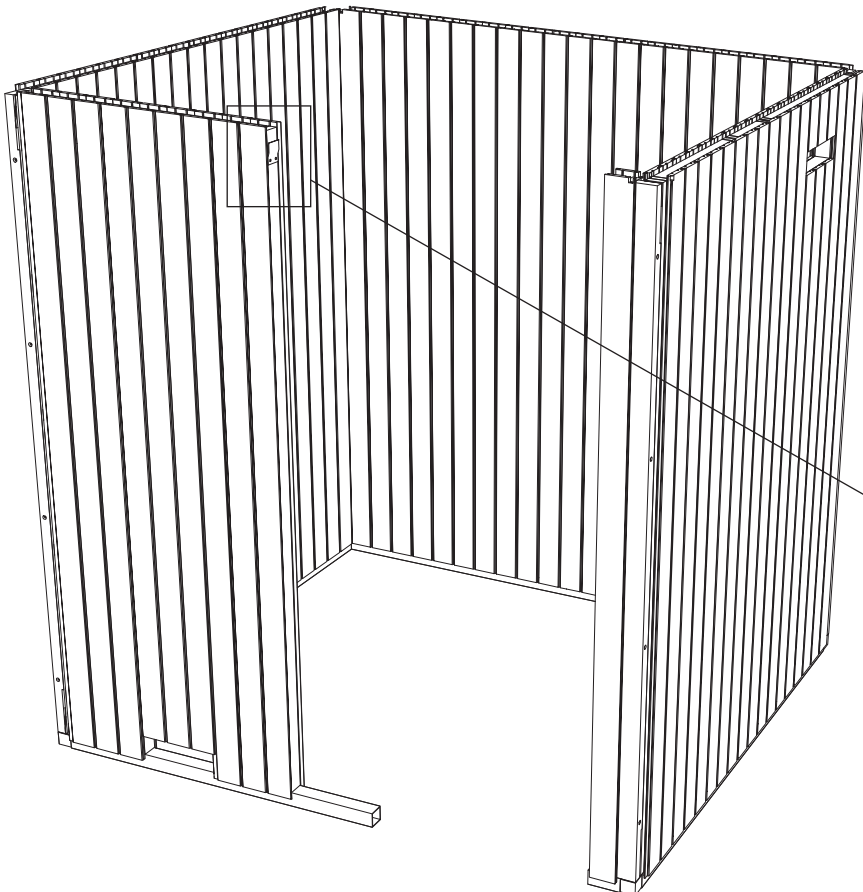
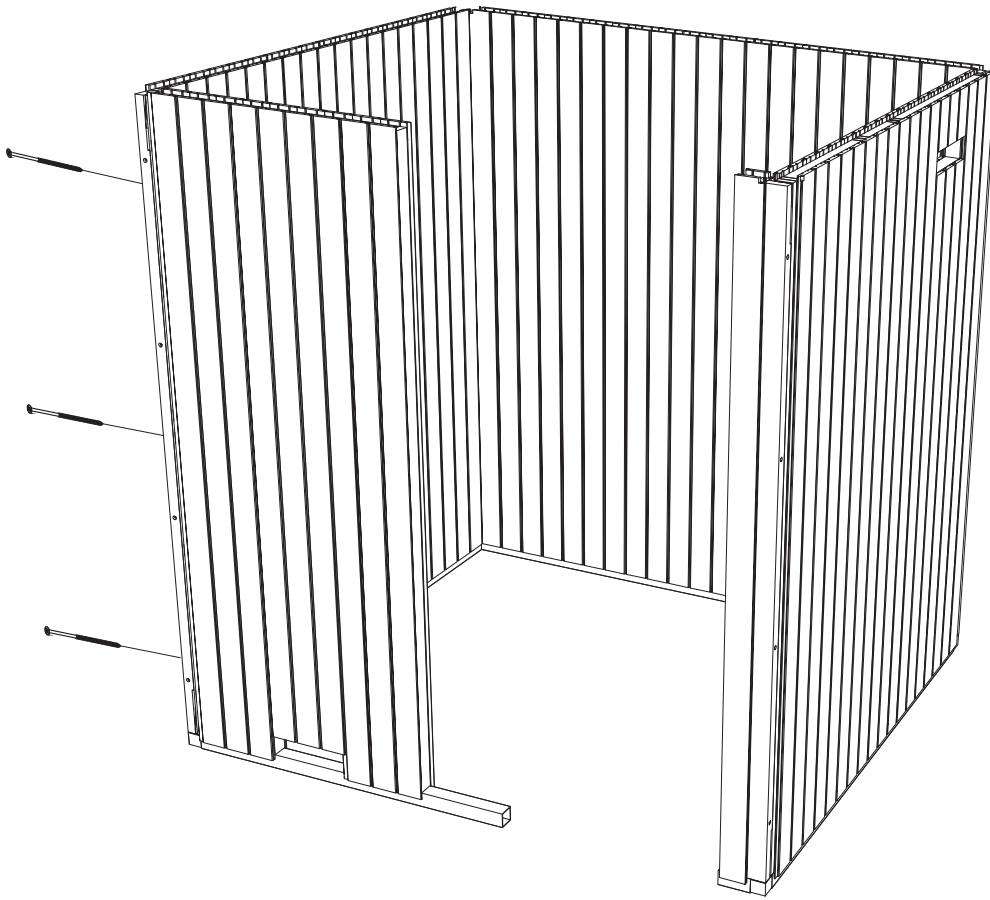
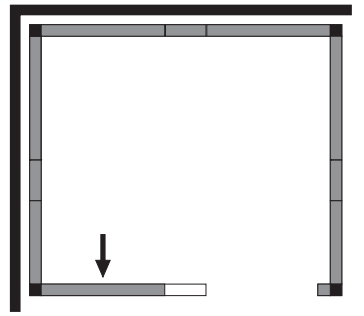
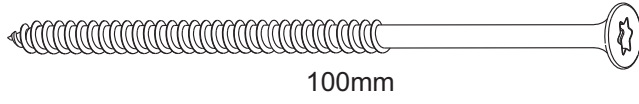

30

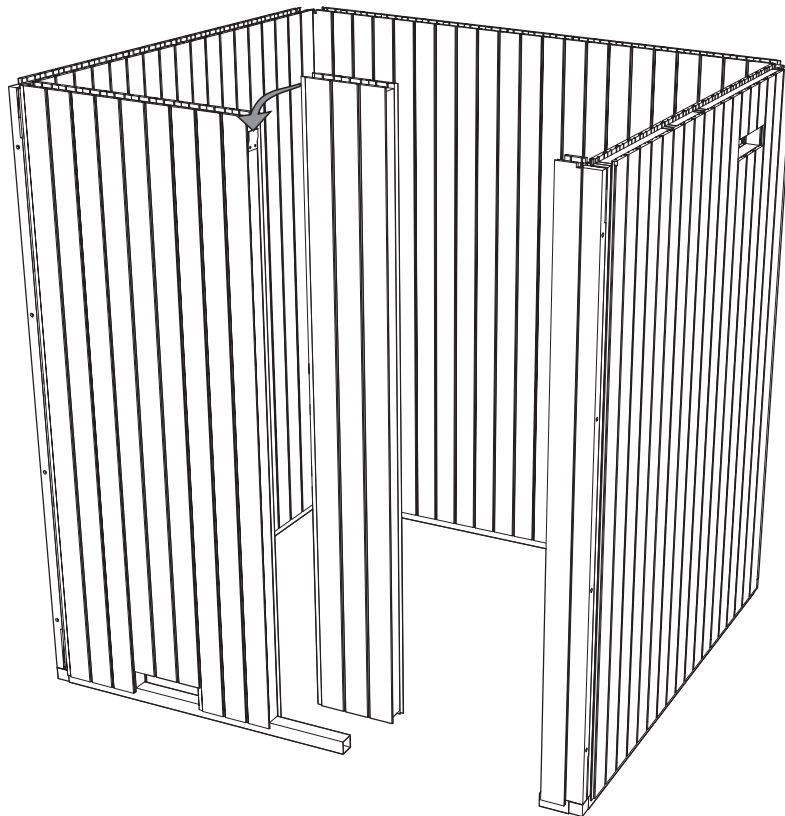
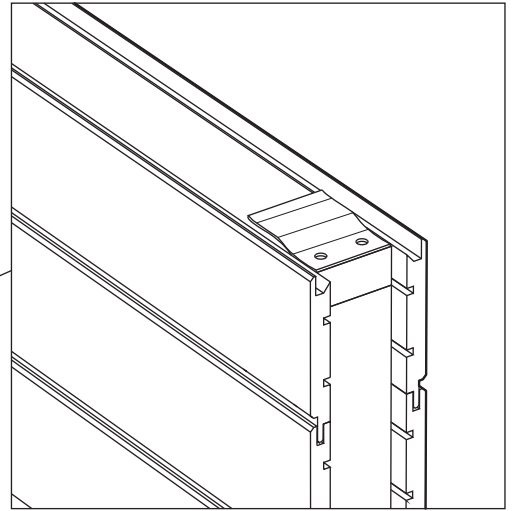
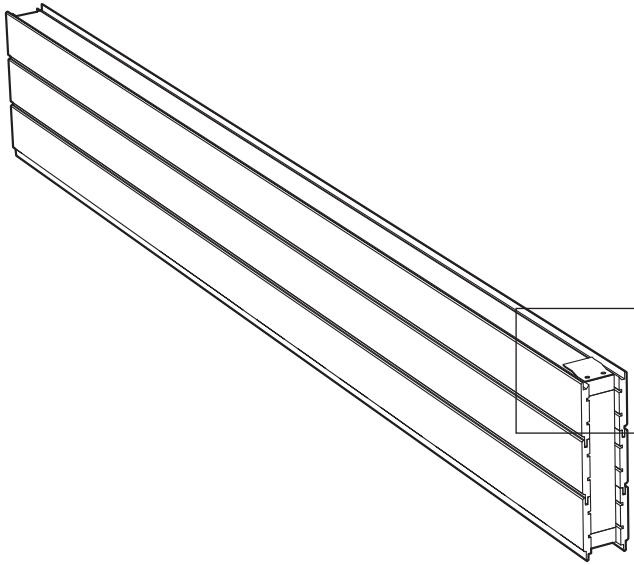
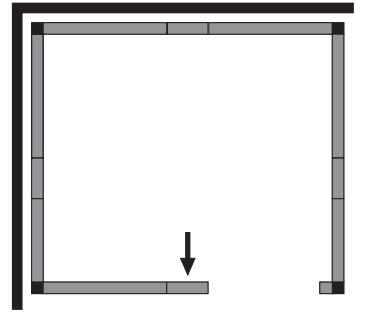
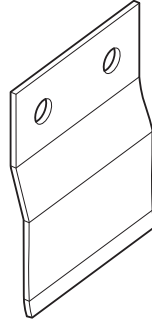
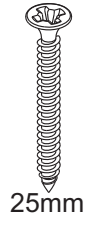
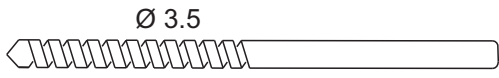

P6

2x1750mm

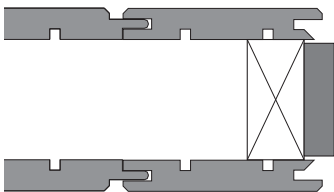
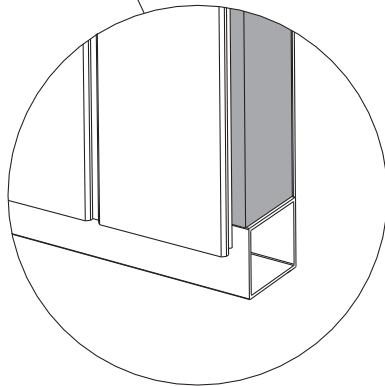
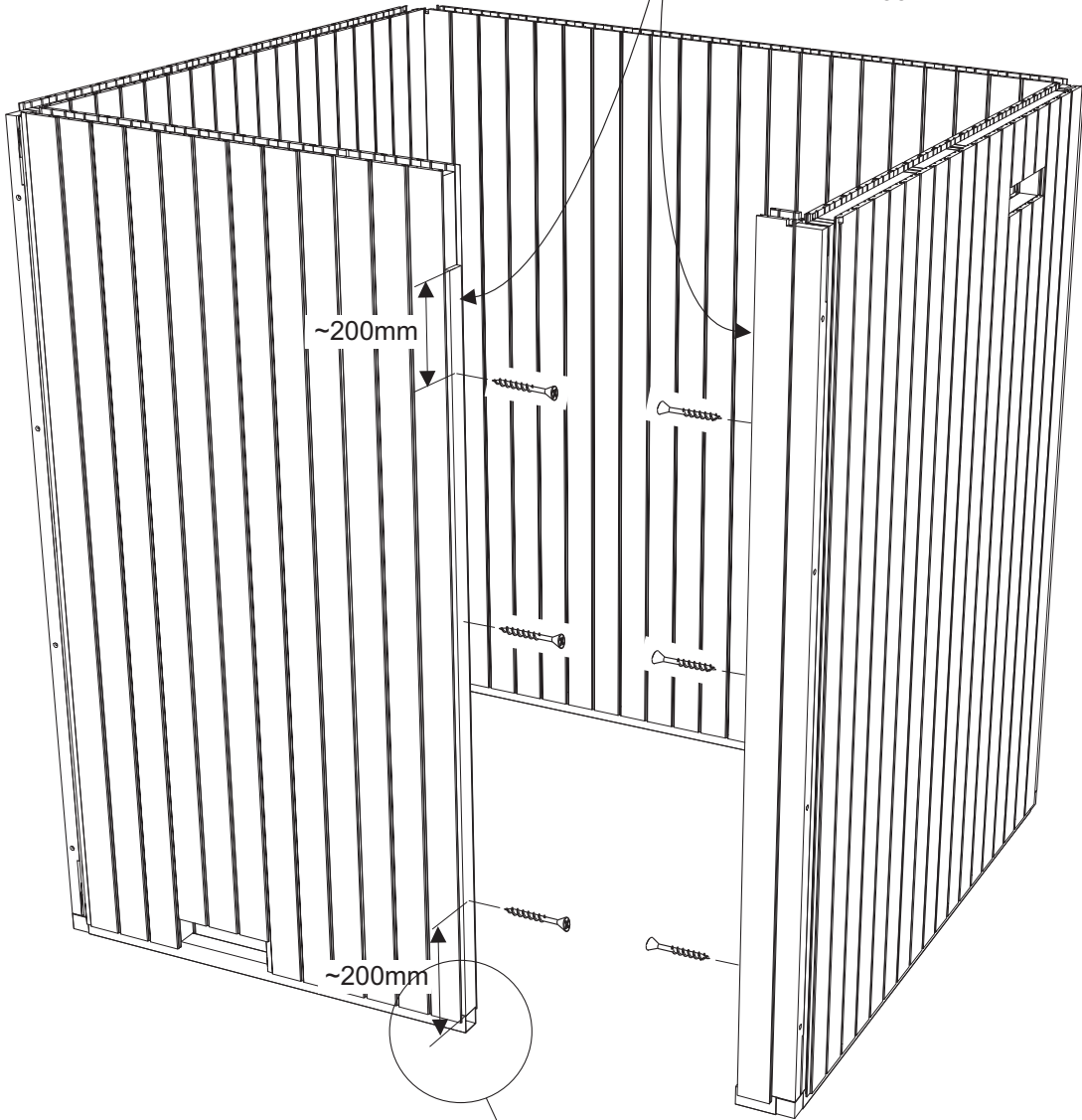
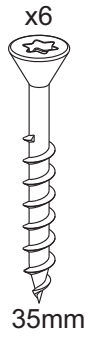

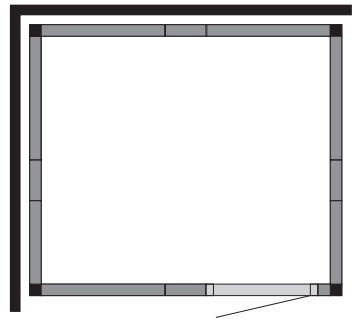

Dörr utan tröskel
Door without treshold
Drzwi bez prog

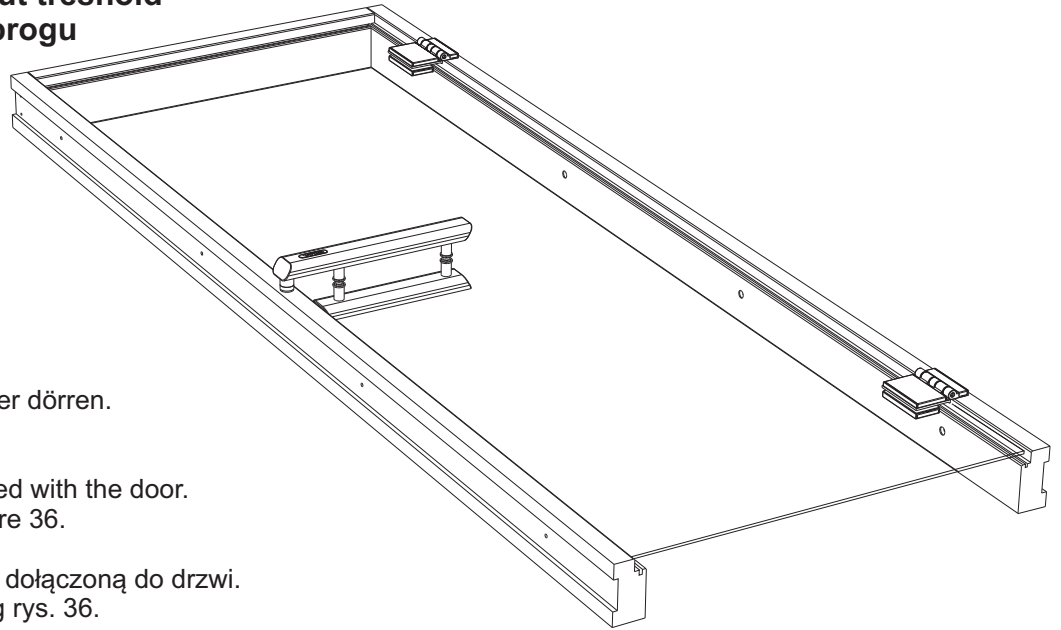

Följ anvisningen som medföljer dörren.
Använd silicon enligt bild 36.

Follow the instructions supplied with the door.
Use silicon according to picture 36.

Postępuj zgodnie z instrukcją dołączoną do drzwi.
Zastosowanie silikonu według rys. 36.

33

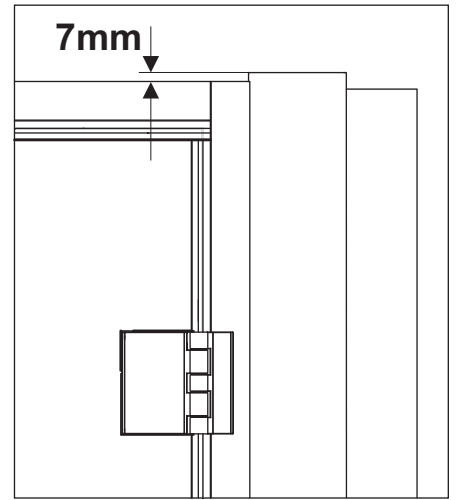
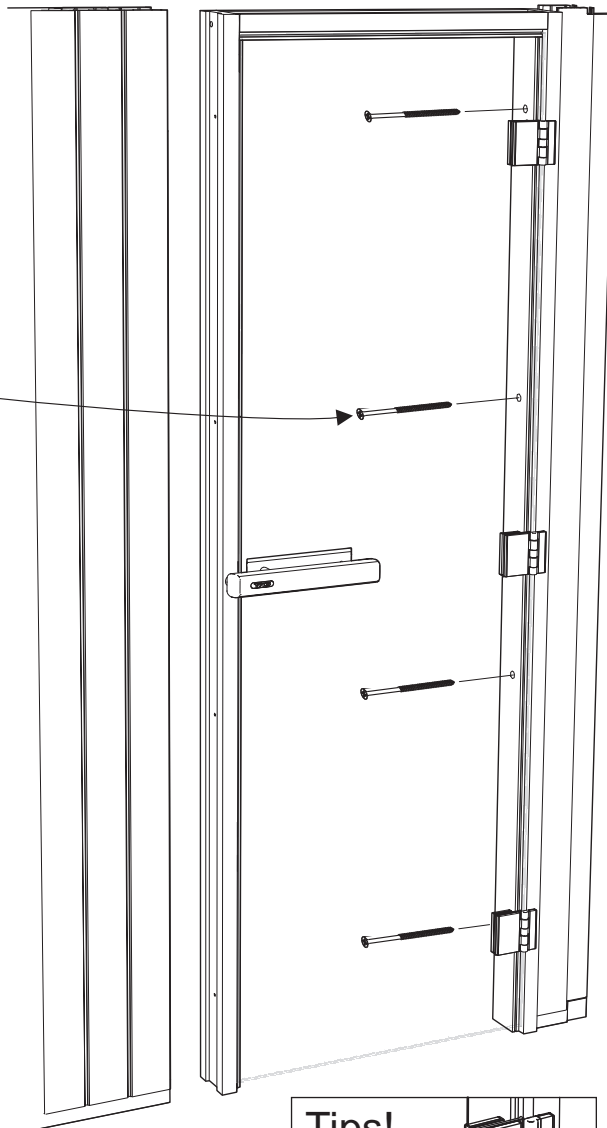
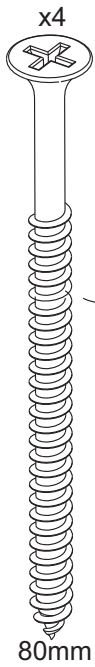
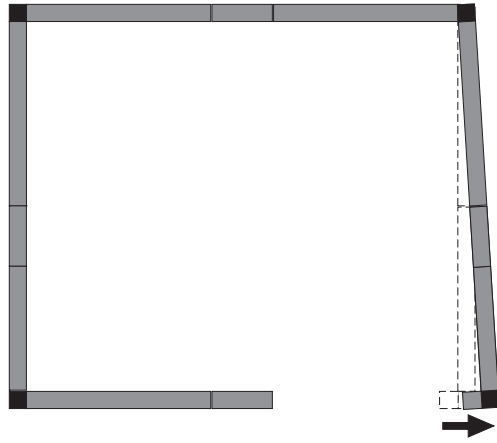

**OBS!
NOTE!
UWAGA!**

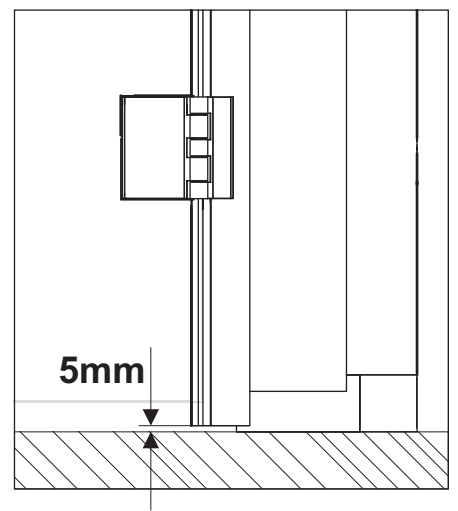

**Tips!
Tip!
Porada!**

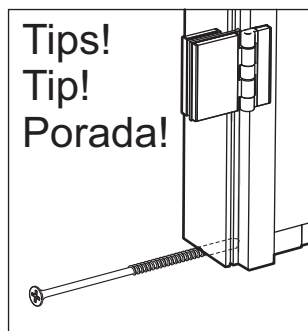

34

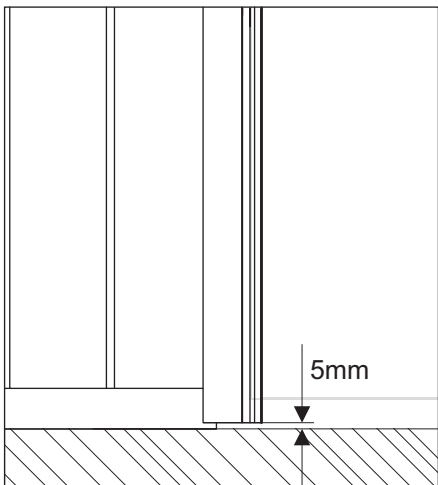
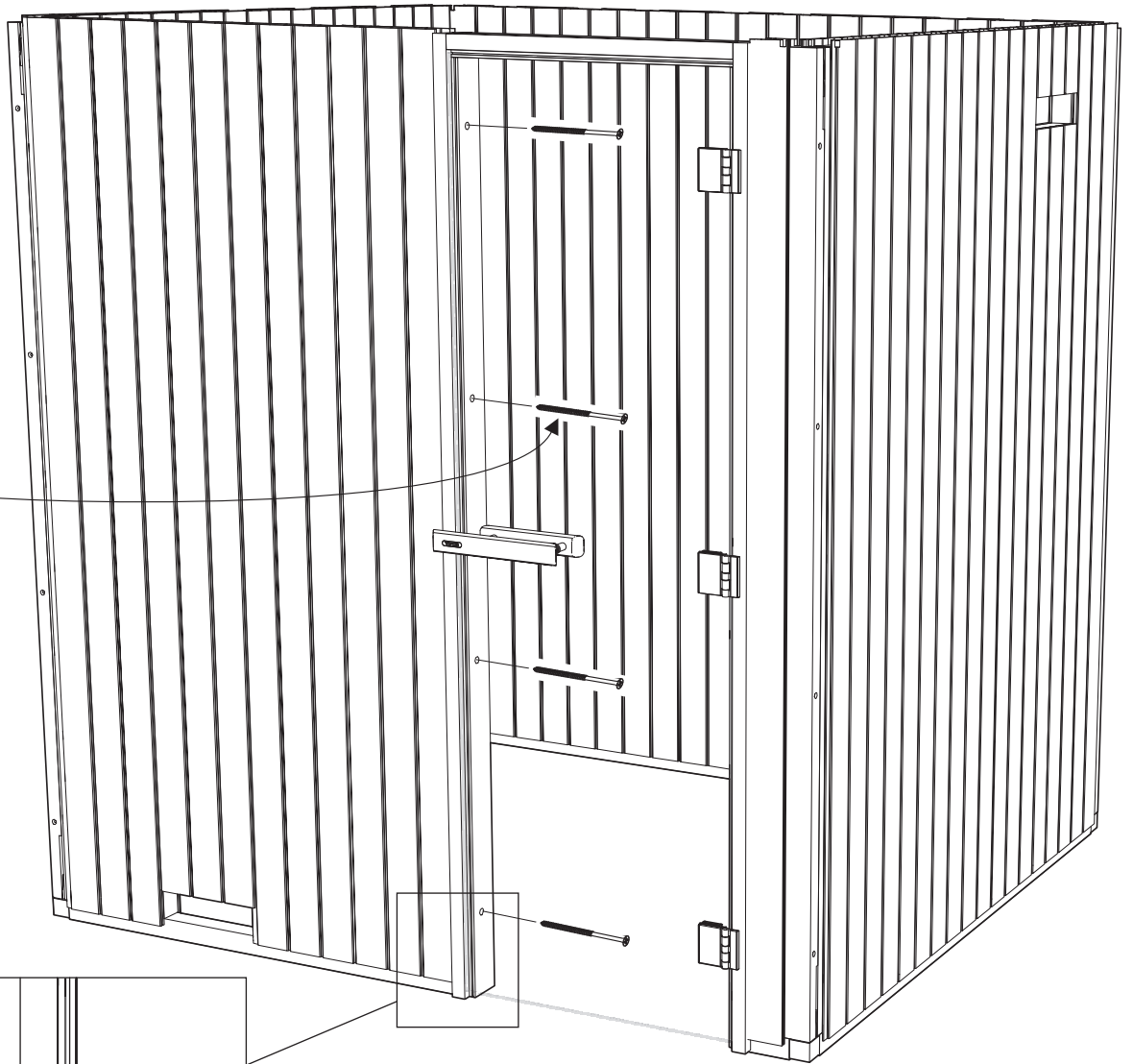
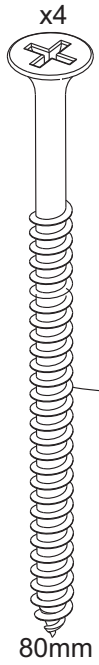
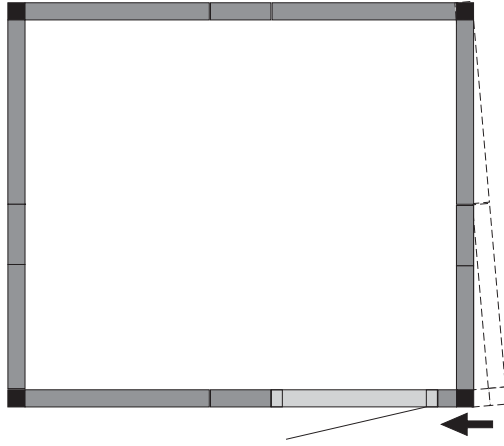

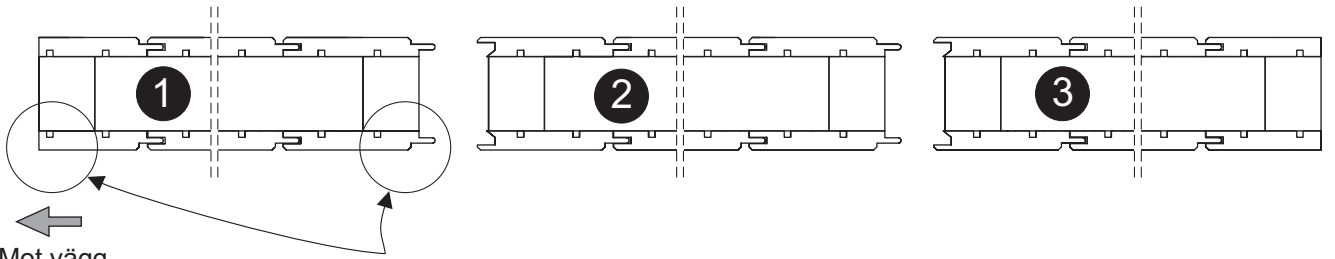

Mot vägg
Against wall
Do ściany

OBS!
N.B.!
UWAGA!

Styrlister - se nästa sida
Guide bars - see next page

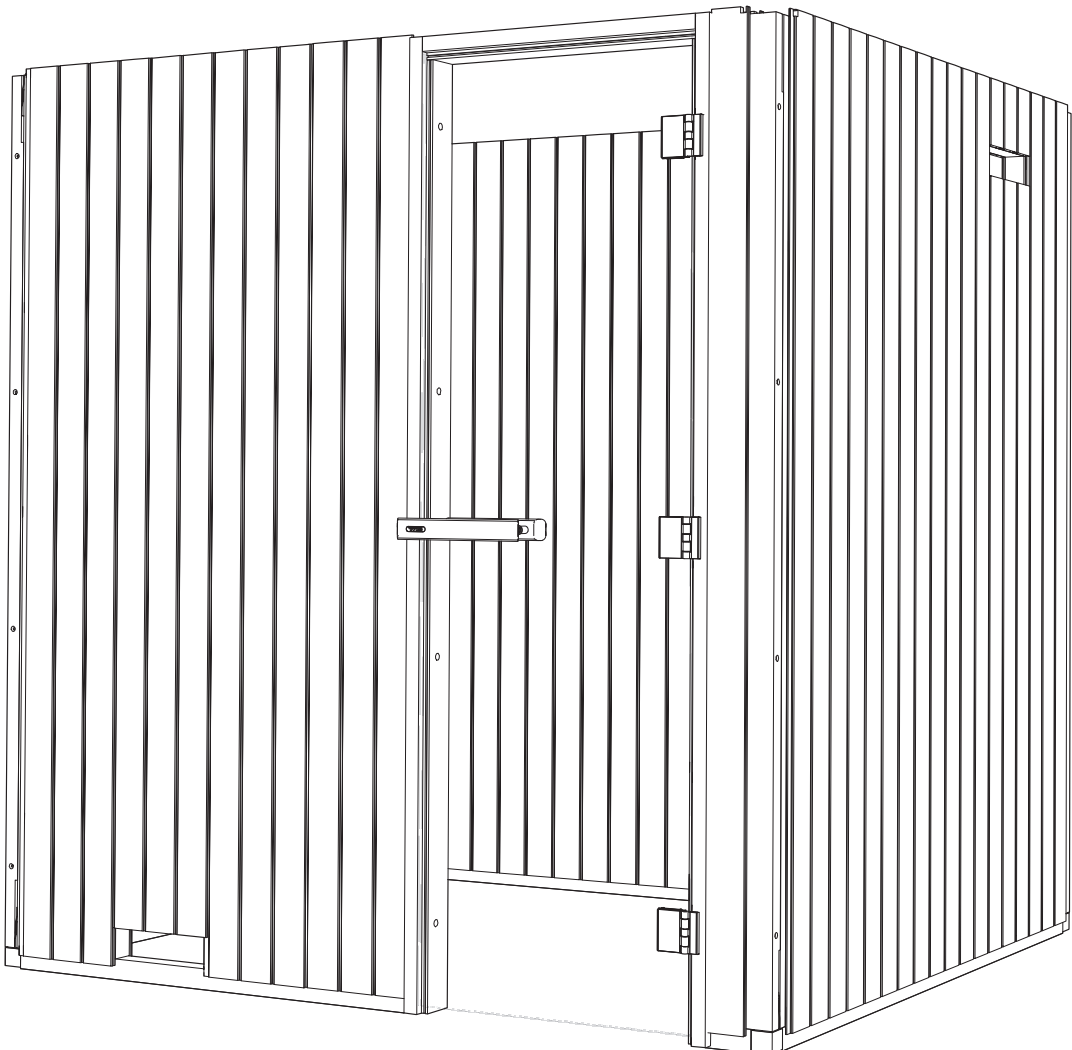
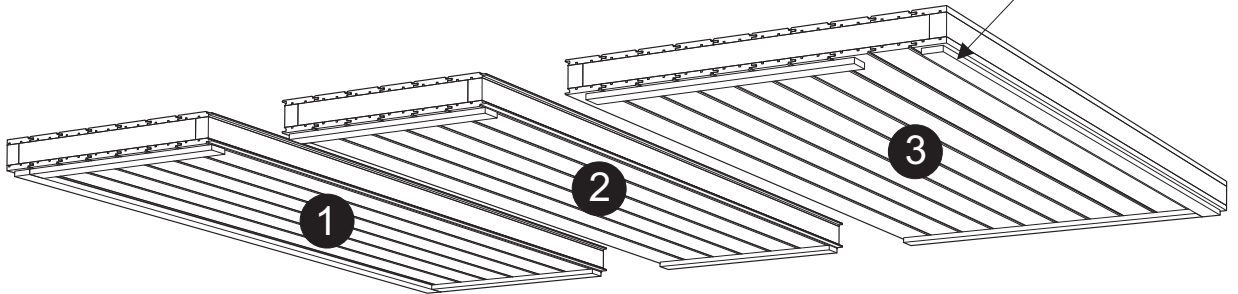

36

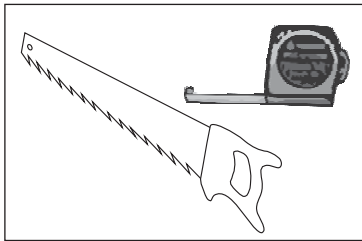

P6

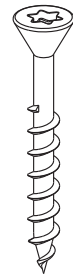

35mm

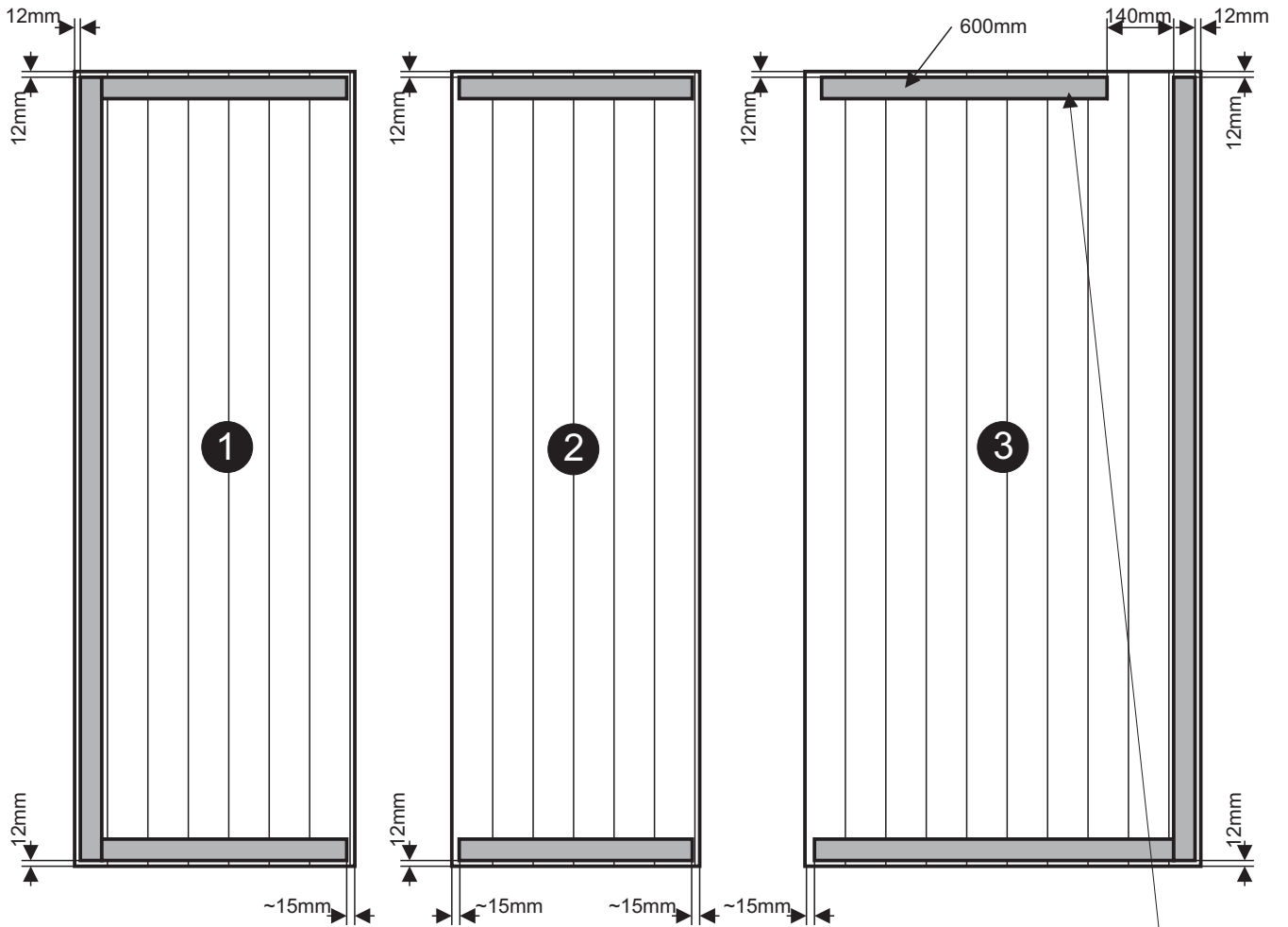

Ovanför dörr
Above door

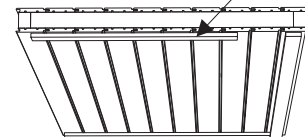

Se layouten som medföljer rummet.
See the layout that comes with the sauna room.

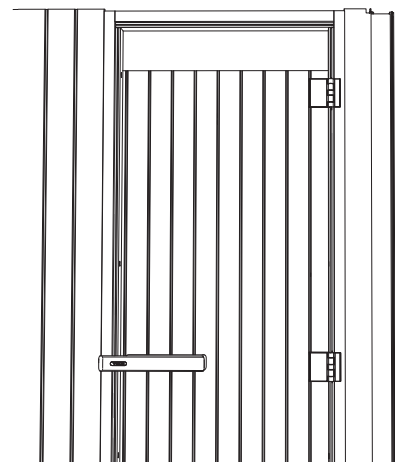

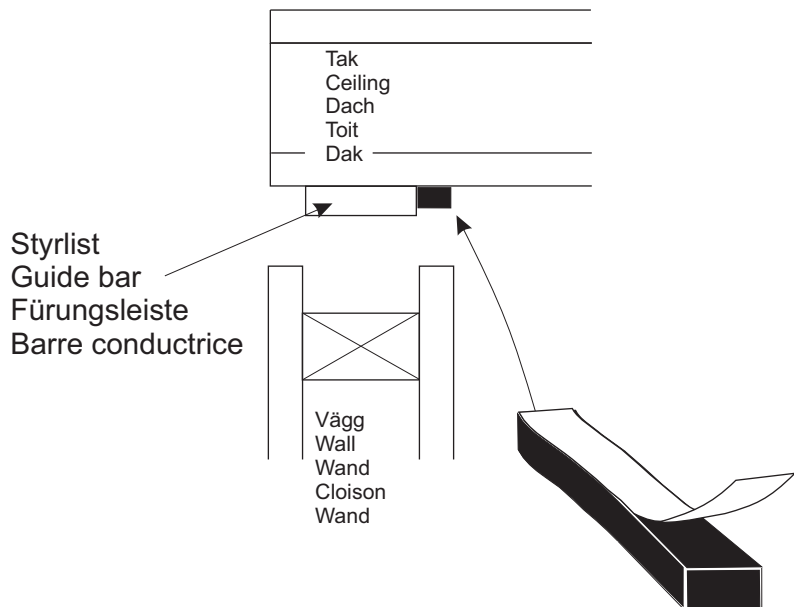
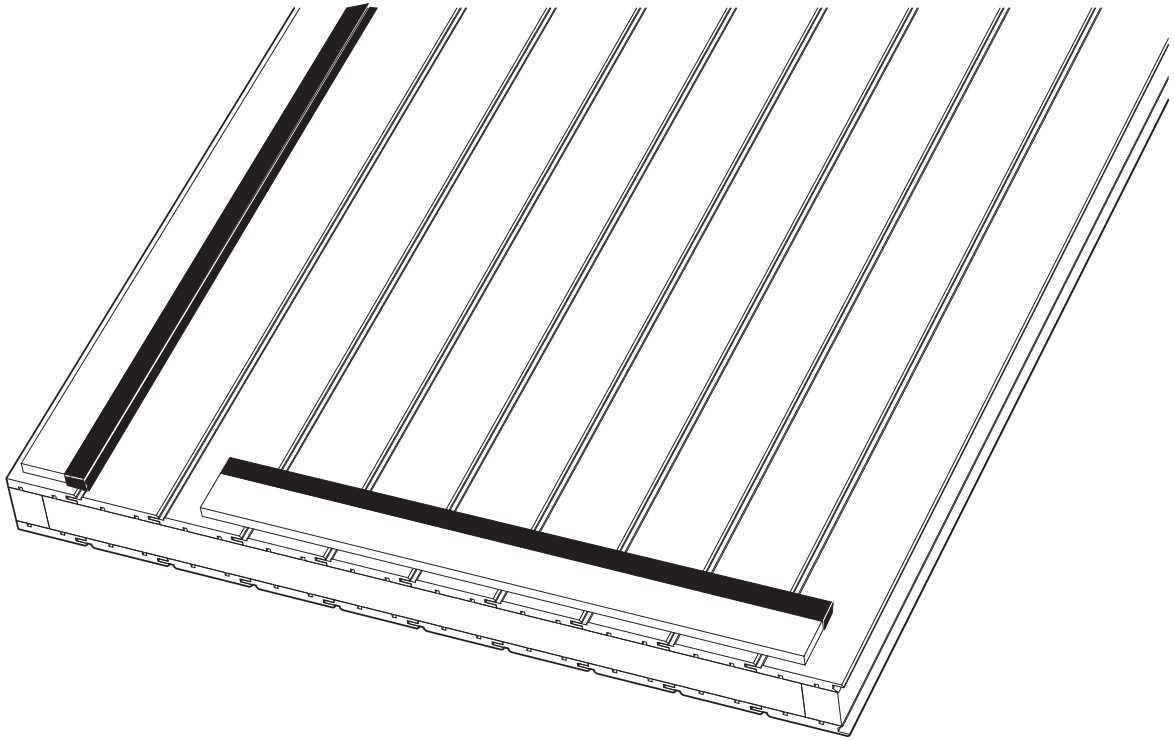
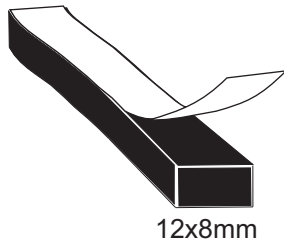

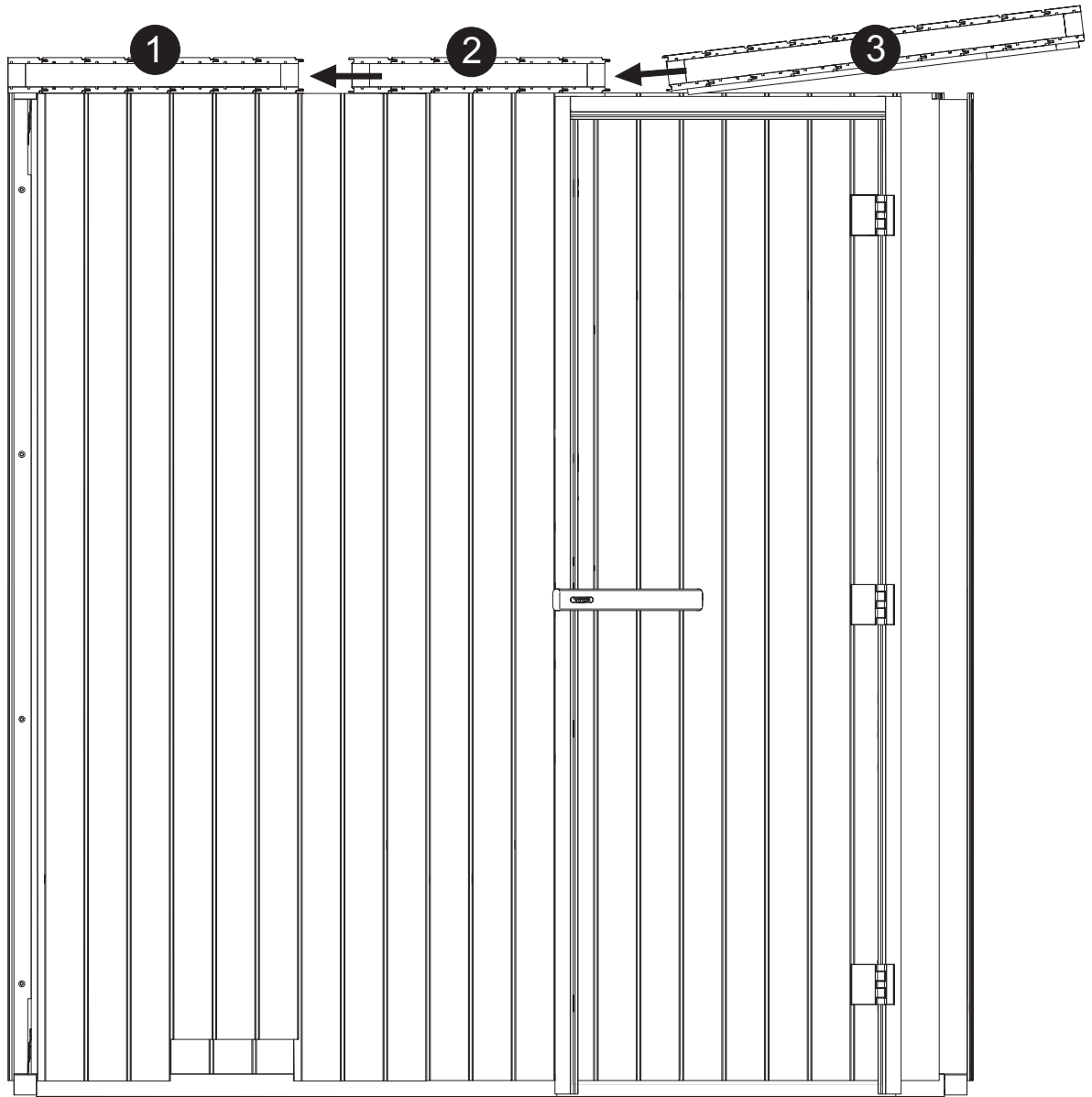

Alternativ
Option

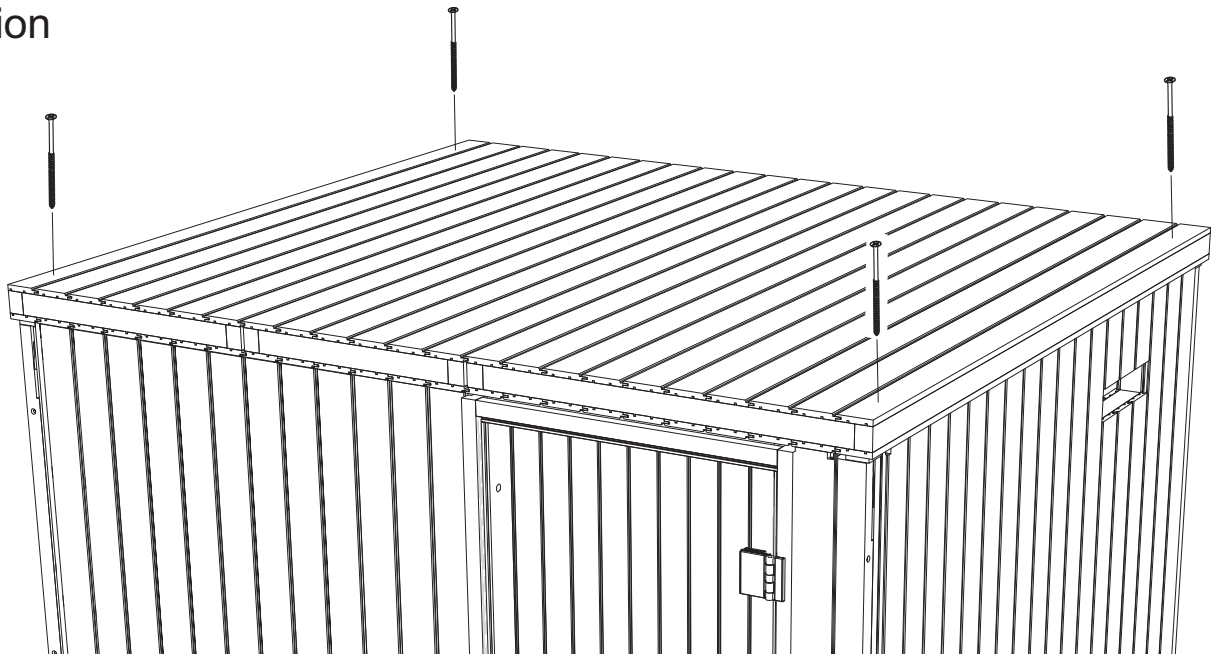
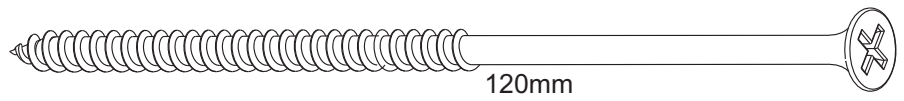

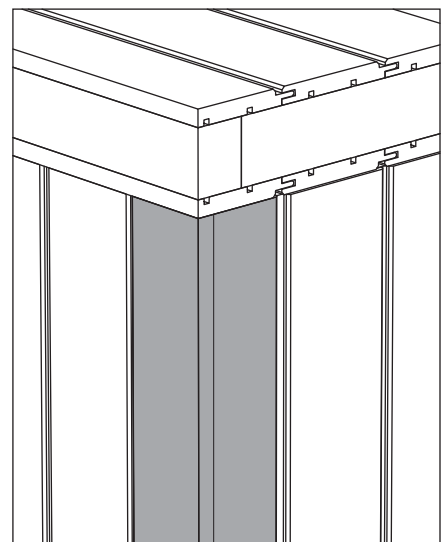
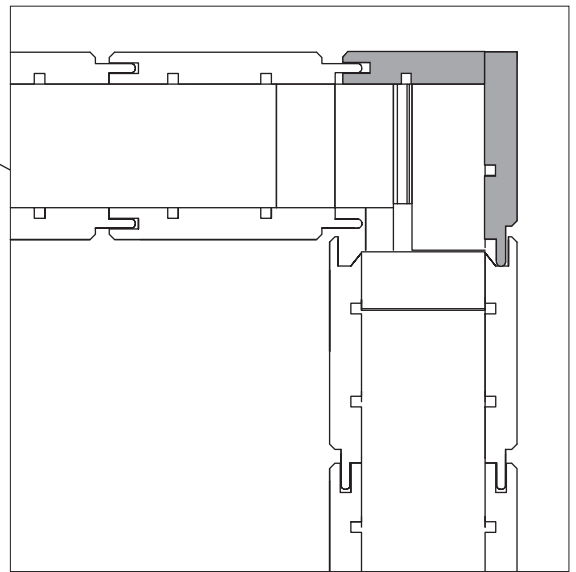
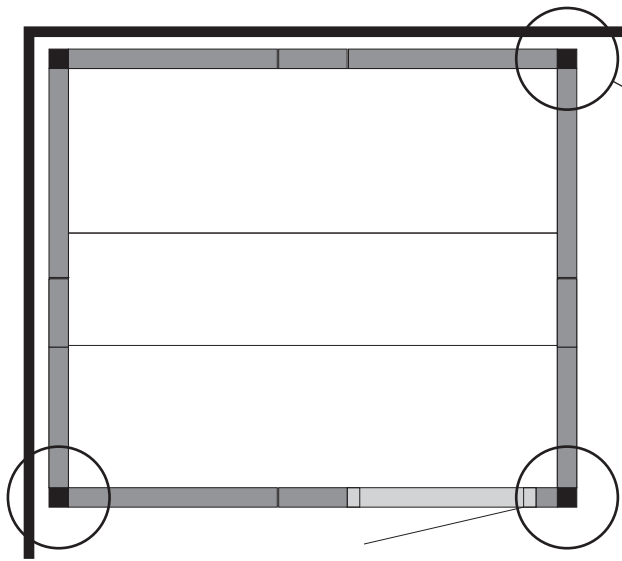
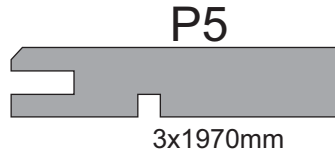
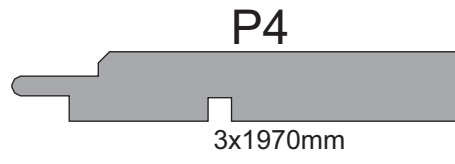

40

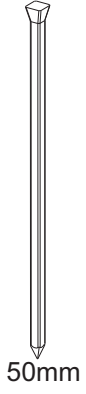

P7

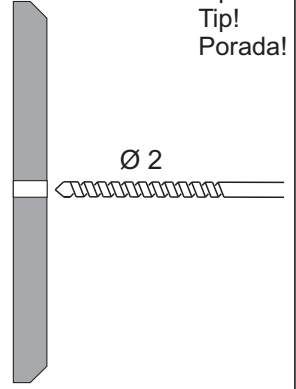

Tips!
Tip!
Porada!

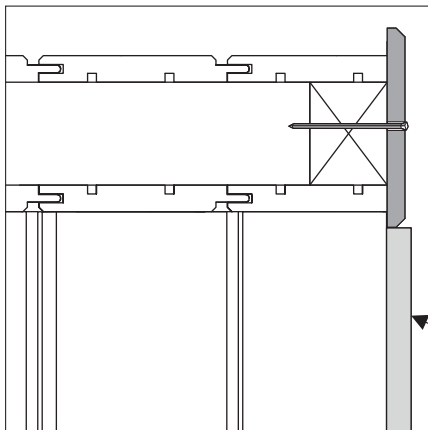
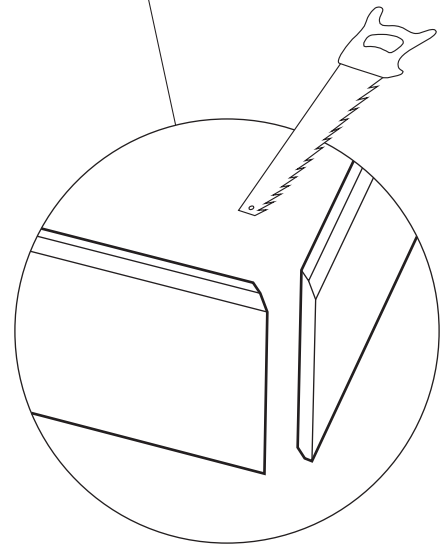
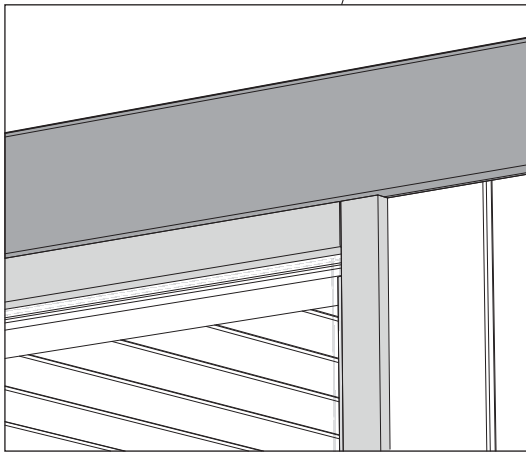
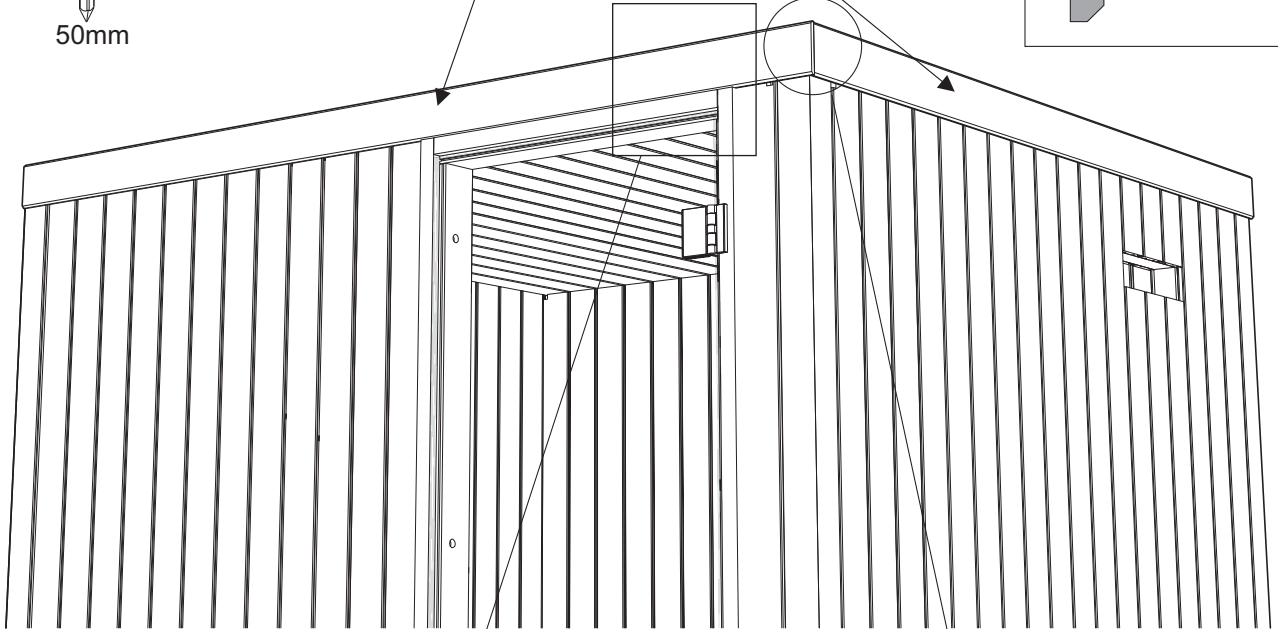

Dörrkarm
Door frame

41

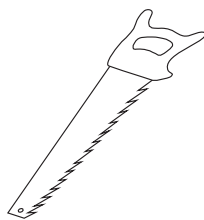
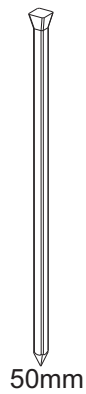

Tips!
Tip!
Porada!

Ø 2

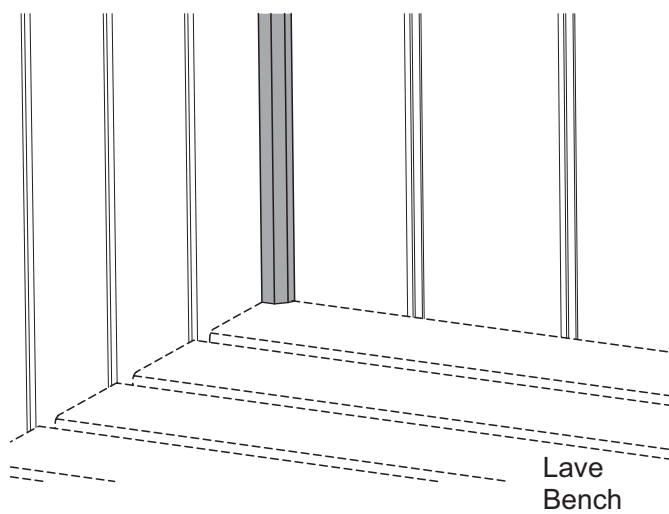
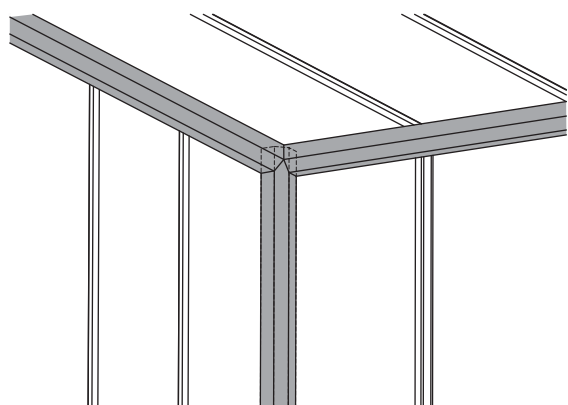

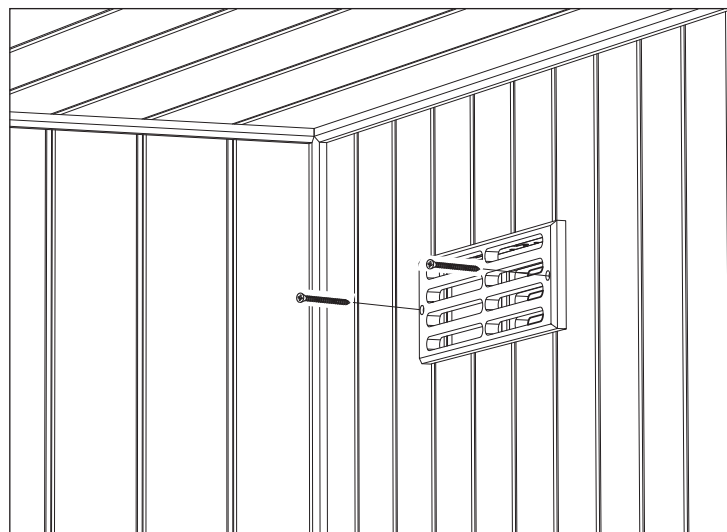
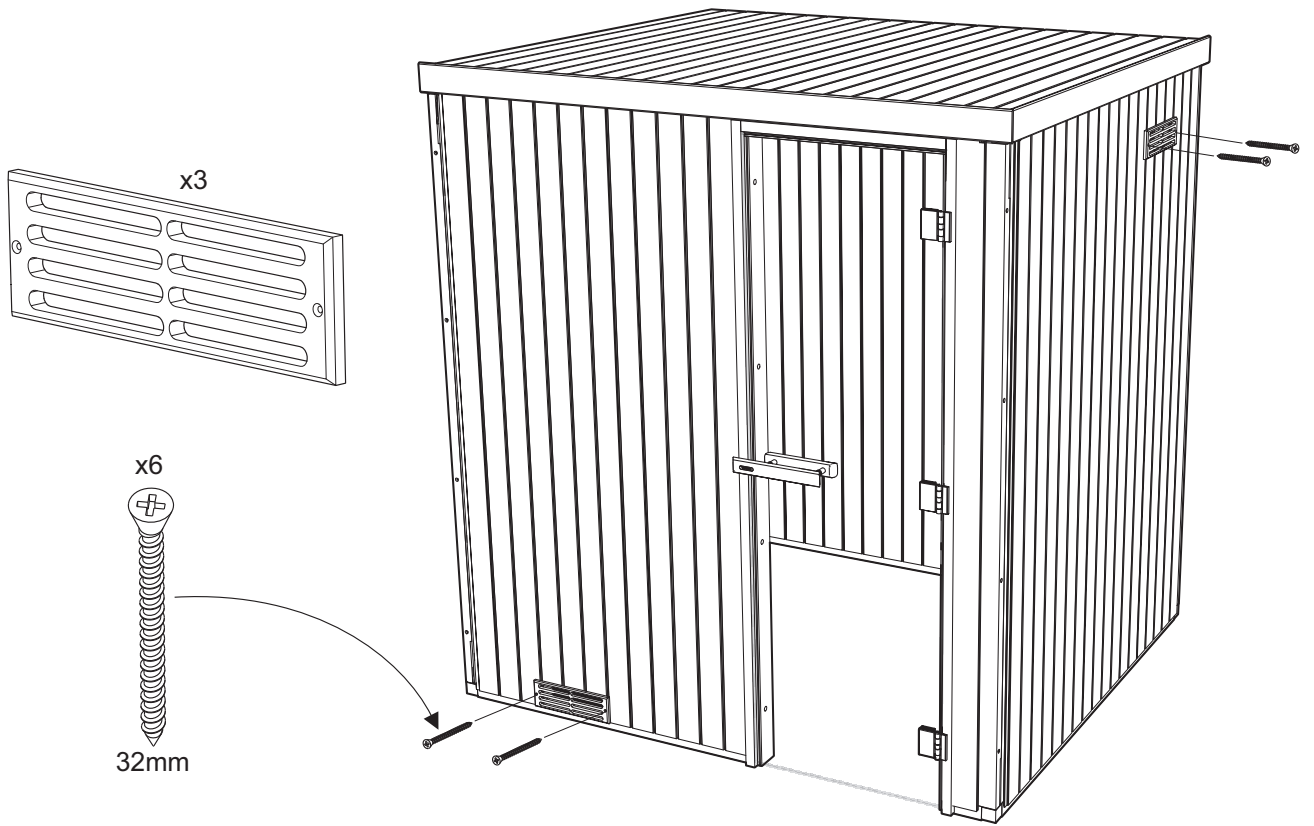

43

Använd silikon längs golvprofilen vid montering av dörr utan tröskel

Use silicon along the floor profile when assembling the door without treshold

Zastosuj silikon wzdłuż profilu ramy podłogowej przy montażu drzwi bez progów

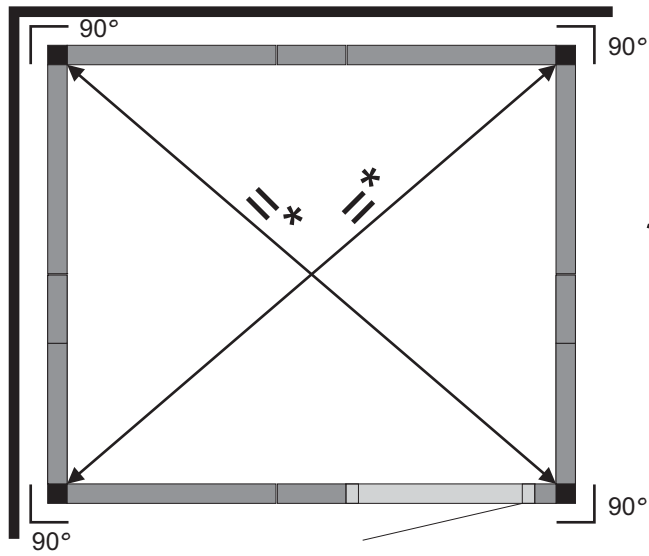

* Måtten skall vara lika på diagonalen
The dimensions must be equal on the diagonal
Wymiary przekątnych muszą być równe

