

# TYLÖ SAUNA EVOLVE CORNER

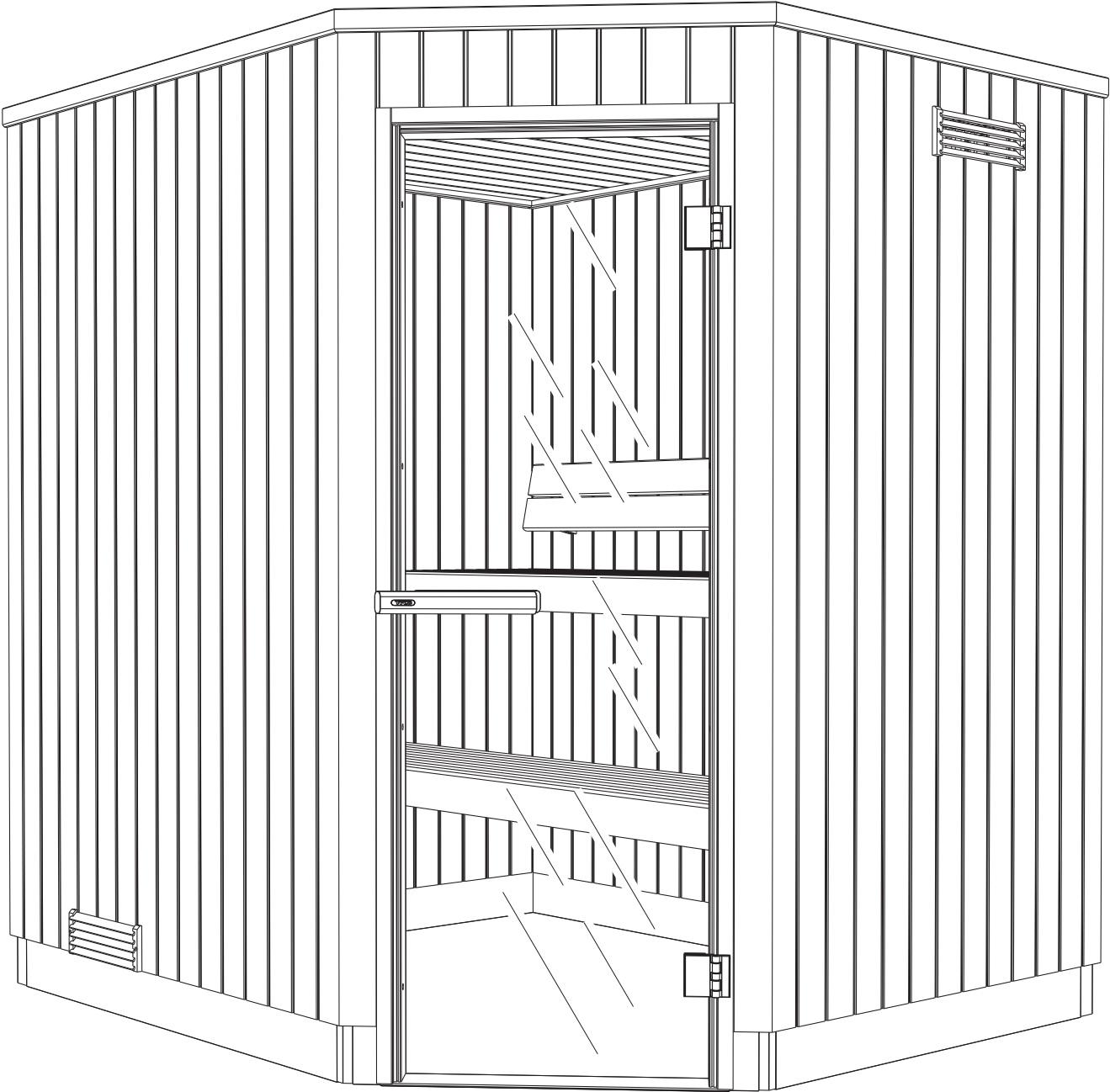

Väggsektion för aggregat

Wall section for heater

Moduł ścianki do montażu pieca do sauny

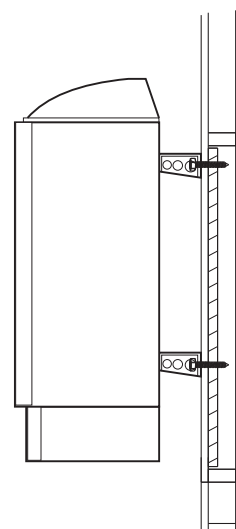
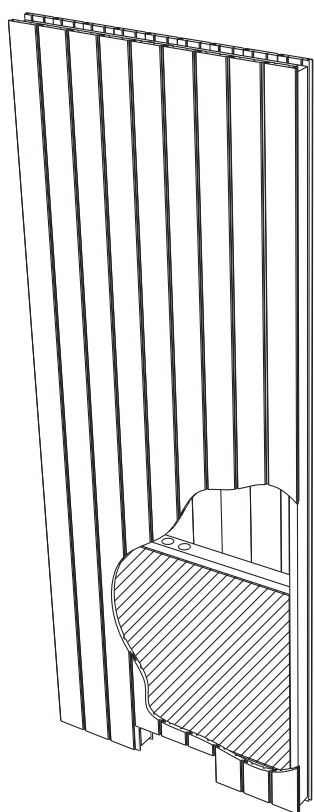
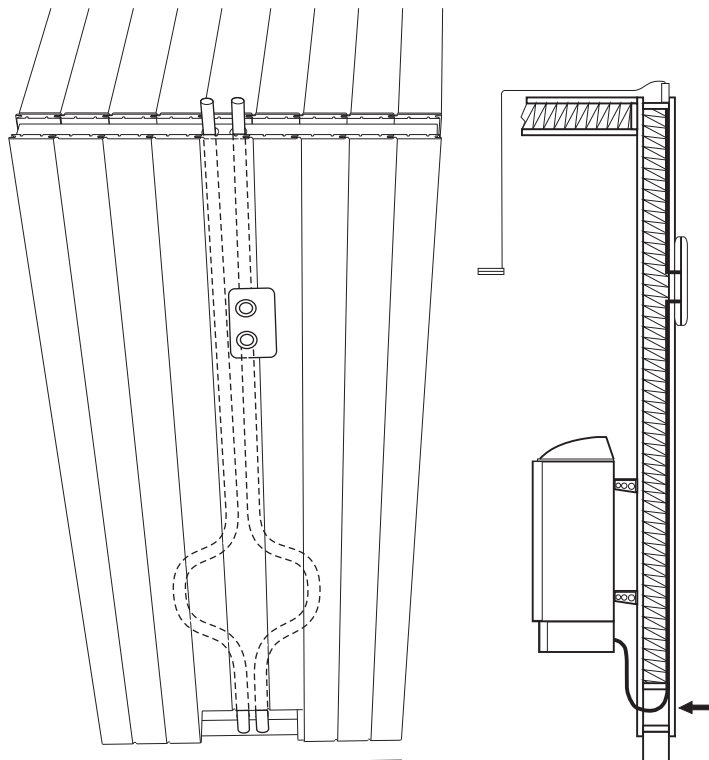
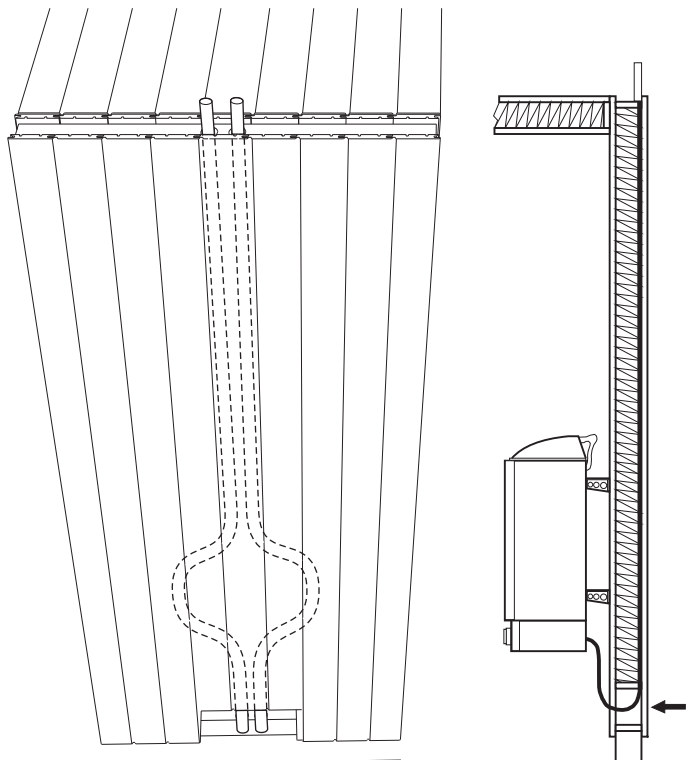

Tips!  
Tip!  
Porada!

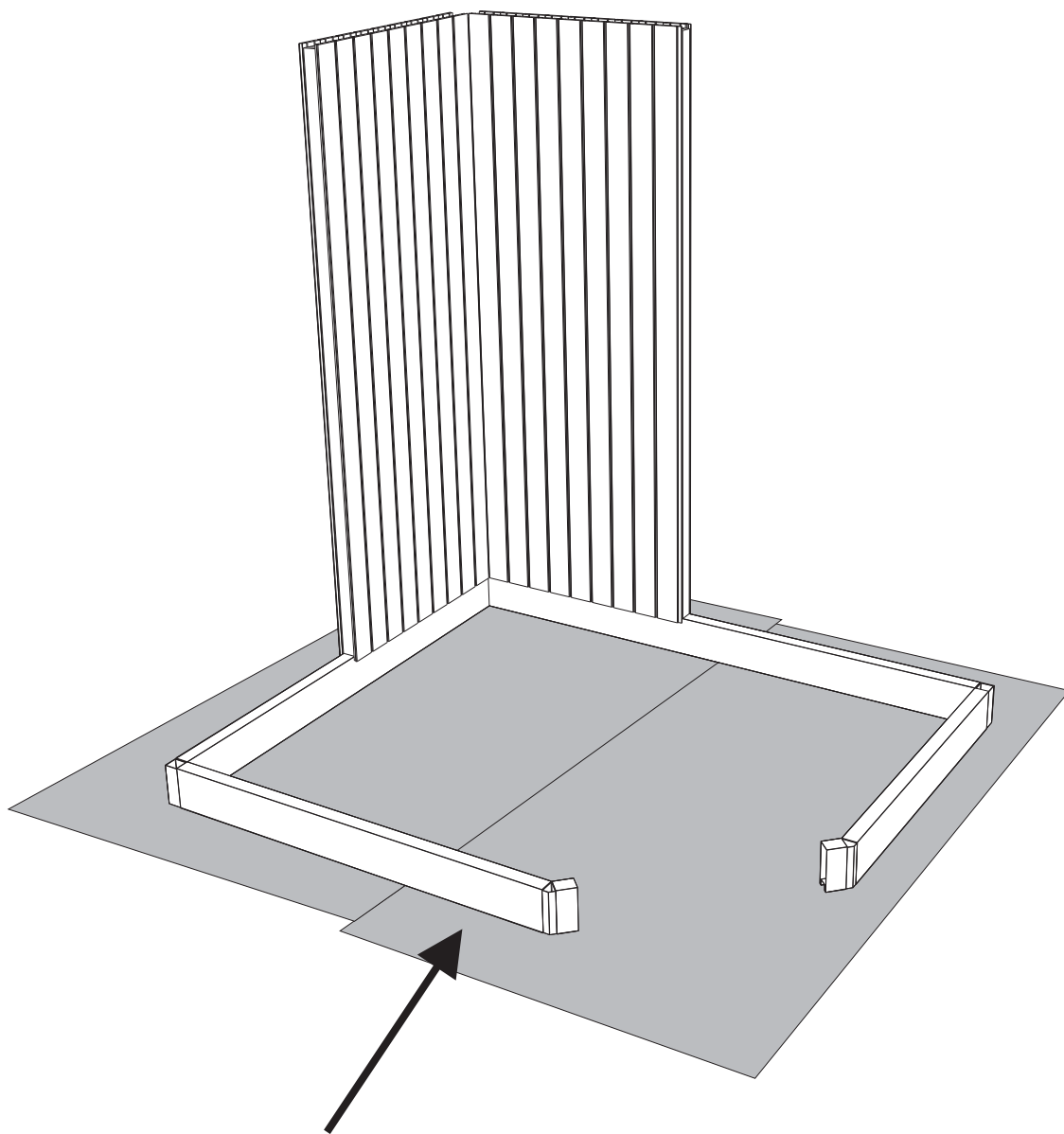

#### Rumsemballage

Använd som skydd på golvet vid montering av rummet.

#### Room packaging

Use as a protection on the floor during assembly of the room.

#### Opakowanie sauny

Można wykorzystać jako ochronę podłogi podczas montażu sauny.

# Tips! Tip! Porada!

Använd  
medföljande  
tråklossar som  
distanser mot  
befintlig vägg.

Use the supplied  
wooden blocks  
as spacers  
against the  
existing walls.

Elementy  
drewniane  
dostarczone w  
saunie można  
wykorzystać jako  
dystanse od ściany  
pomieszczenia.

P11

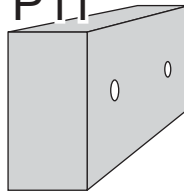

50mm



Ø 2

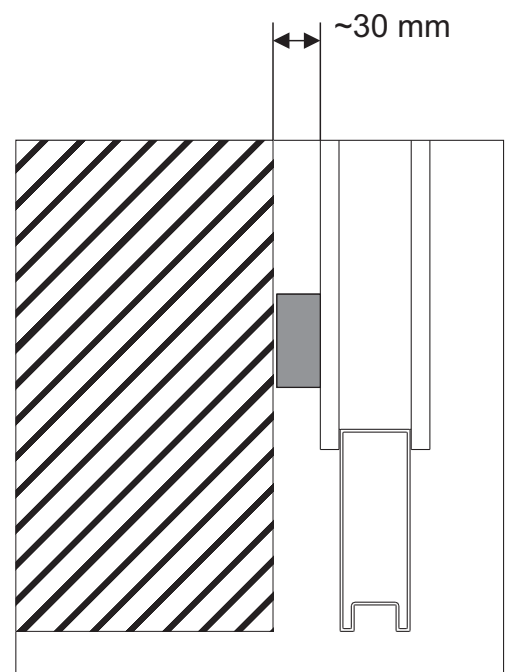
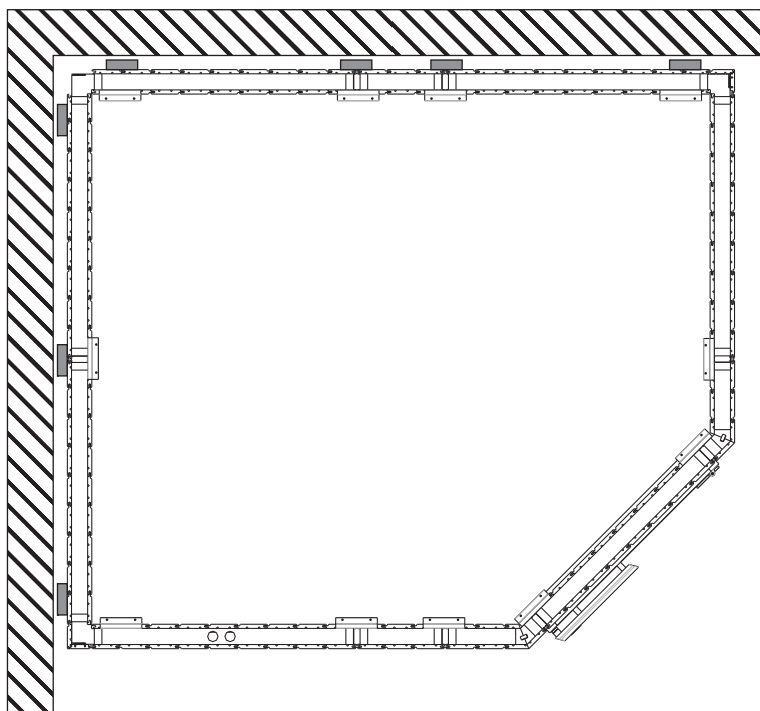
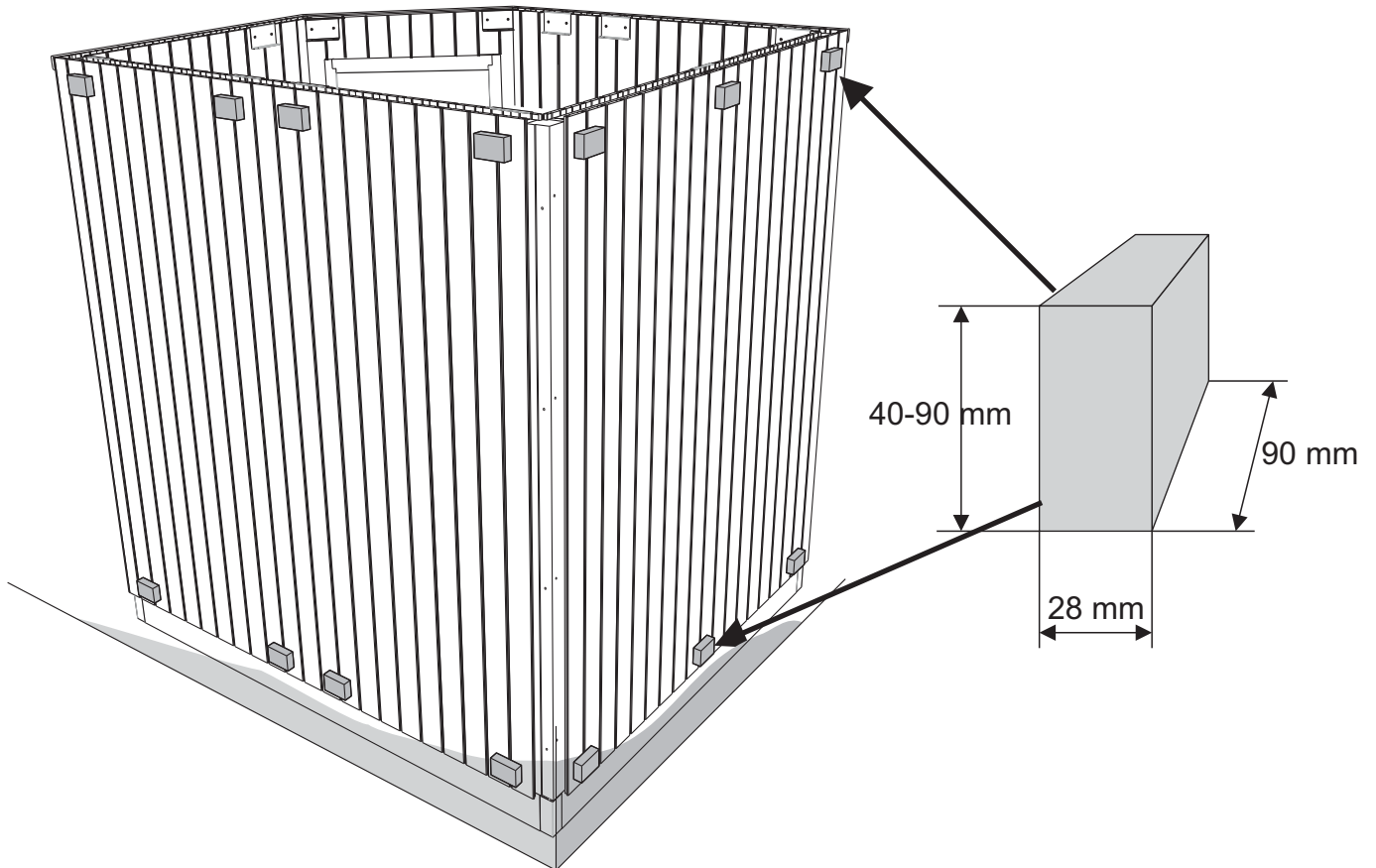

1A

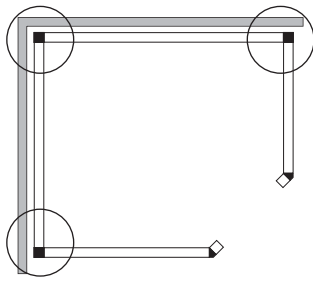

P1

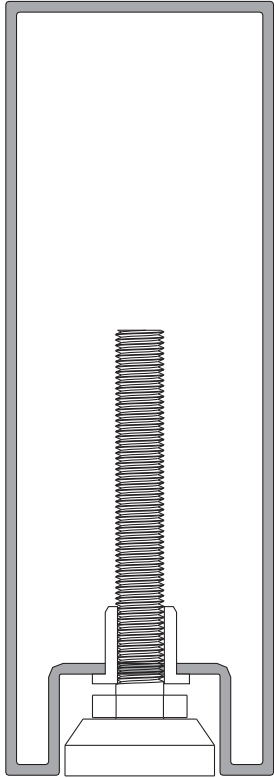

VIKTIGT!!  
IMPORTANT!!  
WAŻNE!!!

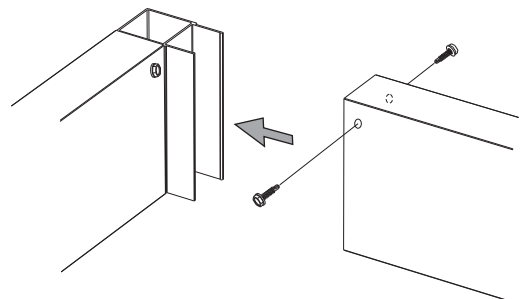
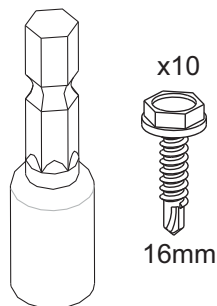
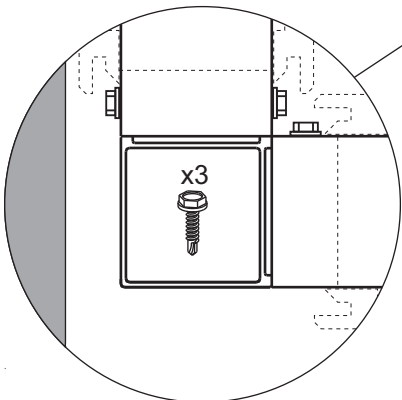
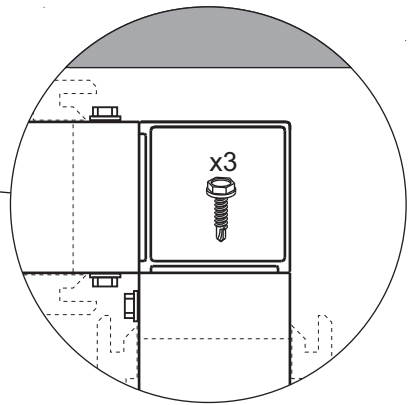
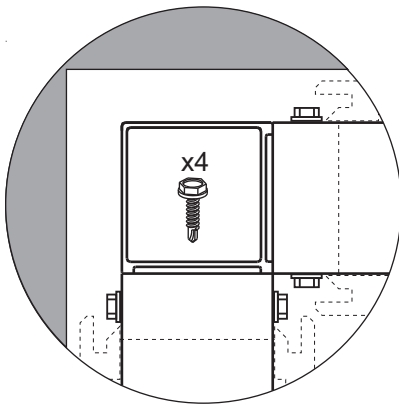
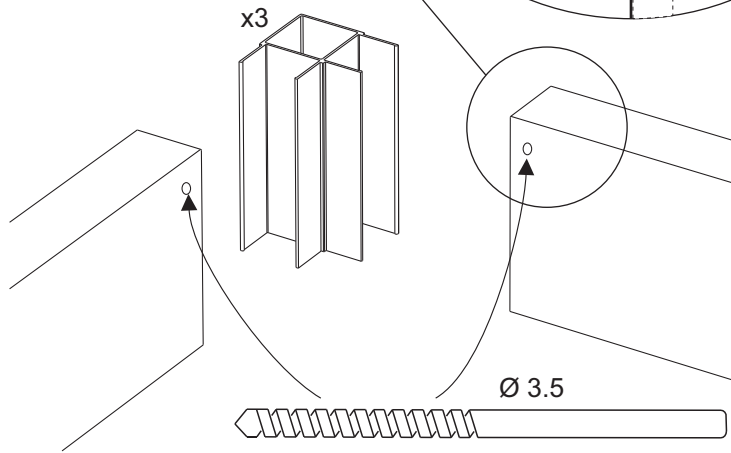
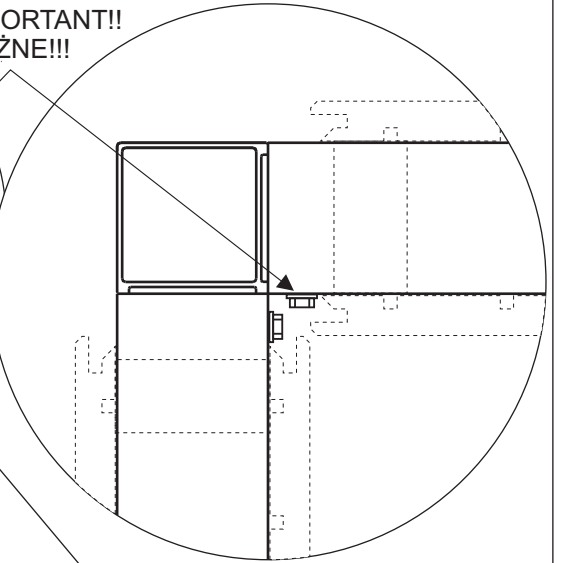
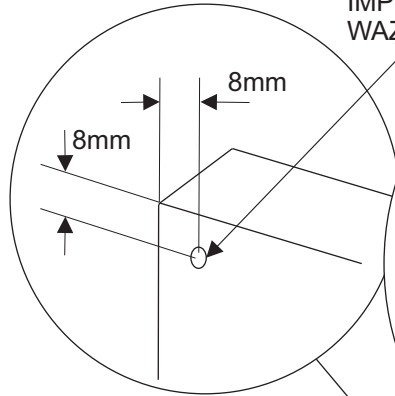

# 1B

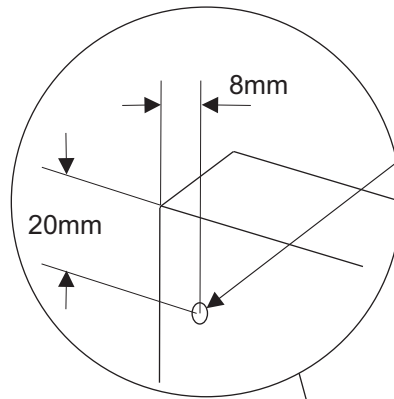
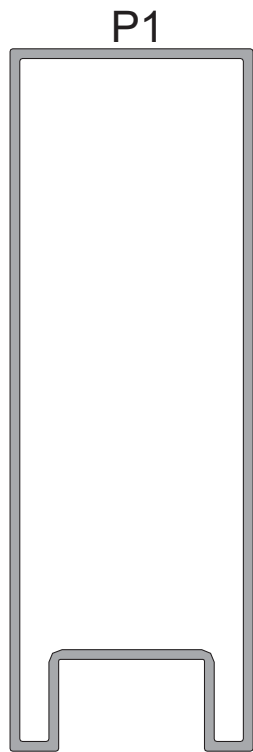
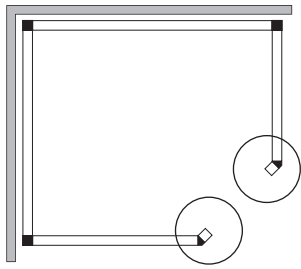

VIKTIGT!!  
IMPORTANT!!  
WAŻNE!!!

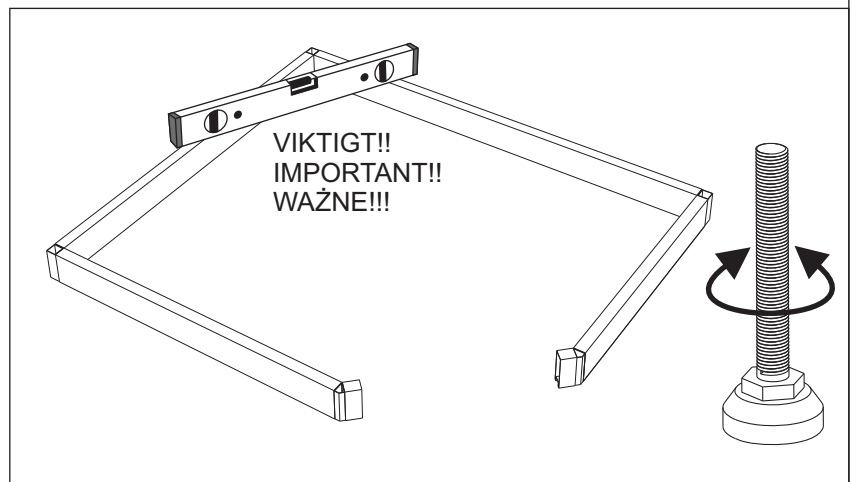
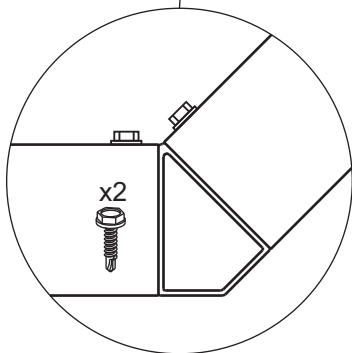
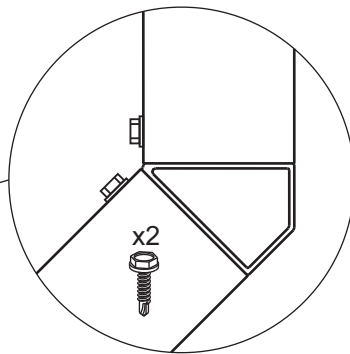
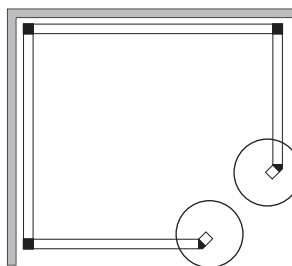
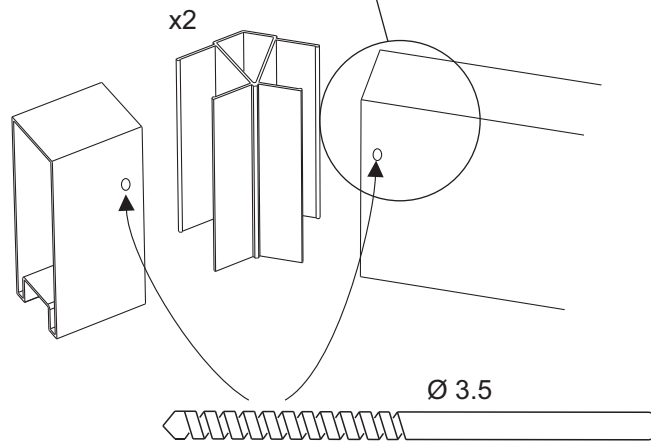

2

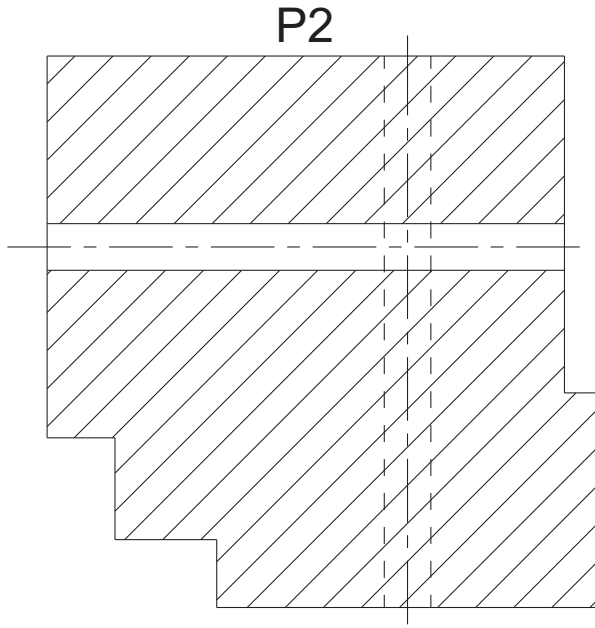

P2x3

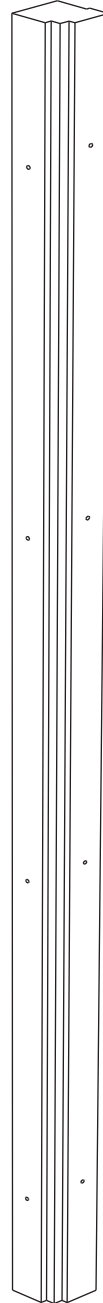

P2-A  
P2-B  
P2-C

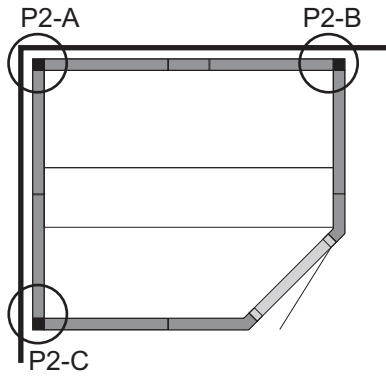

3

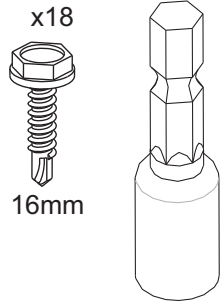
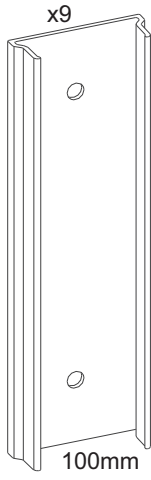

P2x2

P2-B  
P2-C

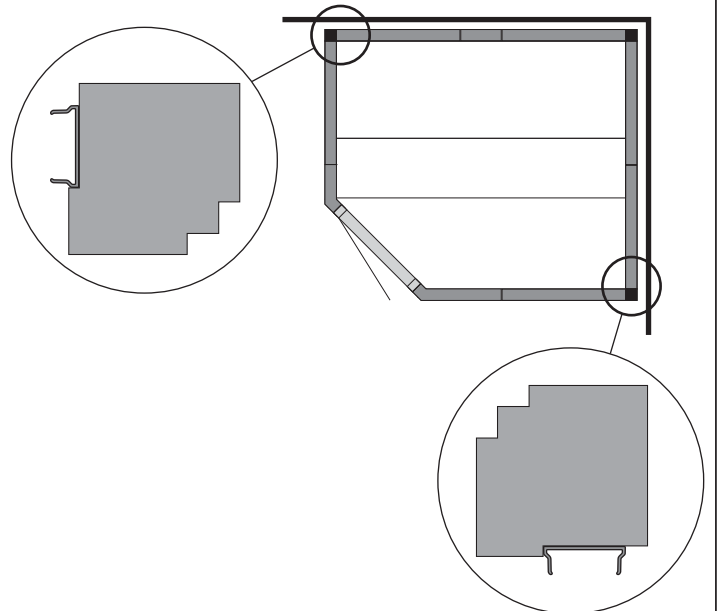
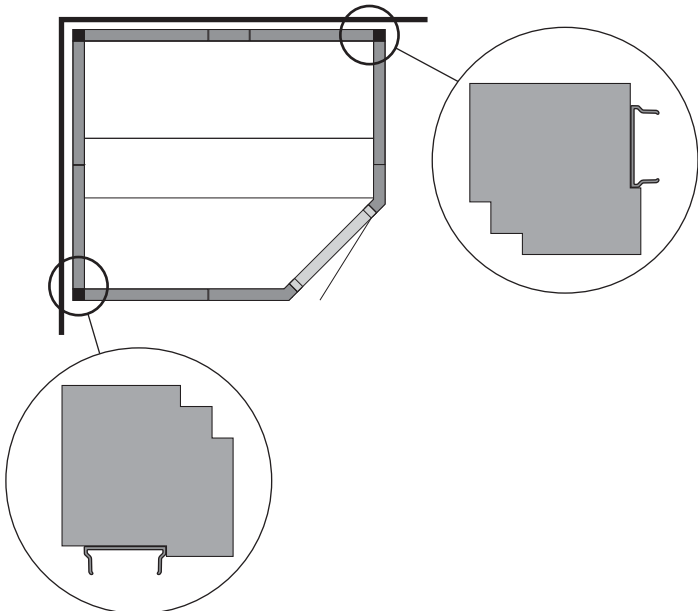
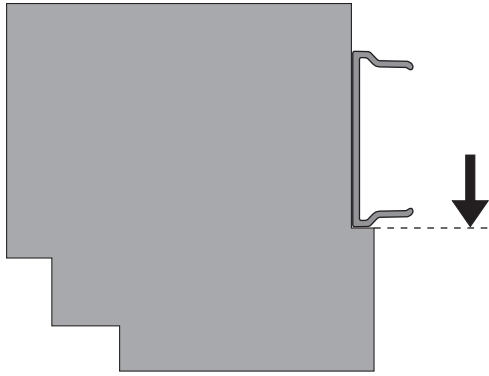
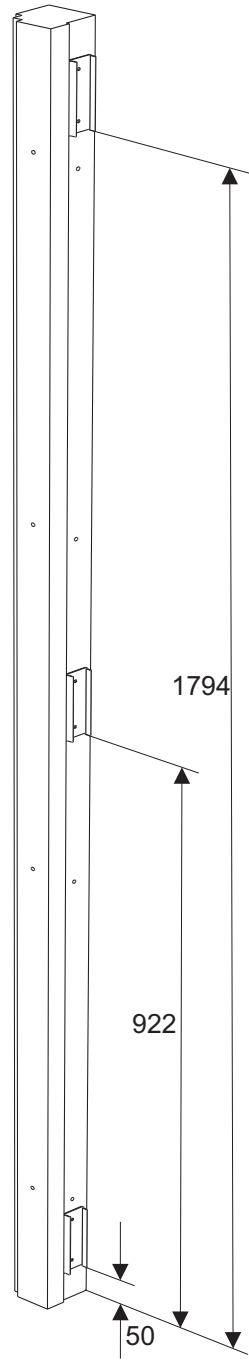



4

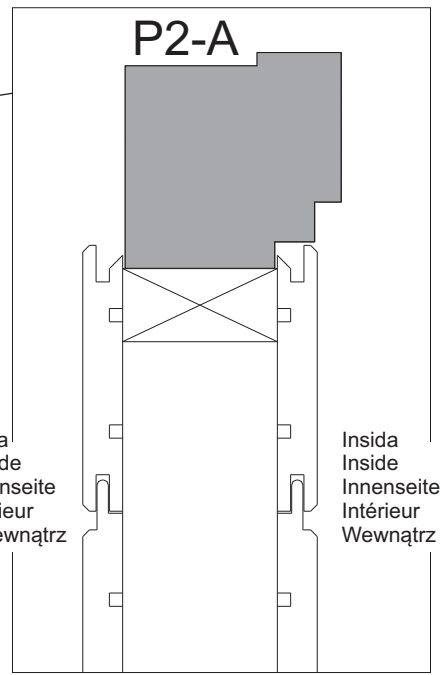
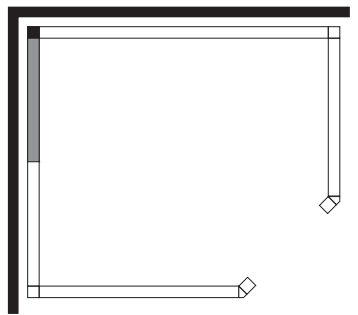
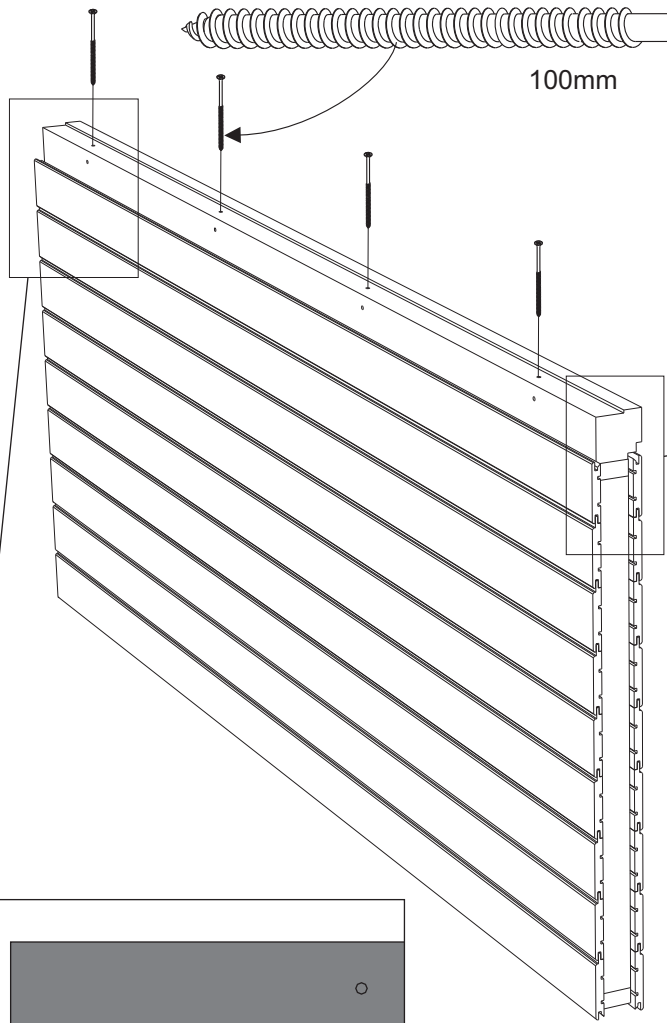
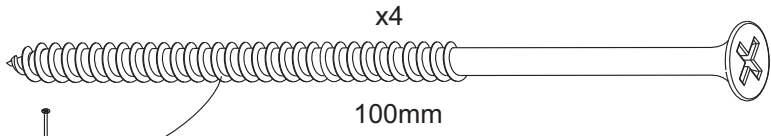

Utsida  
Outside  
Außenseite  
Extérieur  
Na zewnątrz

Insida  
Inside  
Innenseite  
Intérieur  
Wewnątrz

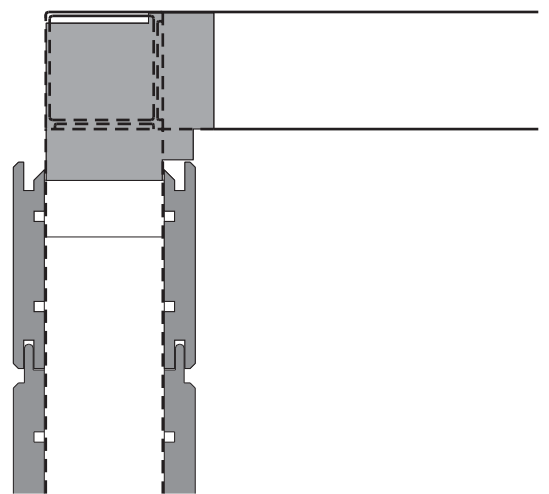
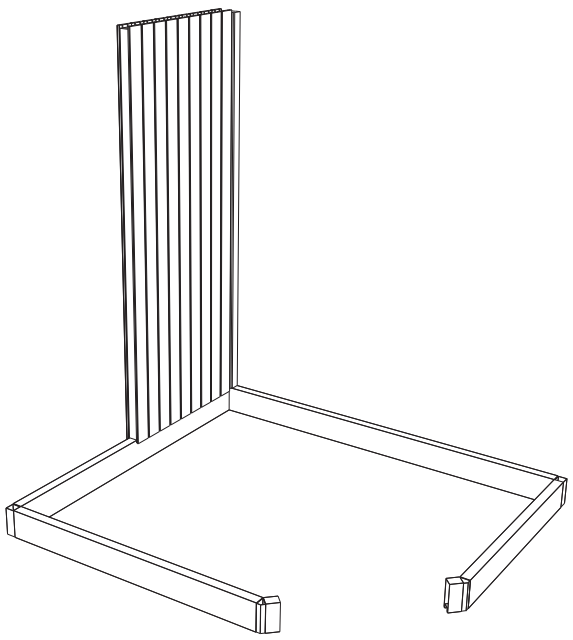
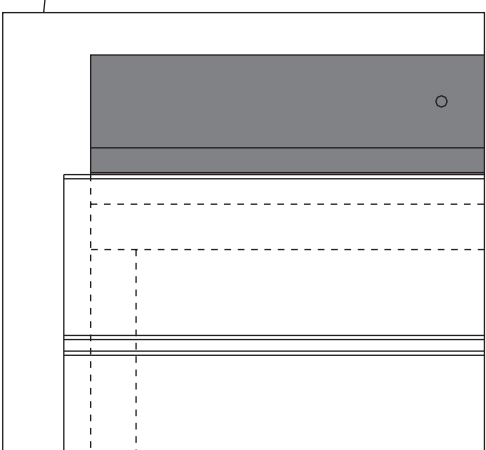

5

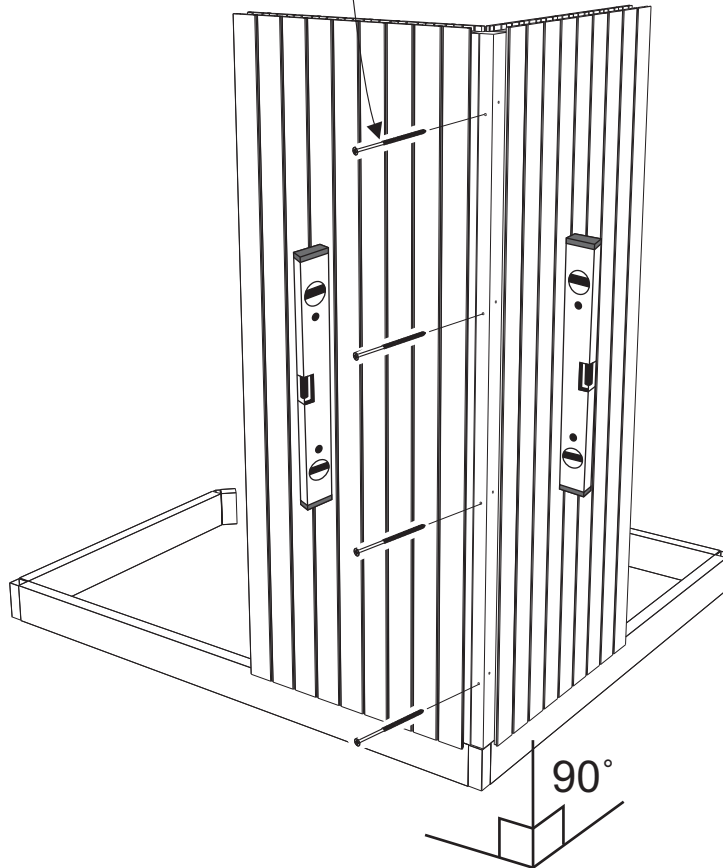
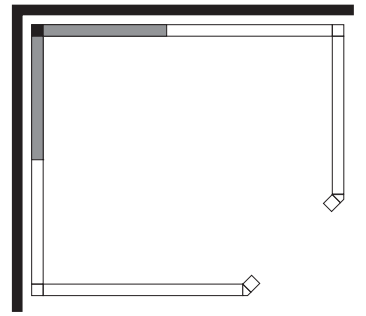
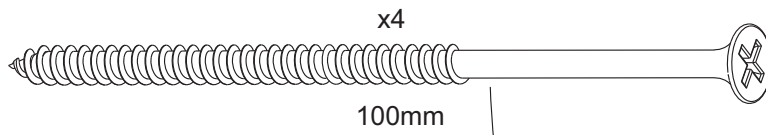

OBS! Det är viktigt att väggarna är i jämnhöjd i hörnen.

N.B.! It's important that the walls are on the same level in the corners.

UWAGA! Ważne jest, aby narożniki ścianek znajdowały się na tym samym poziomie.

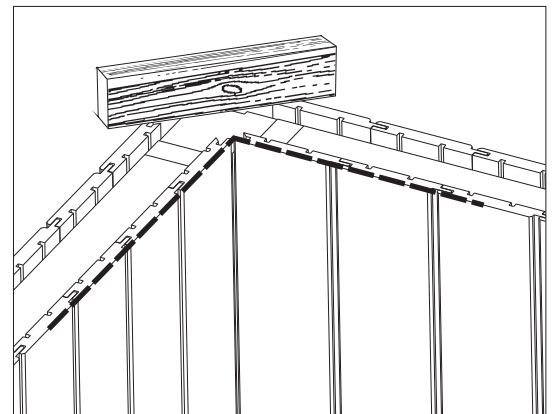
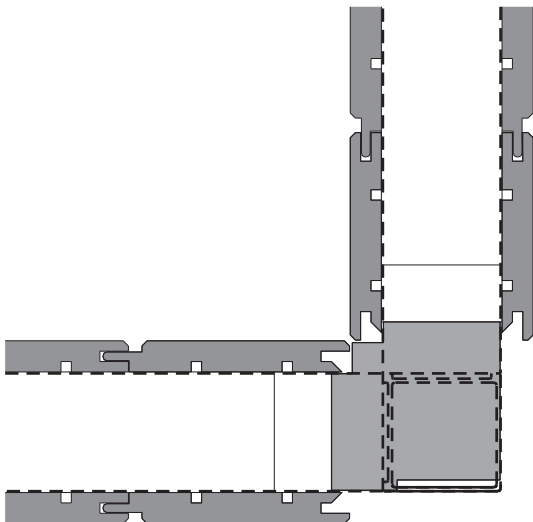

6

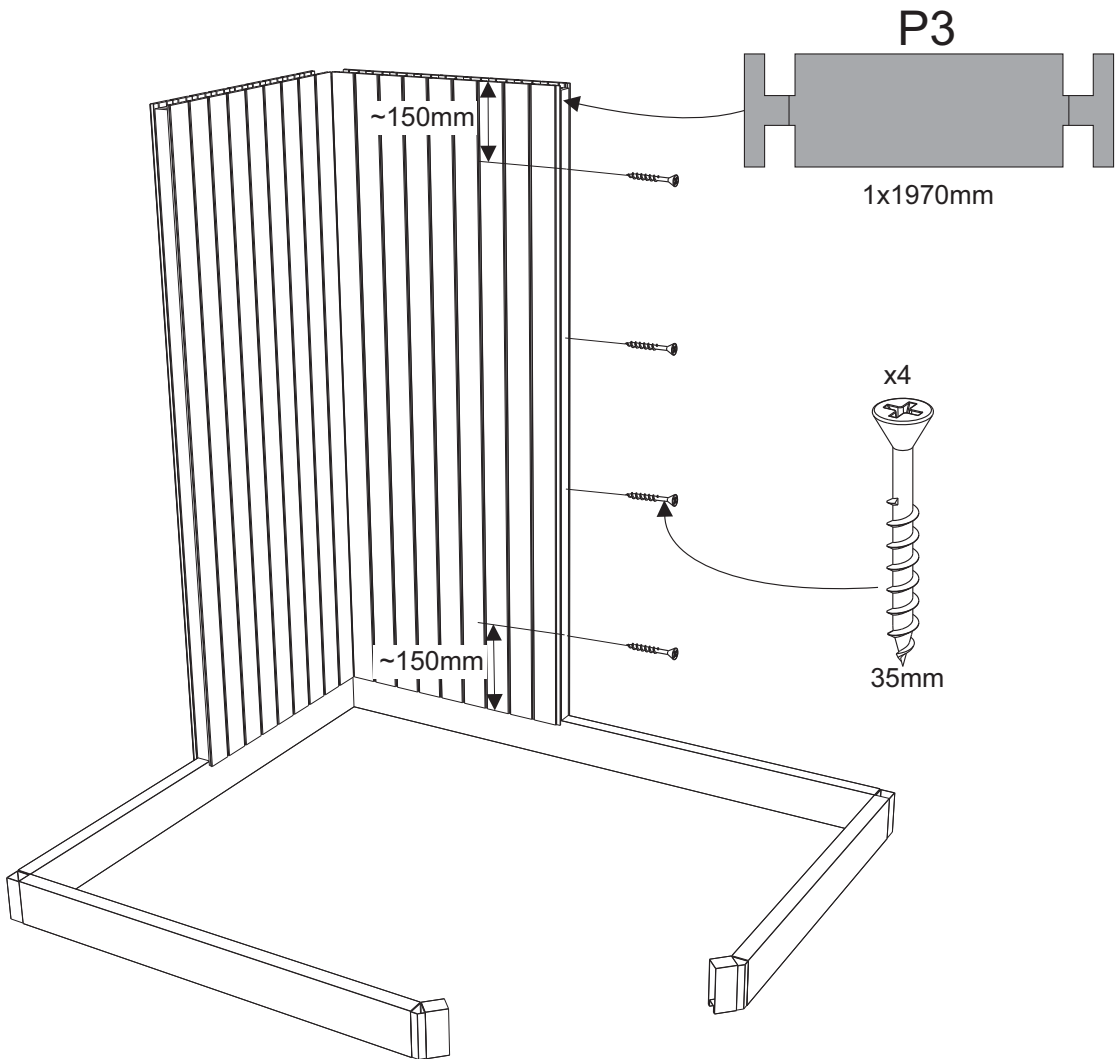
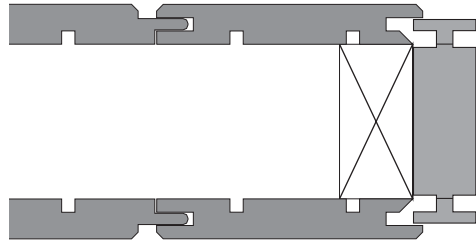
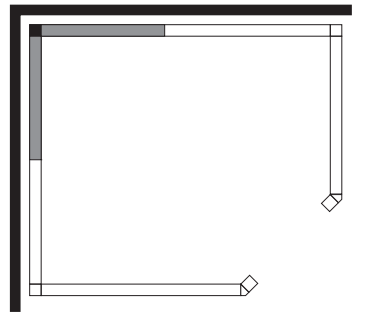

7

Kant i kant  
Flush fitting  
Kantenbündig  
Bord à bord  
Dokładnie wyrównać

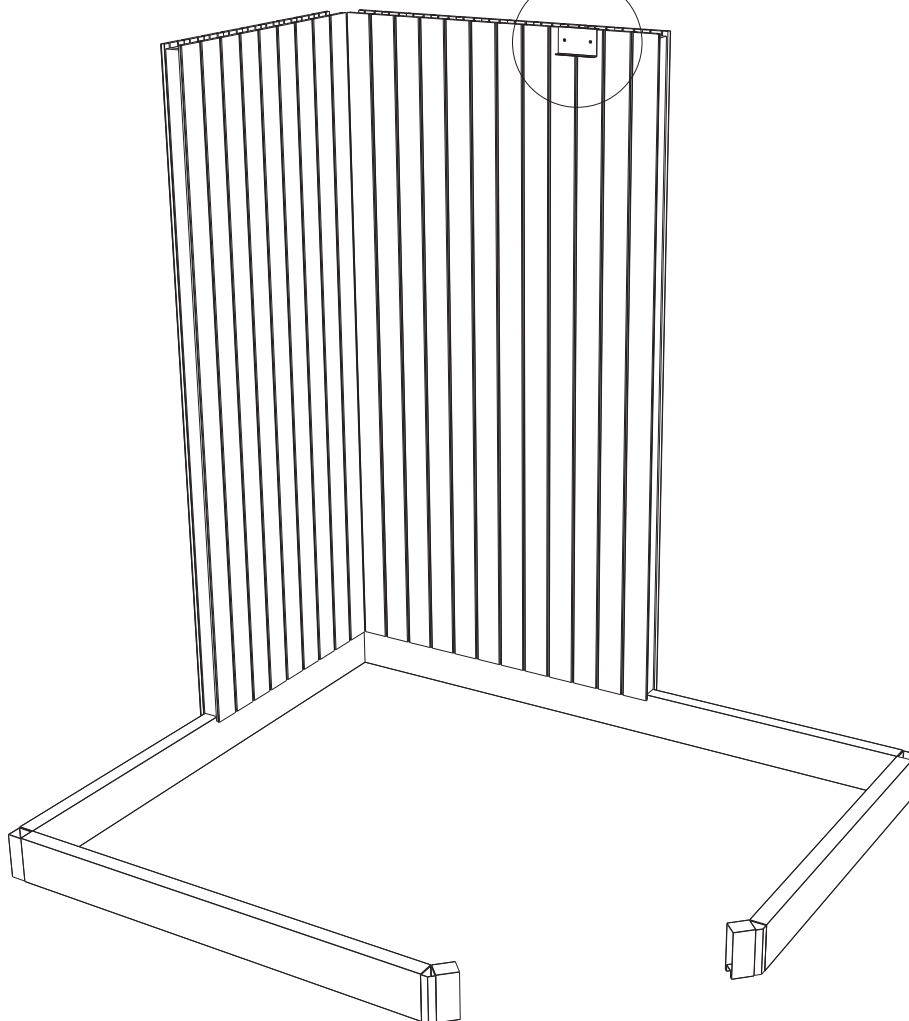
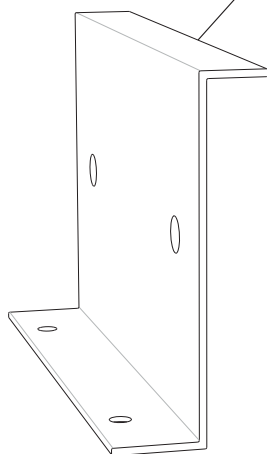
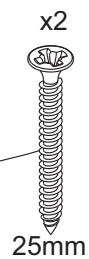
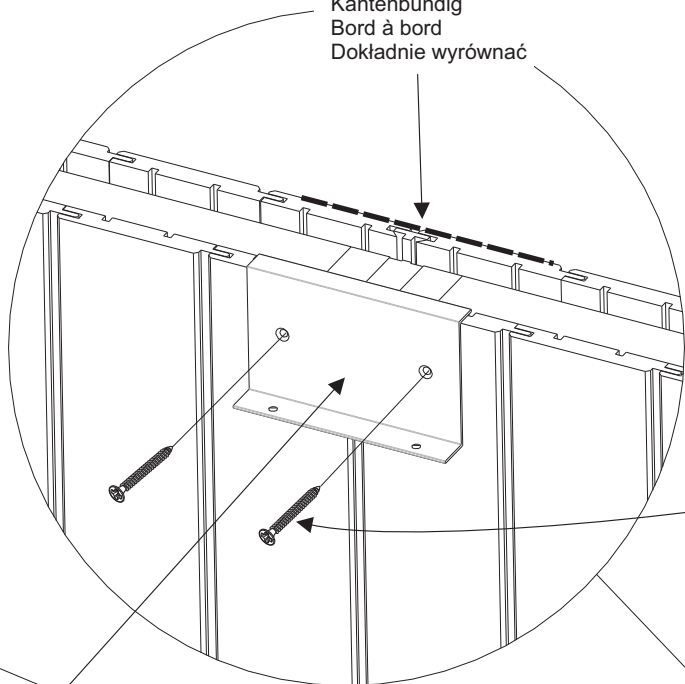
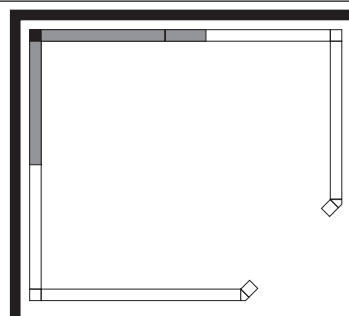

8

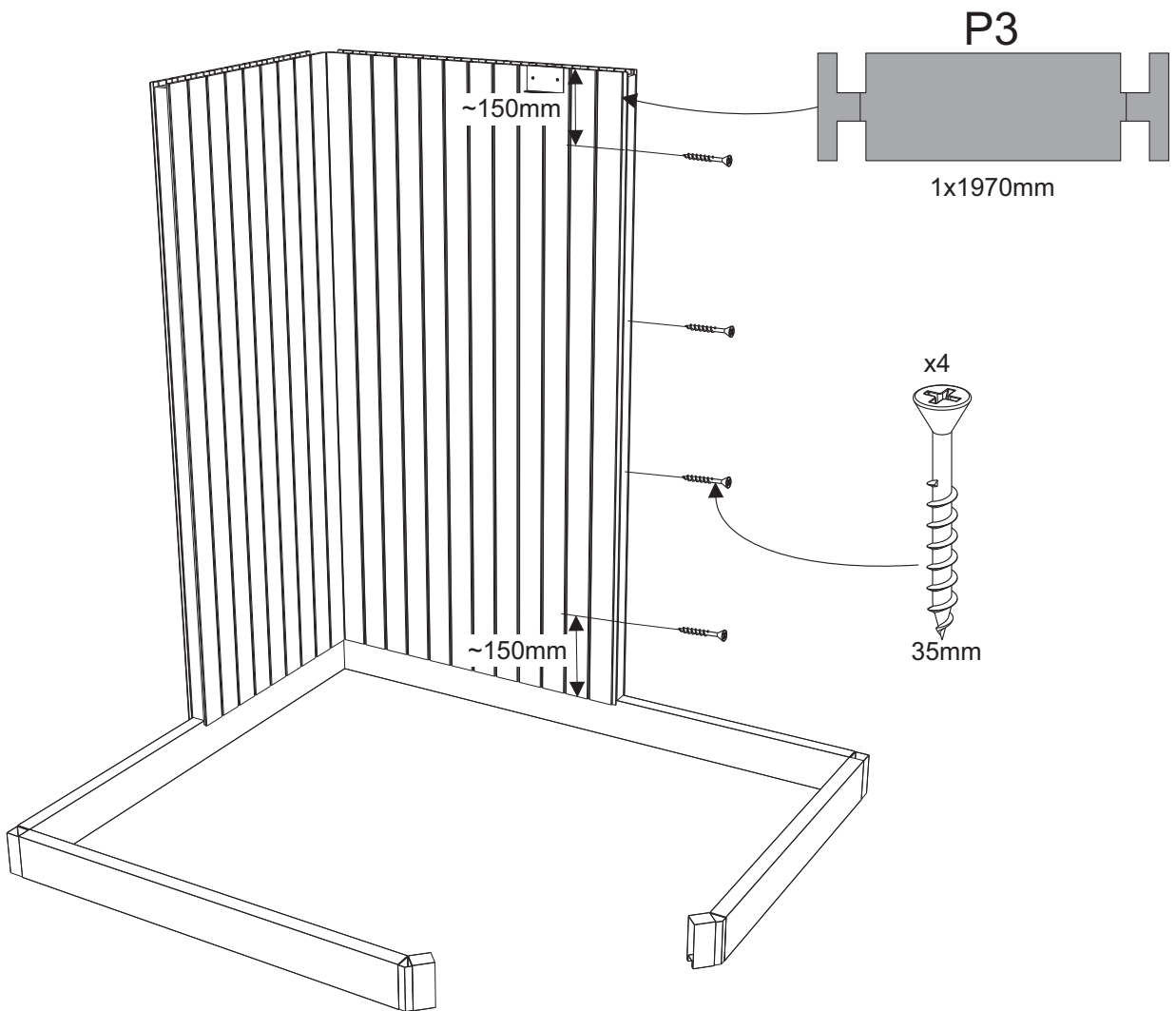
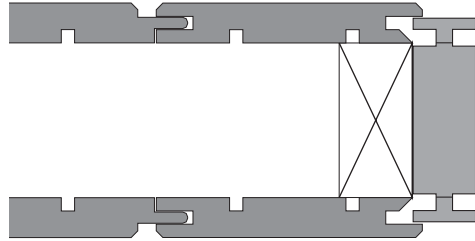
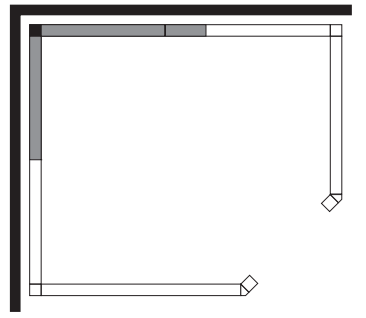

9

Kant i kant  
Flush fitting  
Kantenbündig  
Bord à bord  
Dokładnie wyrównać

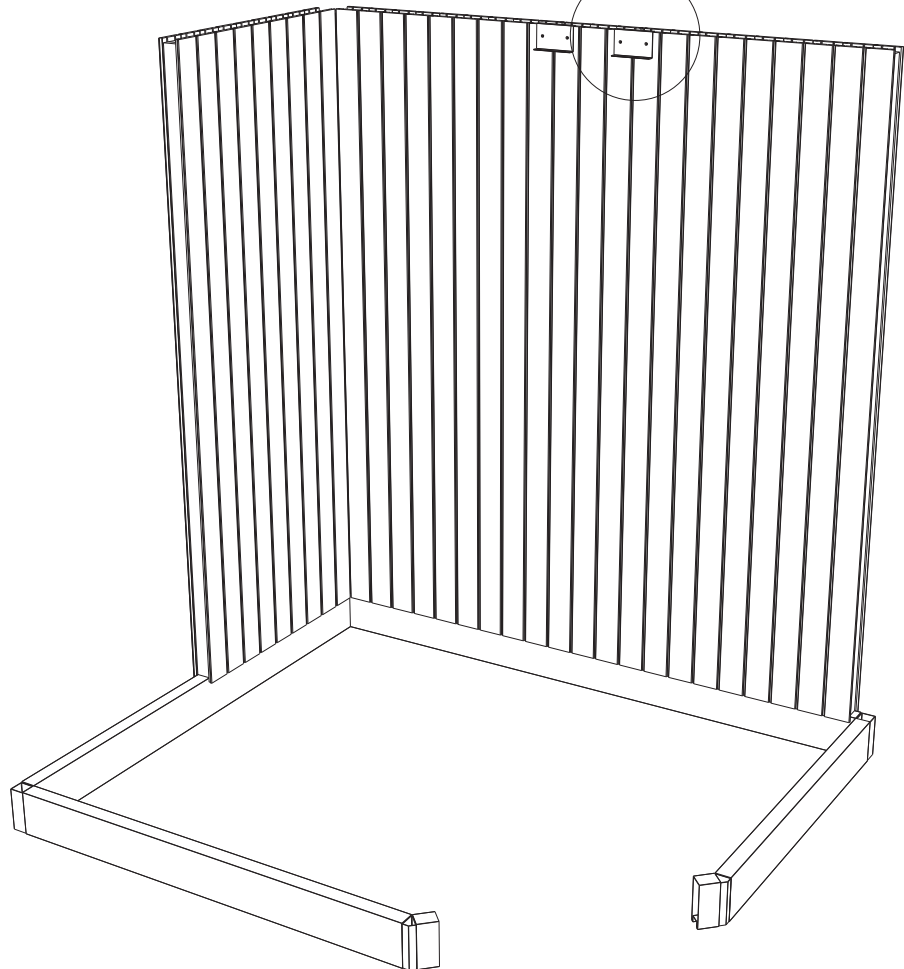
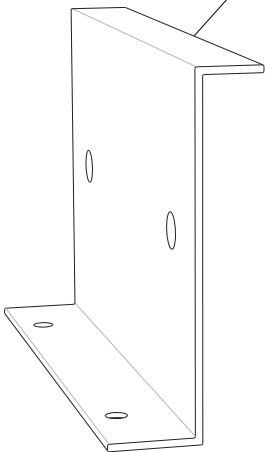
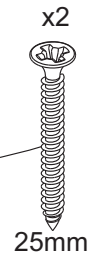
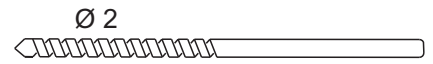
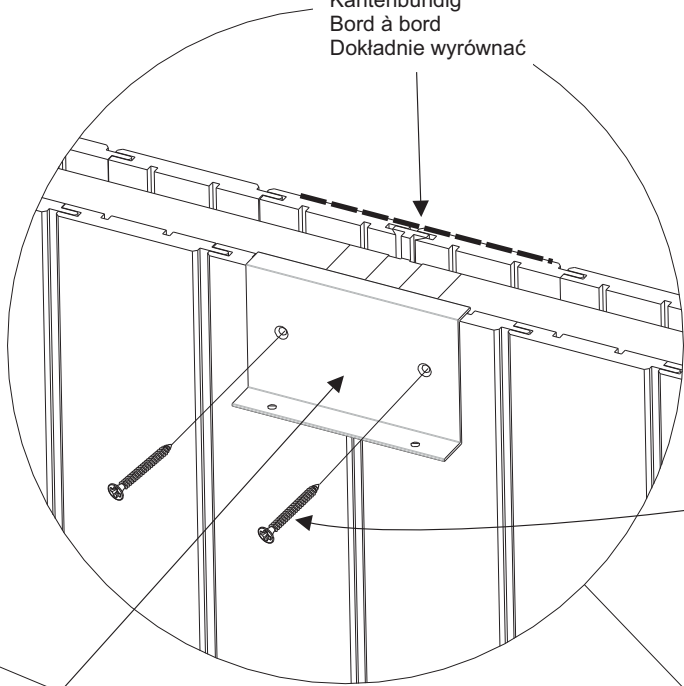
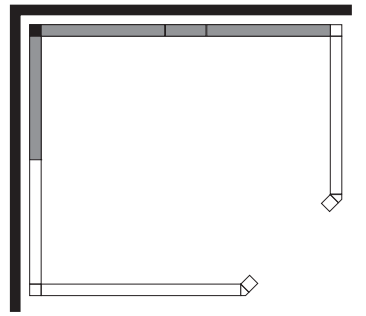

10

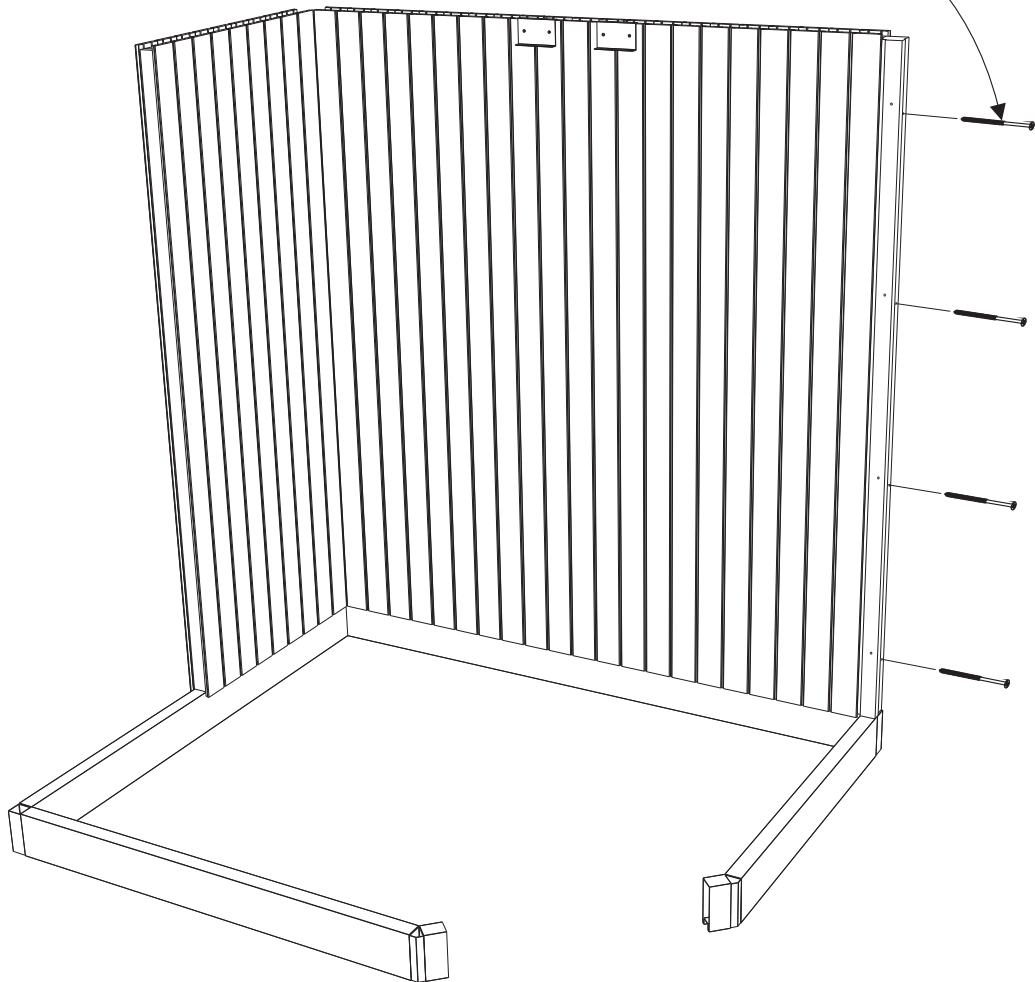
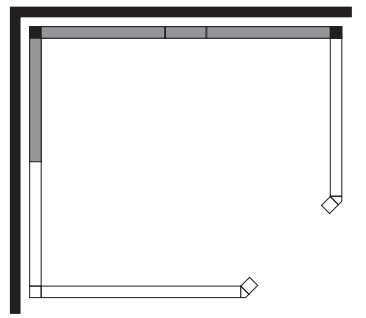
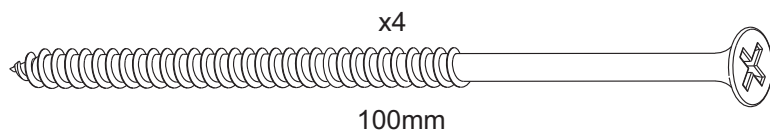

Utsida  
Outside  
Außenseite  
Extérieur  
Na zewnątrz

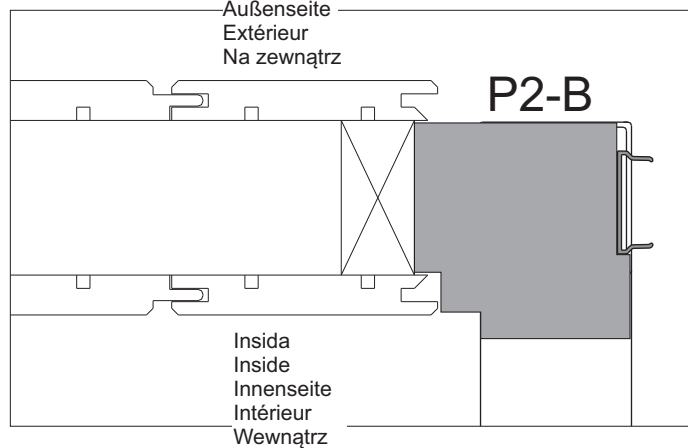

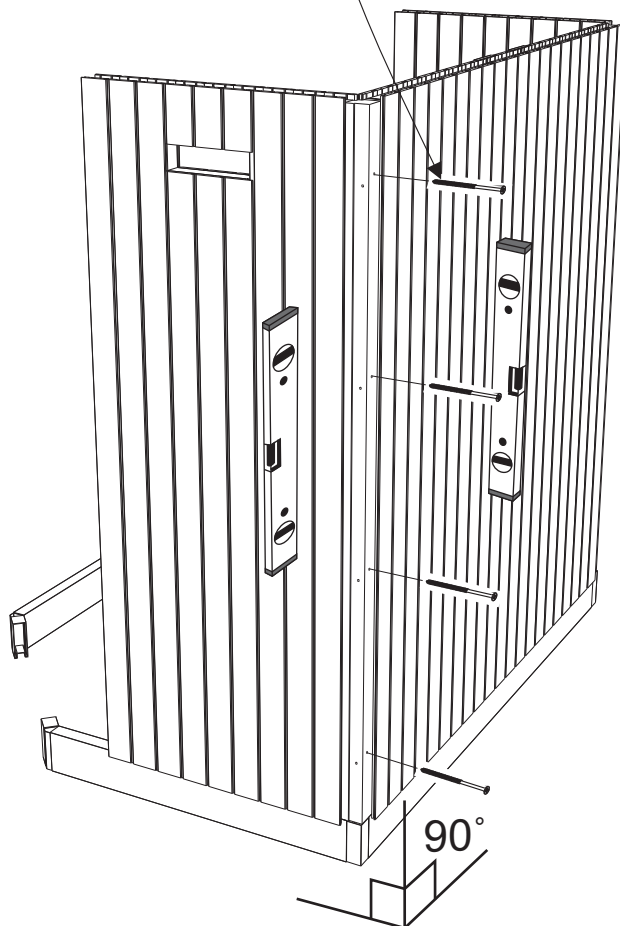
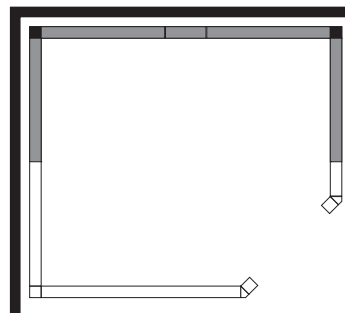
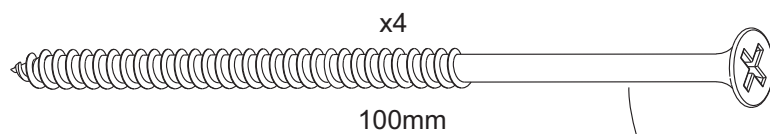

OBS! Det är viktigt att väggarna är i jämnhöjd i hörnen.

N.B.! It's important that the walls are on the same level in the corners.

UWAGA! Ważne jest, aby narożniki ścianek znajdowały się na tym samym poziomie.

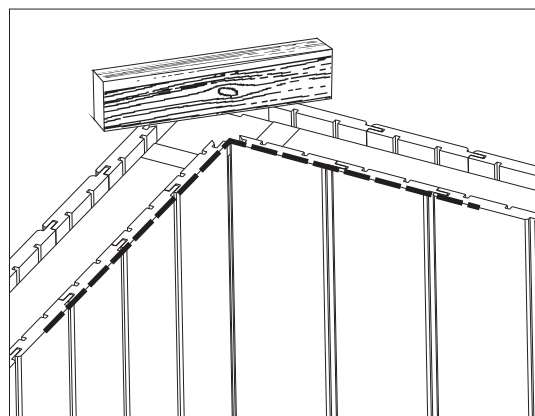
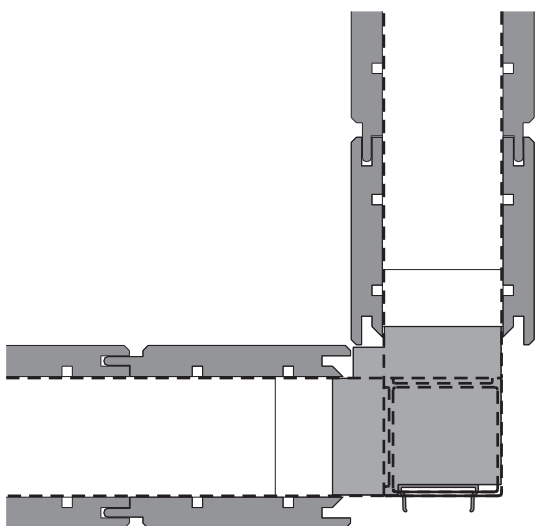



12

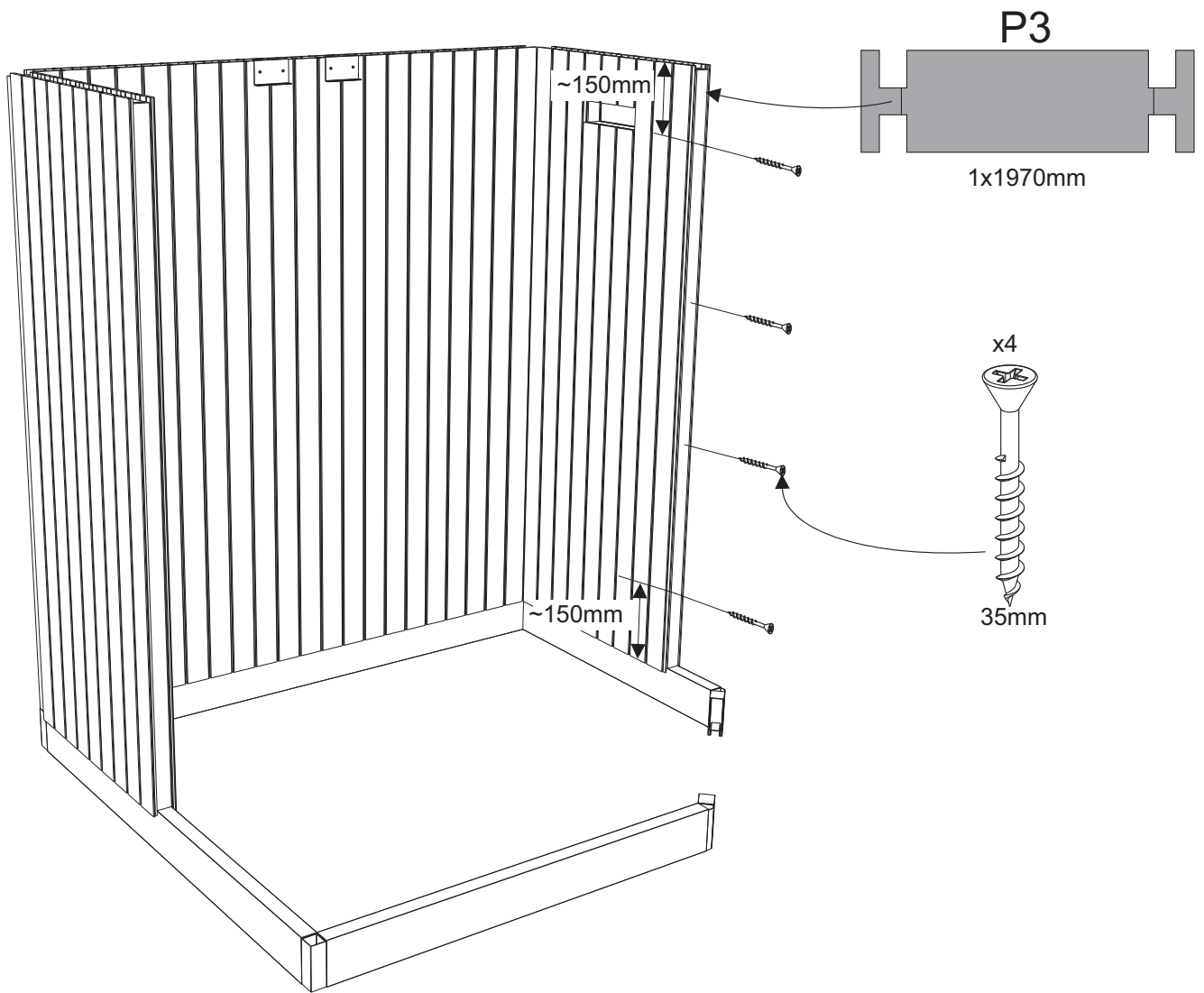
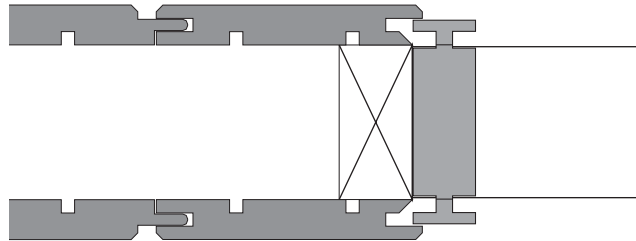
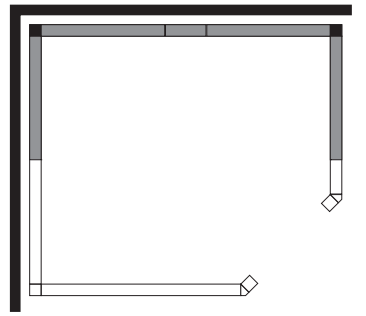

13

Kant i kant  
Flush fitting  
Kantenbündig  
Bord à bord  
Dokładnie wyrównać

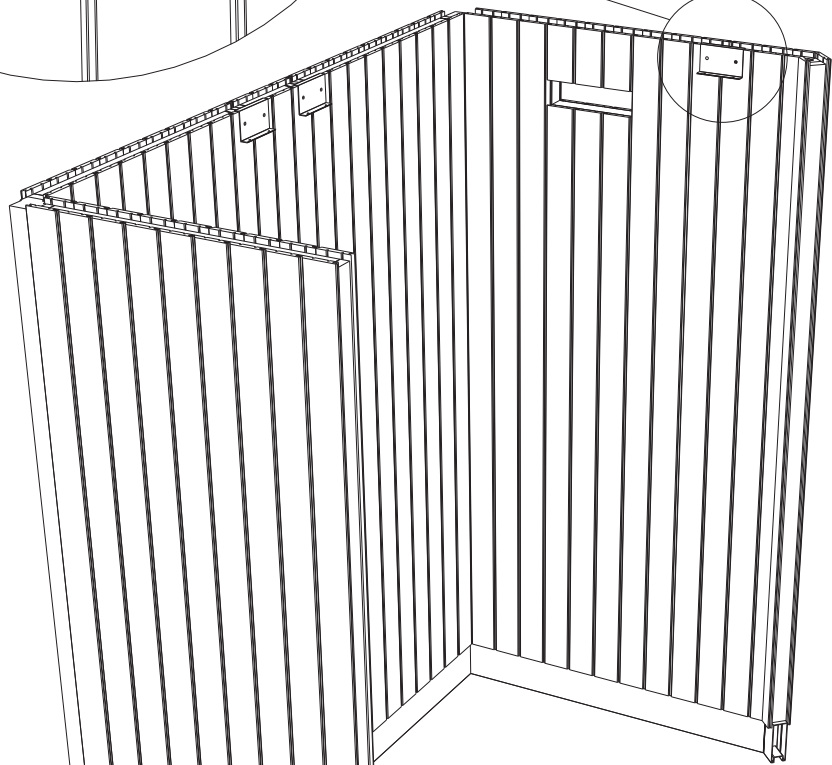
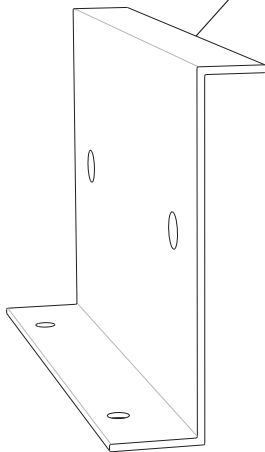
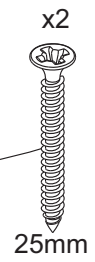
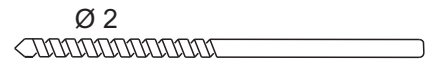
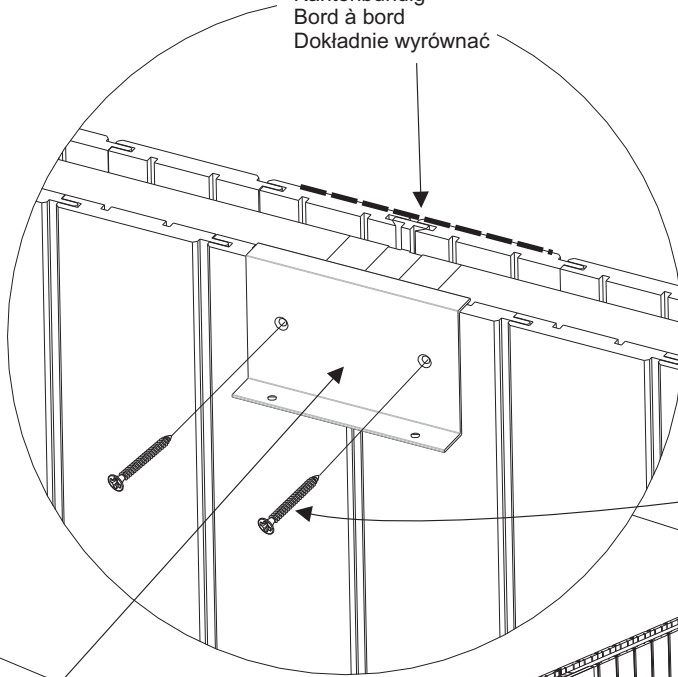
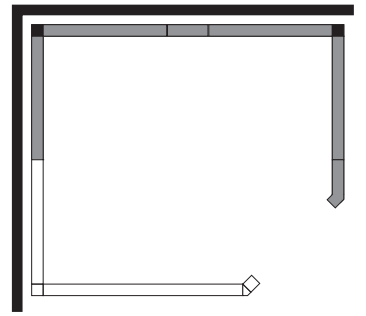

14

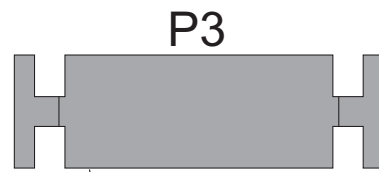
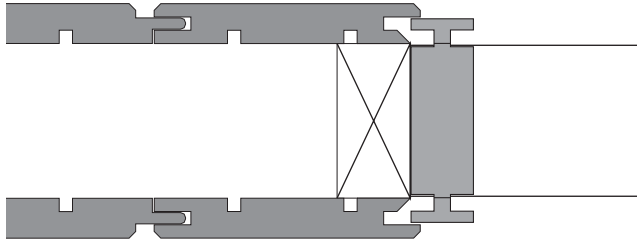
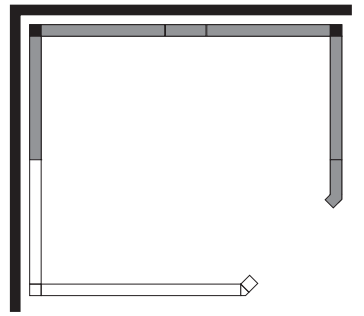

1x1970mm

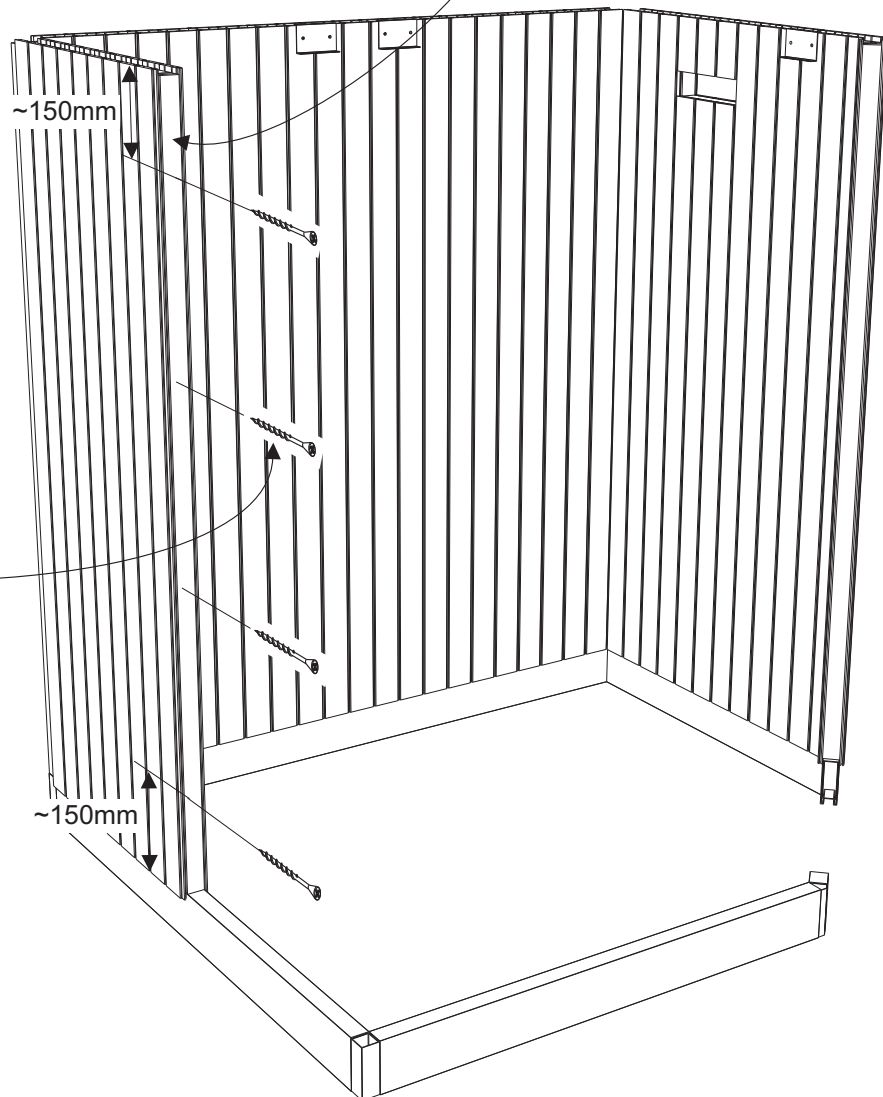
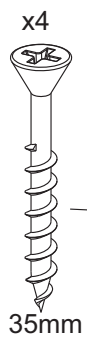

15

Kant i kant  
Flush fitting  
Kantenbündig  
Bord à bord  
Dokładnie wyrównać

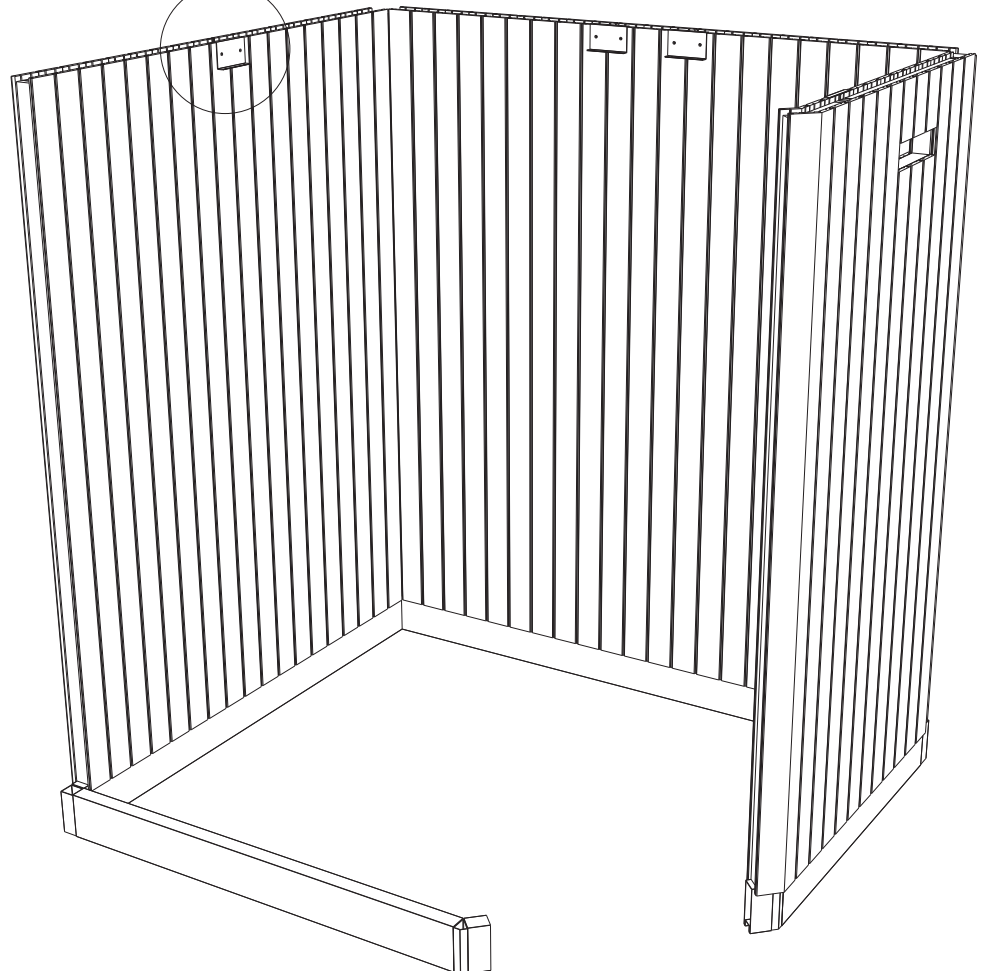
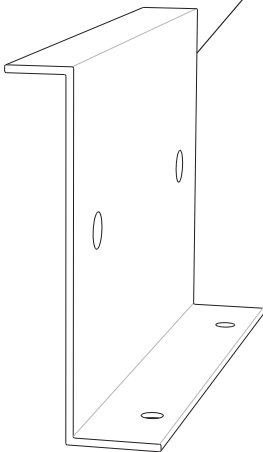
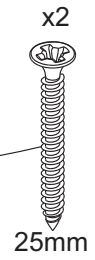
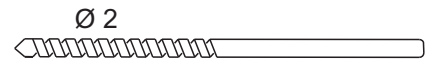
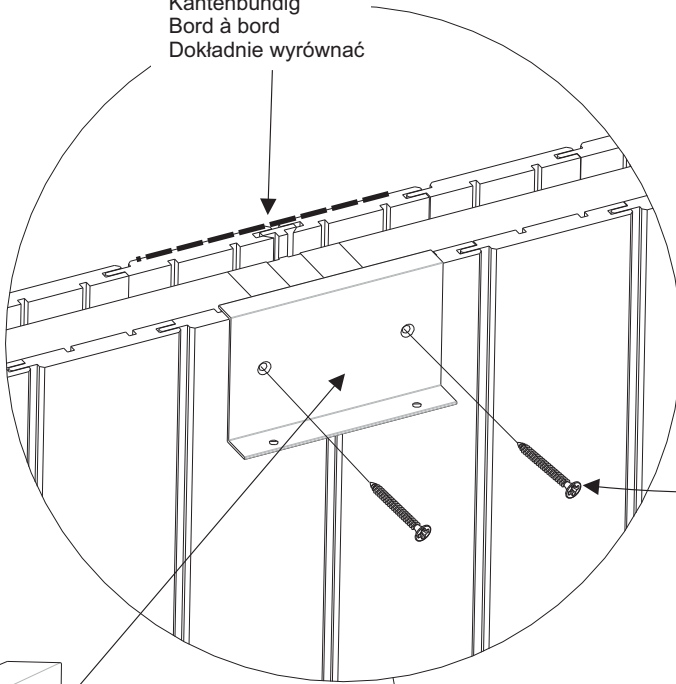
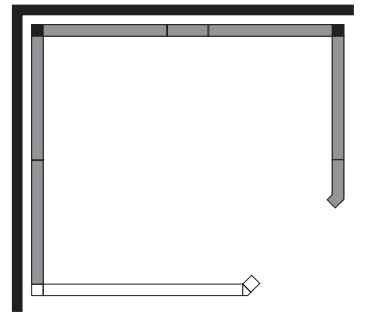

16

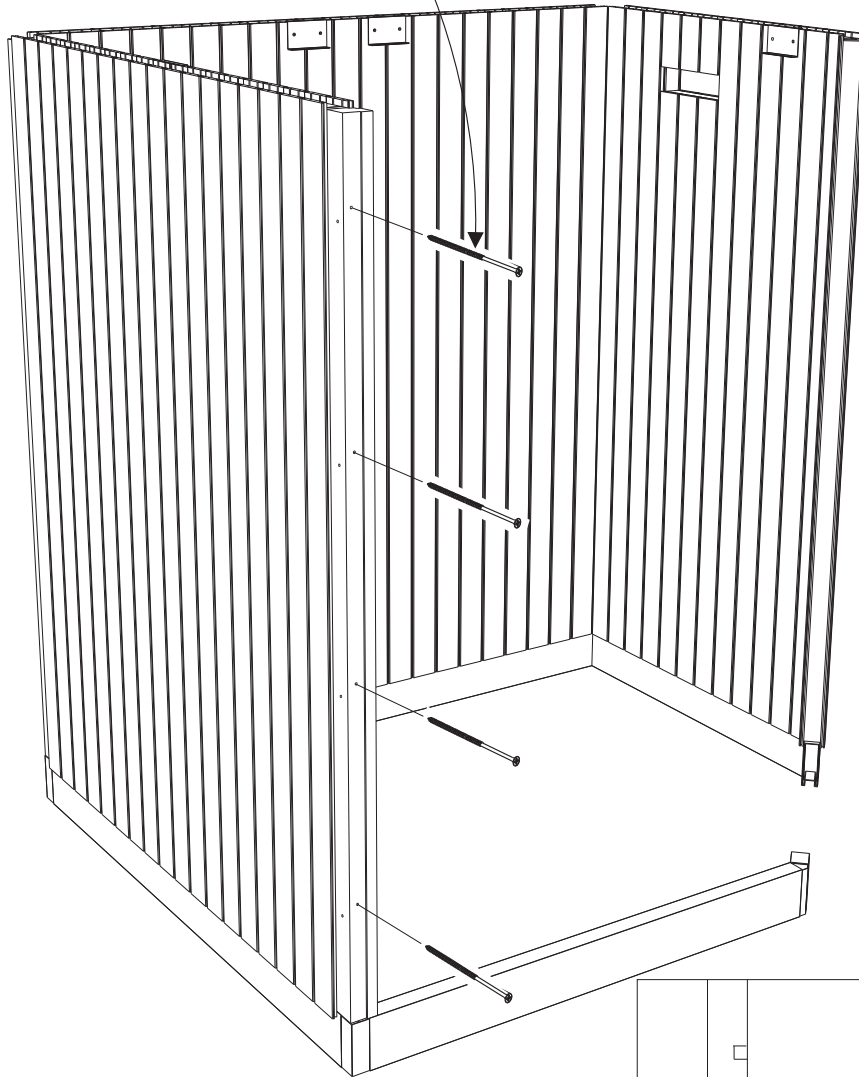
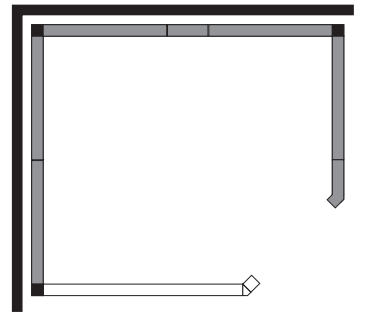
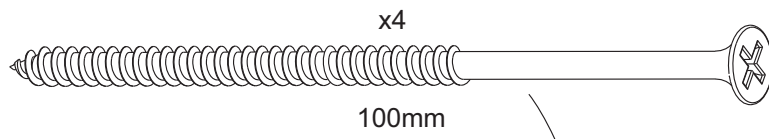

Utsida  
Outside  
Außenseite  
Extérieur  
Na zewnątrz

Insida  
Inside  
Innenseite  
Intérieur  
Wewnątrz

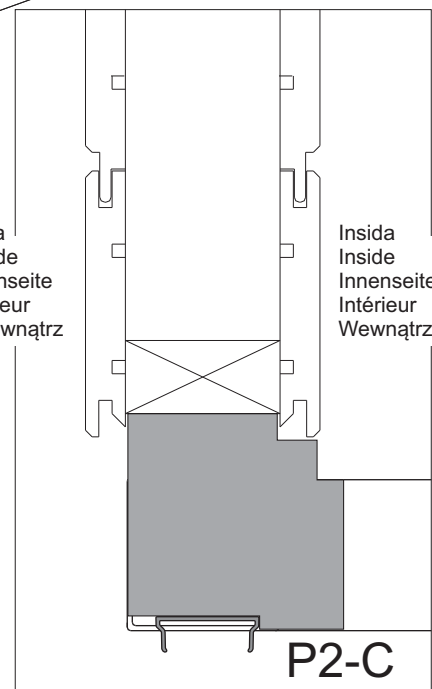

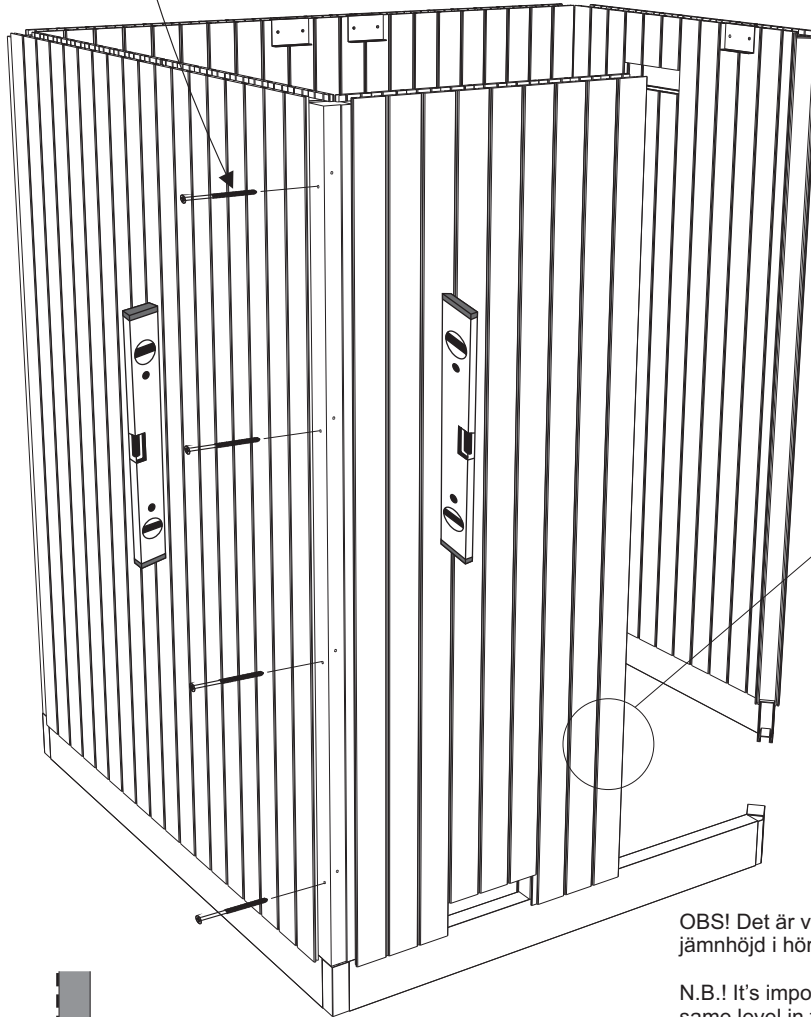
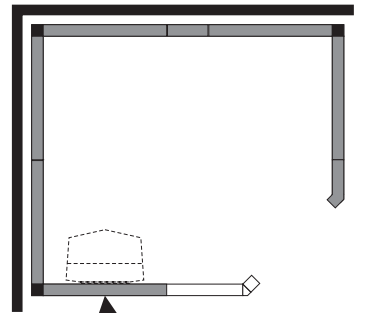
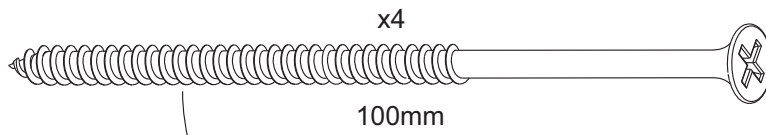

OBS! Insida/utsida  
 N.B.! Inside/outside  
 UWAGA! Wewnątrz/Na zewnątrz

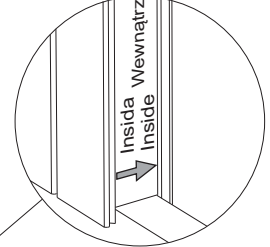

OBS! Det är viktigt att väggarna är i  
 jämnhöjd i hörnen.

N.B.! It's important that the walls are on the  
 same level in the corners.

UWAGA! Ważne jest, aby narożniki ścianek  
 znajdowały się na tym samym poziomie.

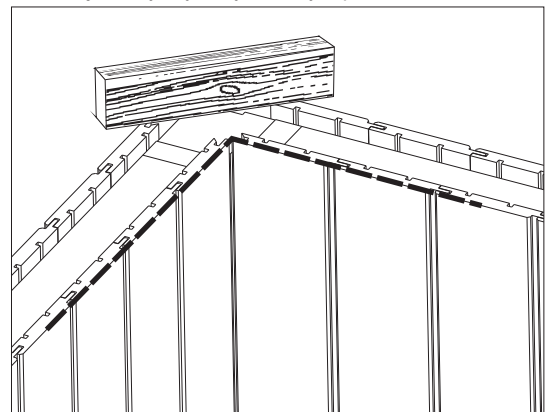
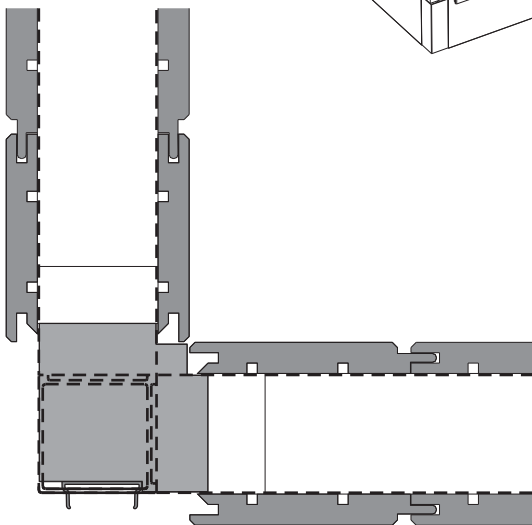

18

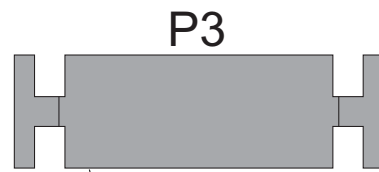
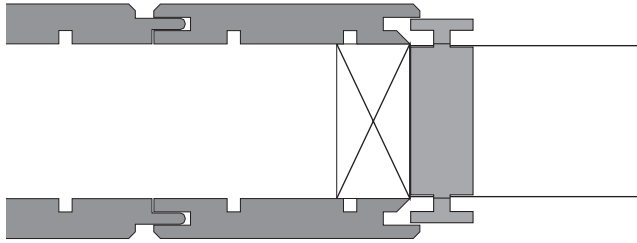
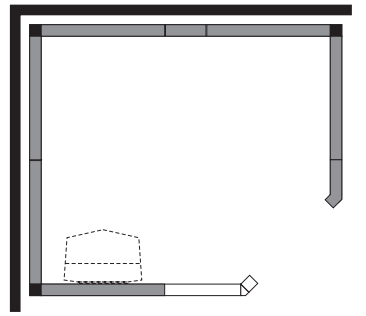

P3

1x1970mm

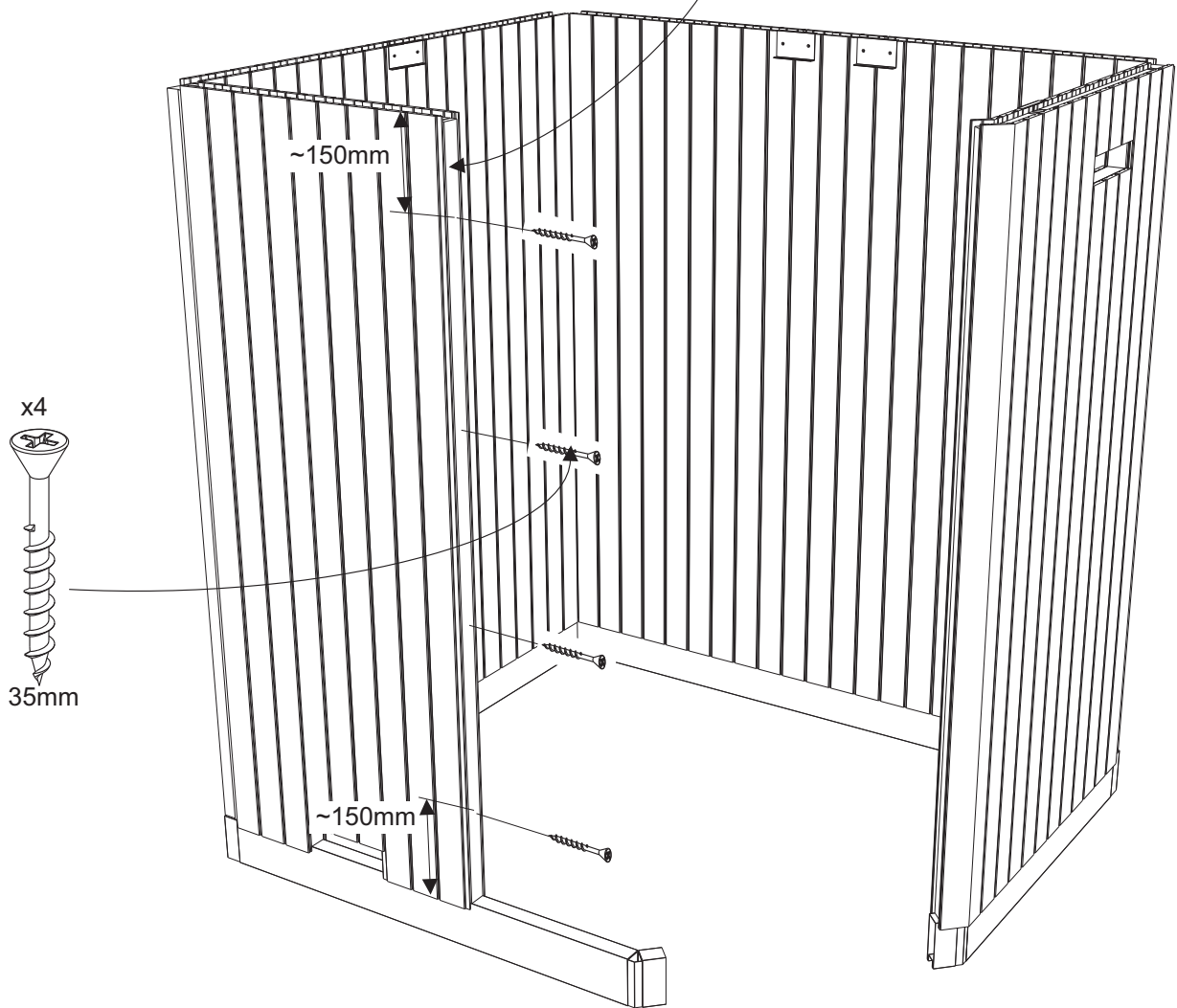

19

Kant i kant  
Flush fitting  
Kantenbündig  
Bord à bord  
Dokładnie wyrównać

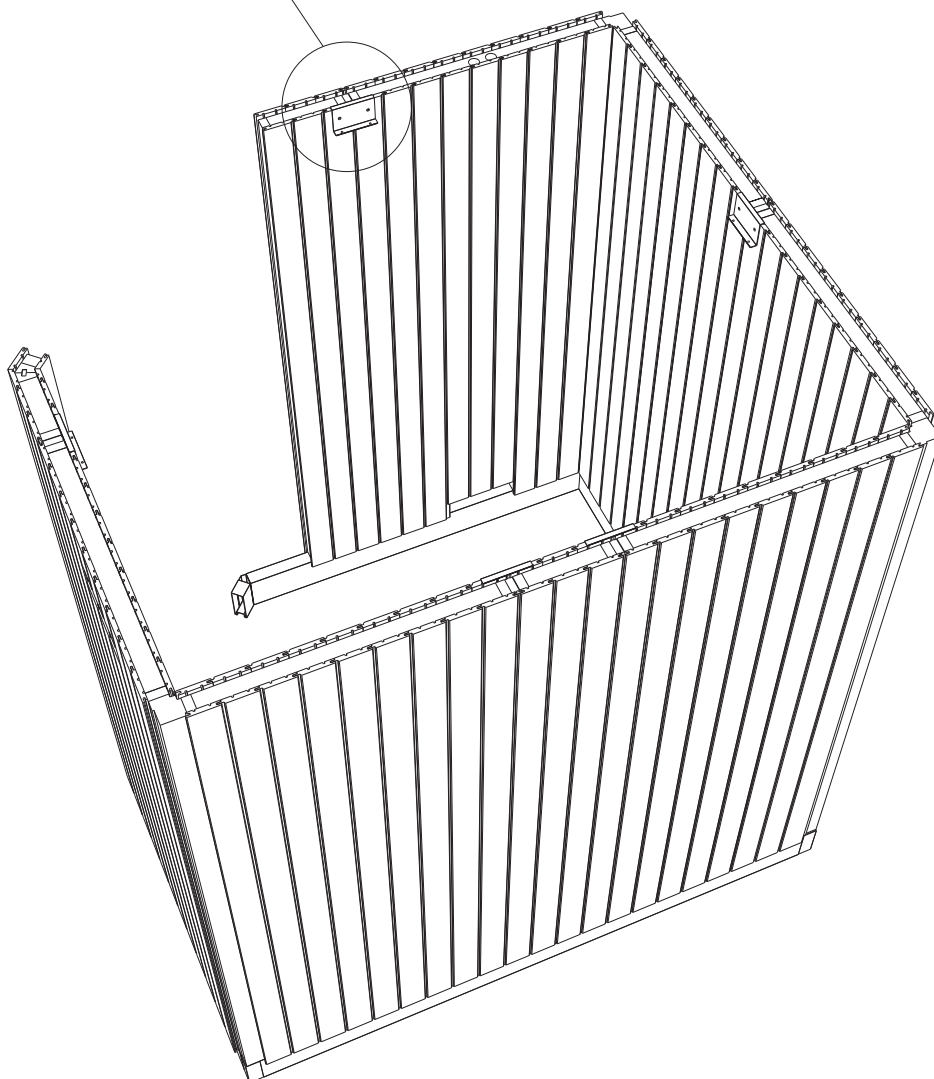
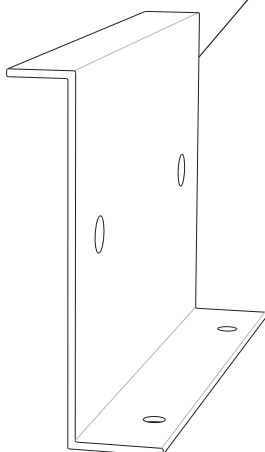
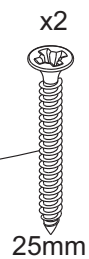
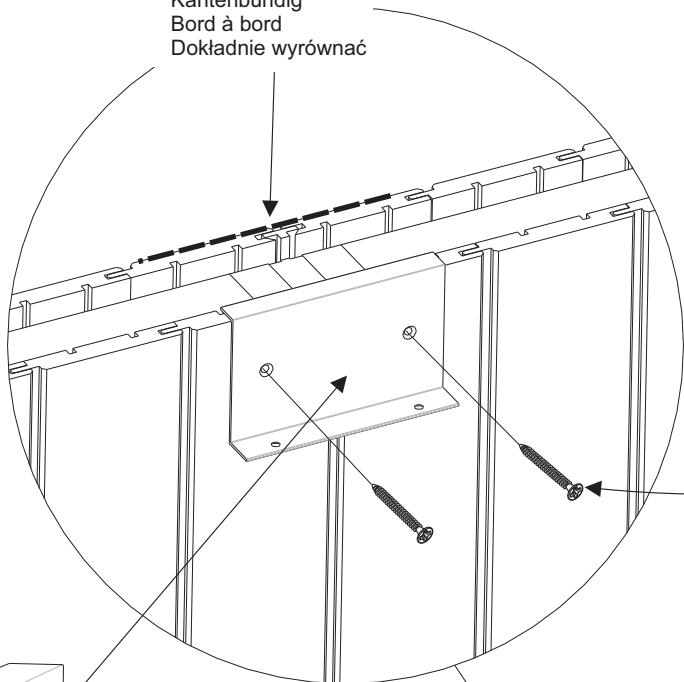
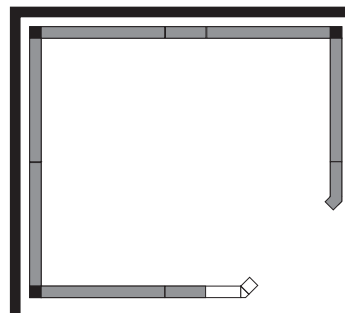



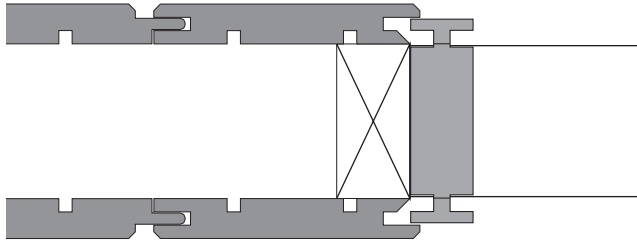
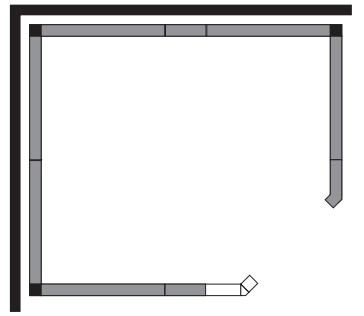

P3



1x1970mm

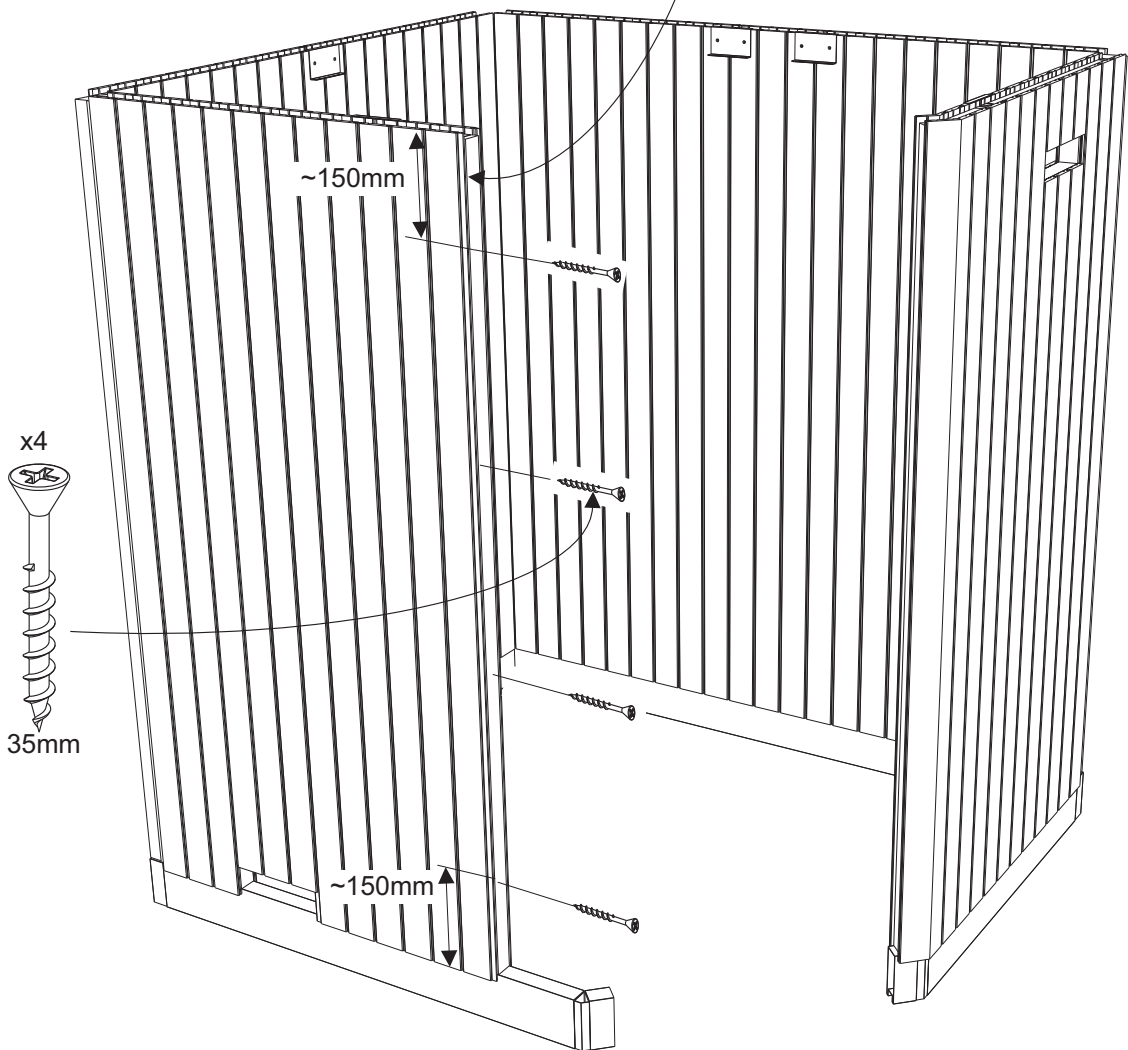

21

Kant i kant  
Flush fitting  
Kantenbündig  
Bord à bord  
Dokładnie wyrównać

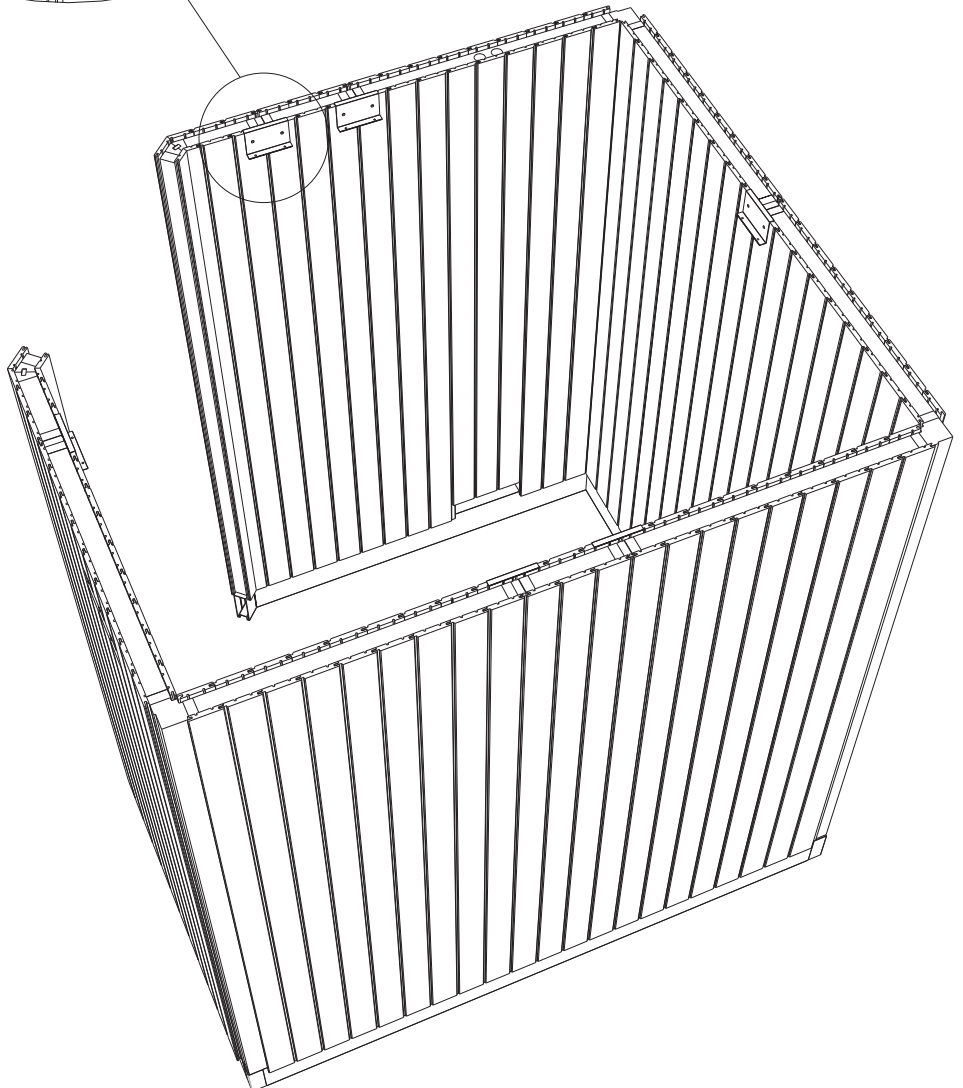
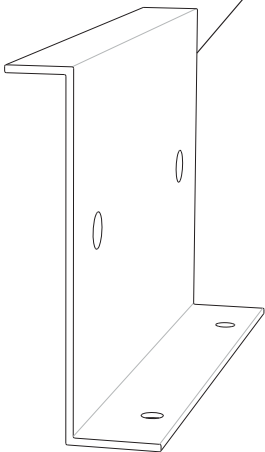
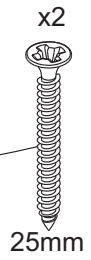
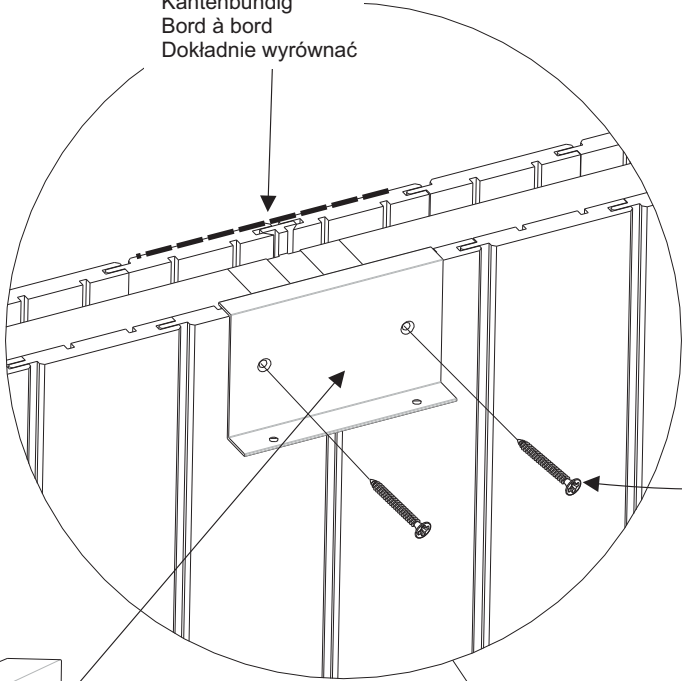
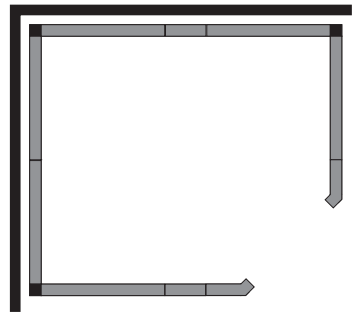

P6

2x1750mm

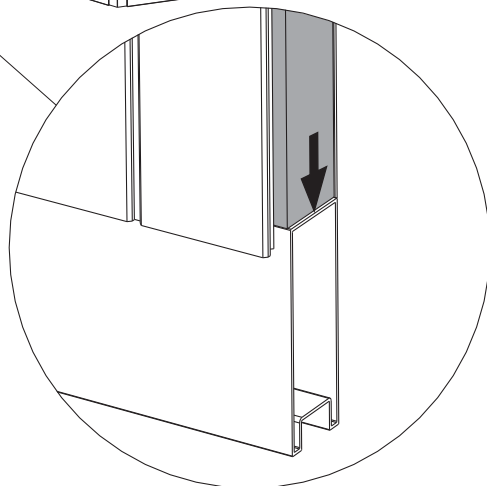
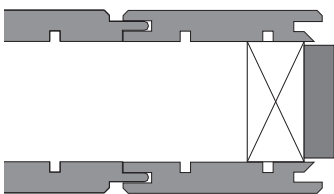
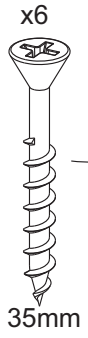
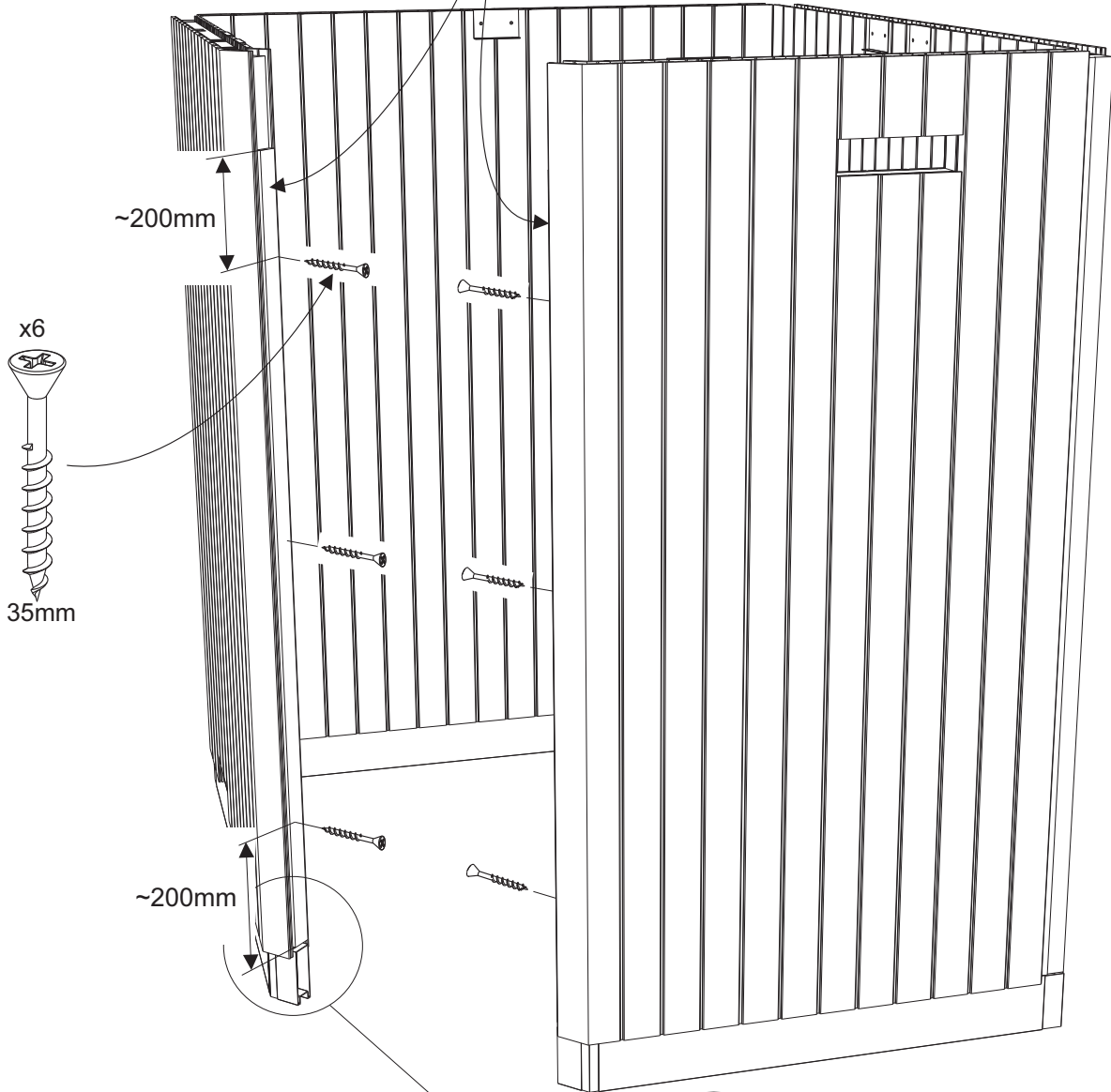
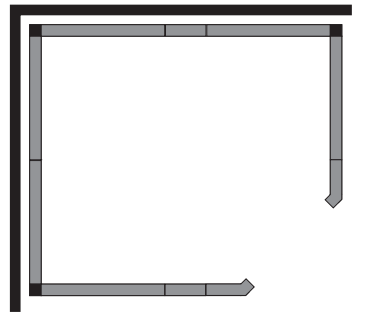

# 23A

## Dörr med tröskel Door with treshold Drzwi z progim

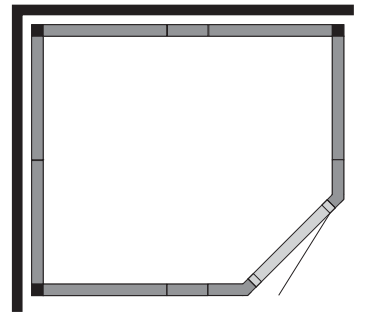

Följ anvisningen som medföljer dörren. Montera därefter tröskelprofil P10.

Follow the instructions supplied with the door. Then assemble the treshold profile P10.

Postępuj zgodnie z instrukcją dołączoną do drzwi. Następnie zamontować próg (profil P10).

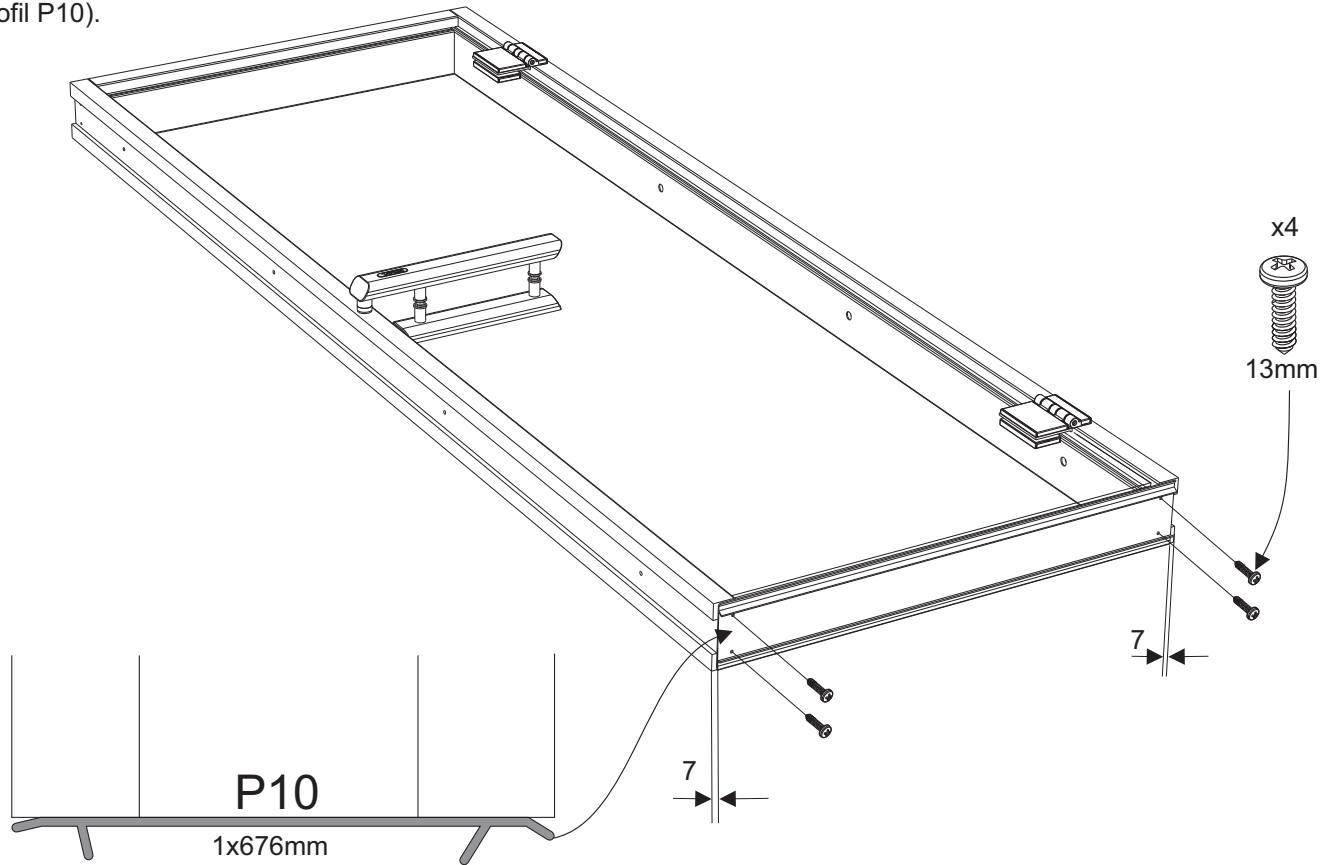

# 23B

## Dörr utan tröskel Door without treshold Drzwi bez prog

Följ anvisningen som medföljer dörren.  
Använd silicon enligt bild 36.

Follow the instructions supplied with the door.  
Use silicon according to picture 36.

Postępuj zgodnie z instrukcją dołączoną do drzwi.  
Zastosowanie silikonu według rys. 36.

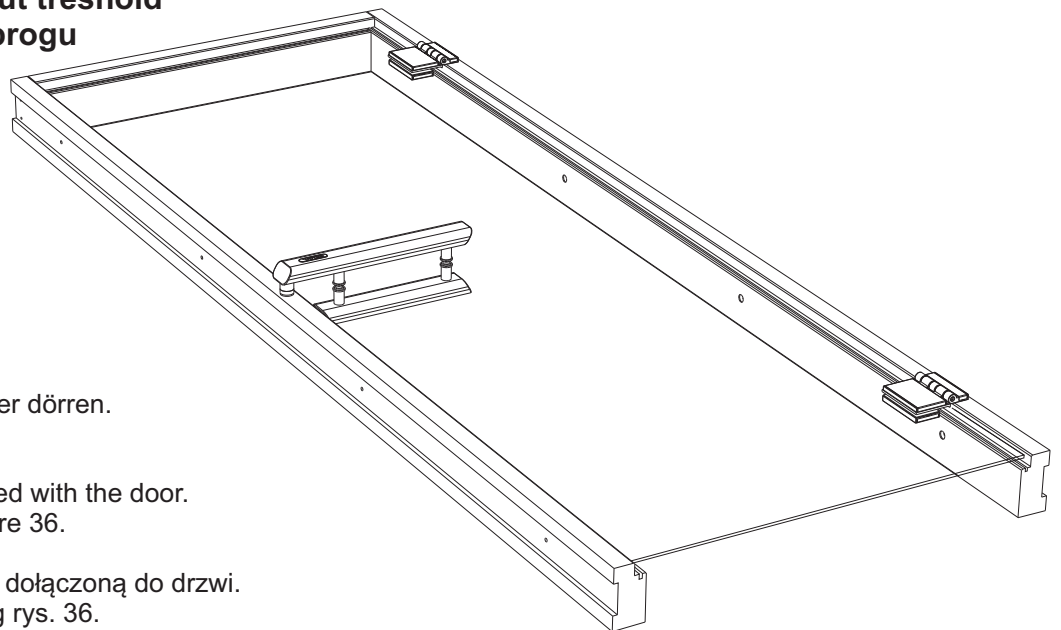

24

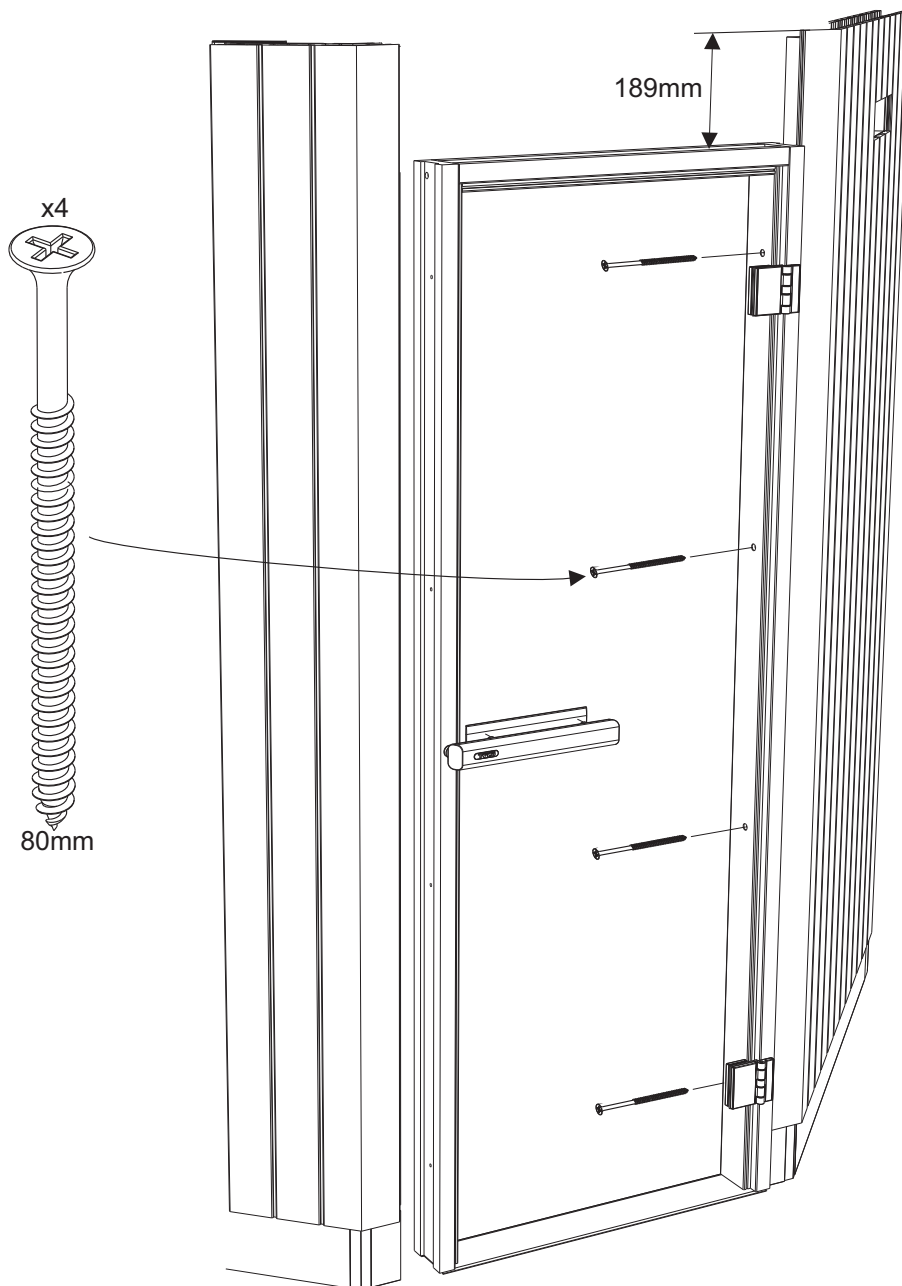
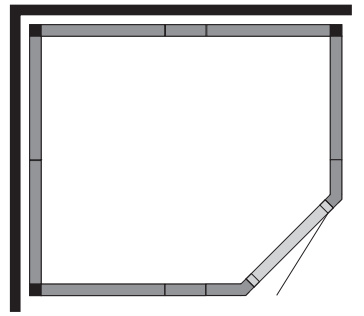
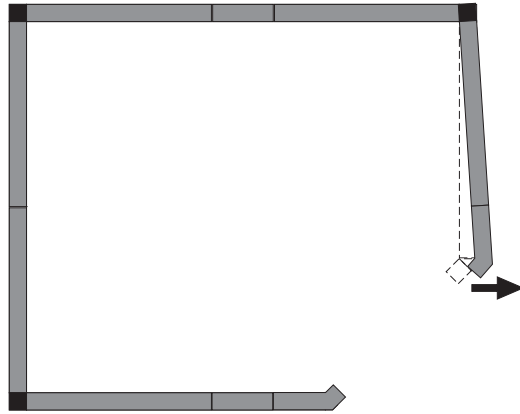

25

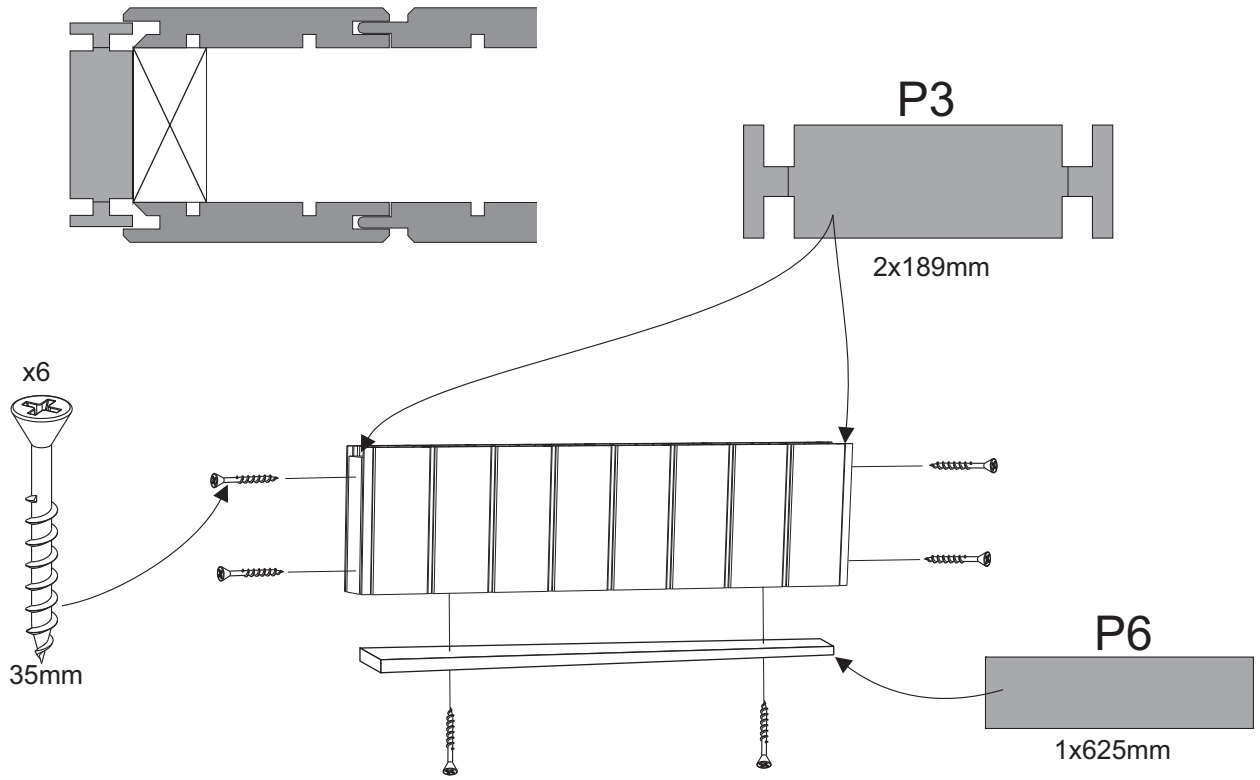

26

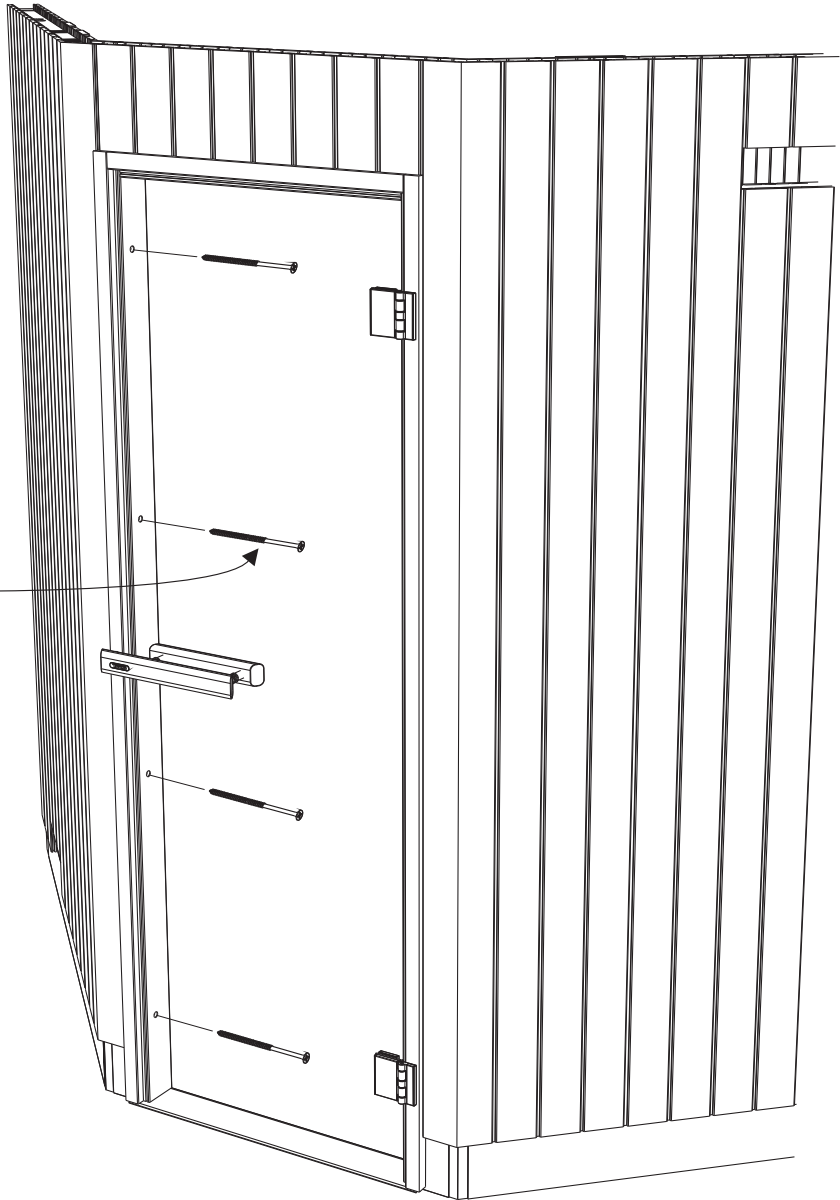
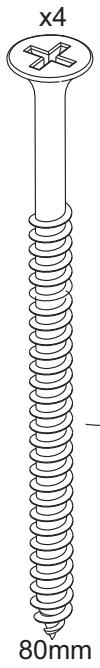
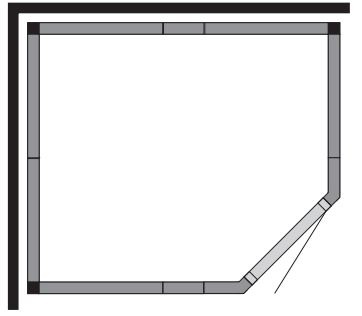
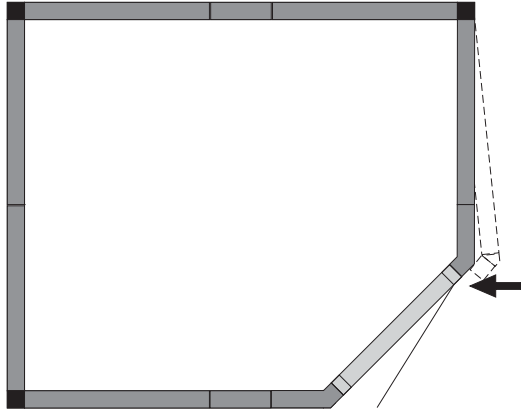

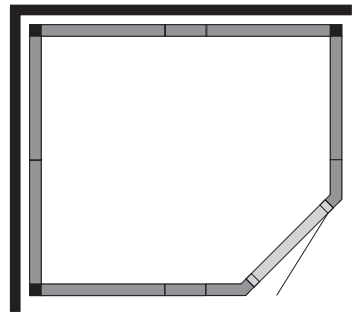

Kant i kant  
 Flush fitting  
 Kantenbündig  
 Bord à bord  
 Dokładnie wyrównać

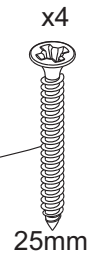
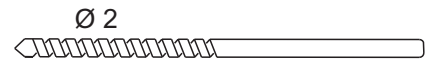
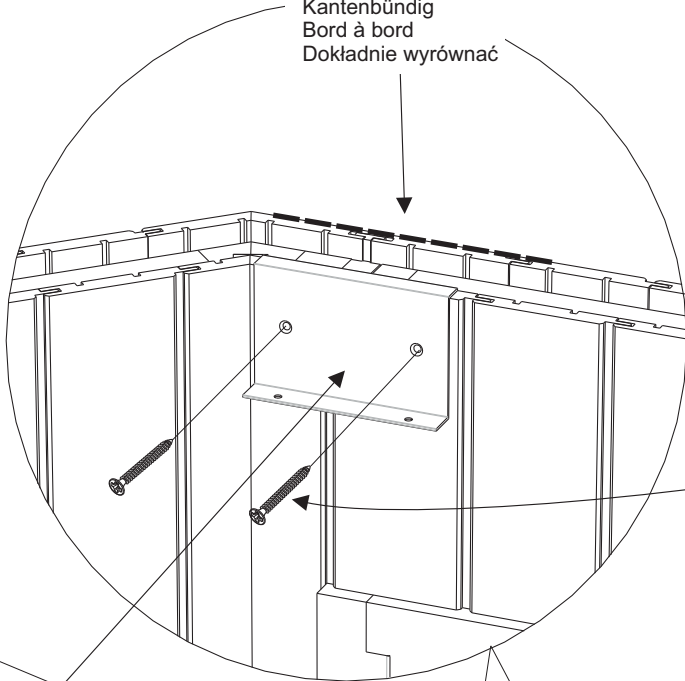

x2

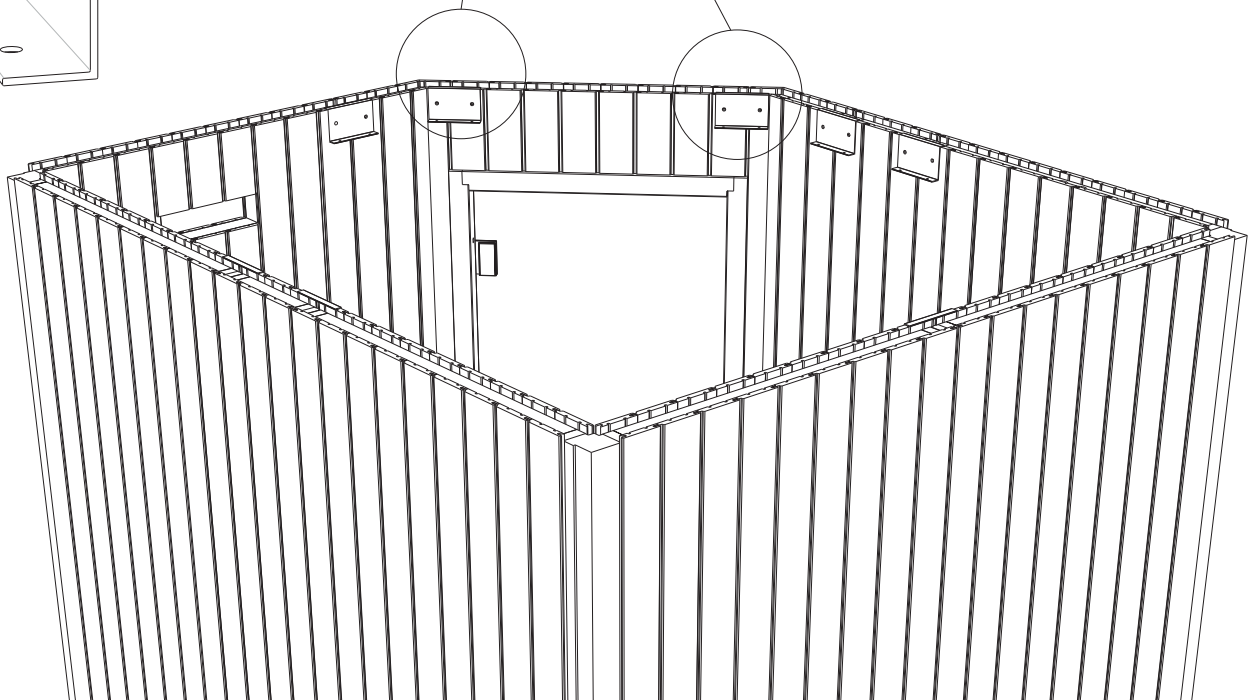
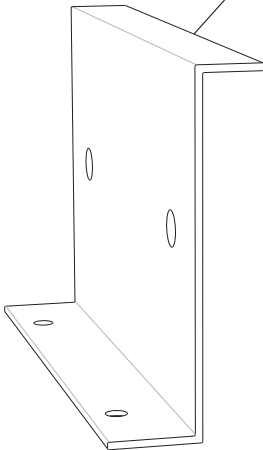



Kant i kant  
 Flush fitting  
 Kantenbündig  
 Bord à bord  
 Dokładnie wyrównać

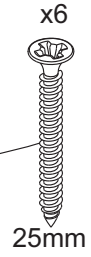
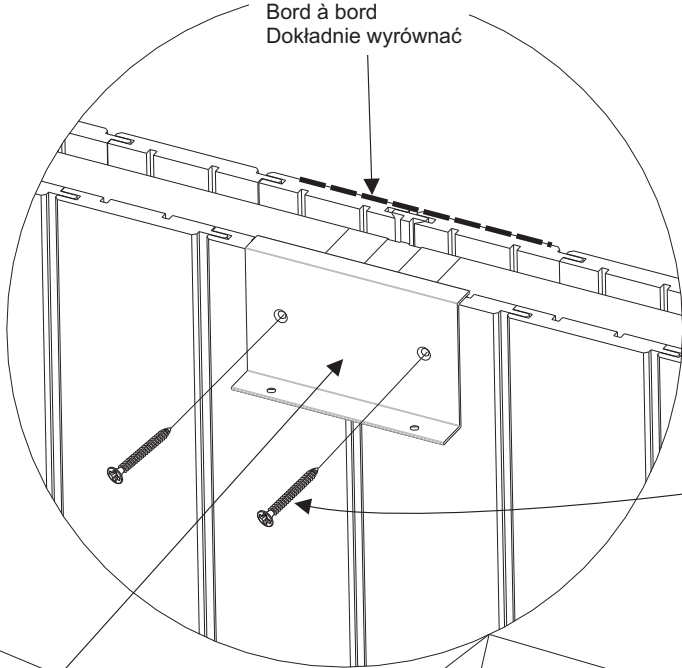
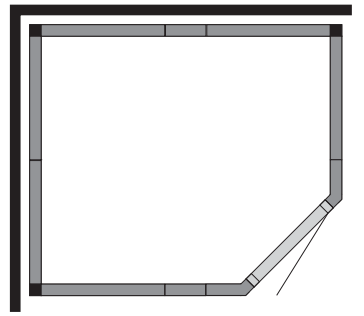

x3

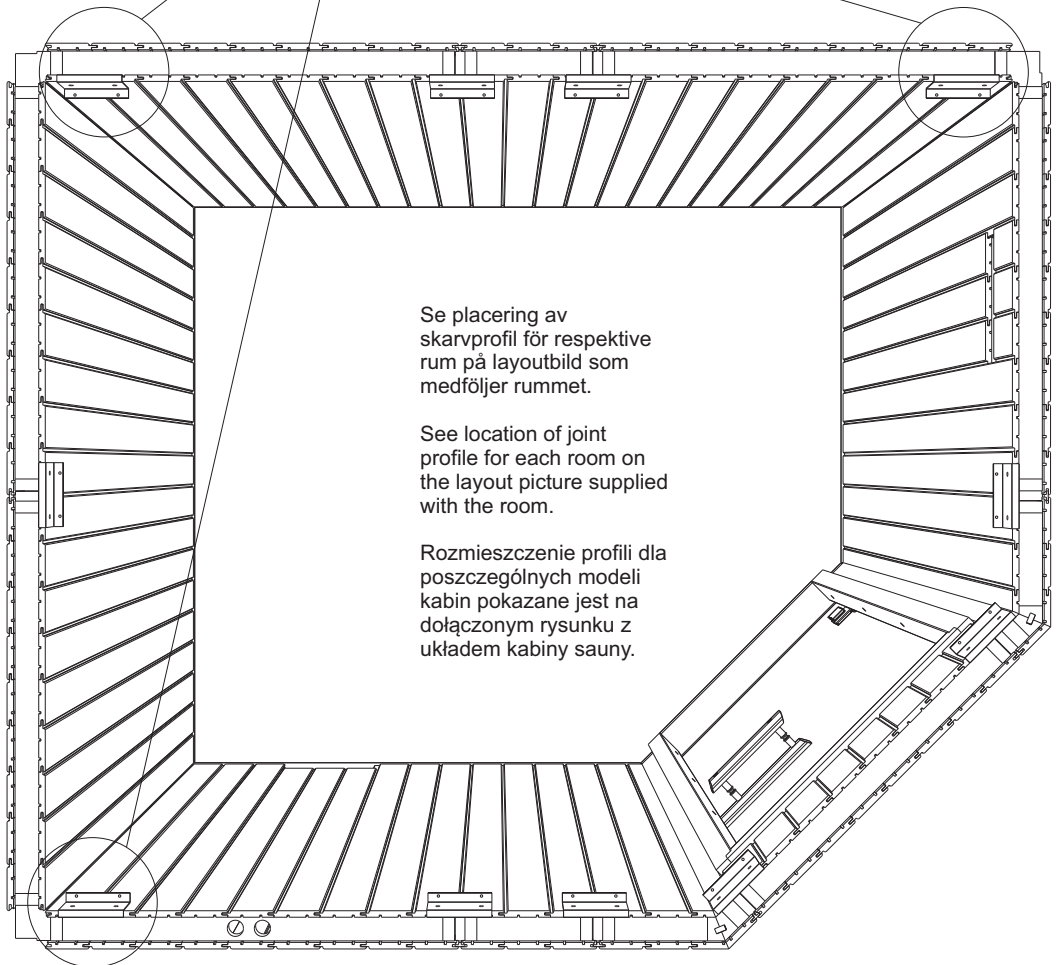
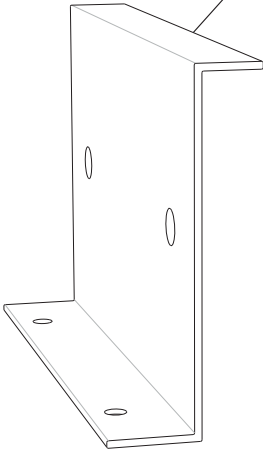

Se placering av skarvprofil för respektive rum på layoutbild som medföljer rummet.

See location of joint profile for each room on the layout picture supplied with the room.

Rozmieszczenie profili dla poszczególnych modeli kabin pokazane jest na dołączonym rysunku z układem kabiny sauny.

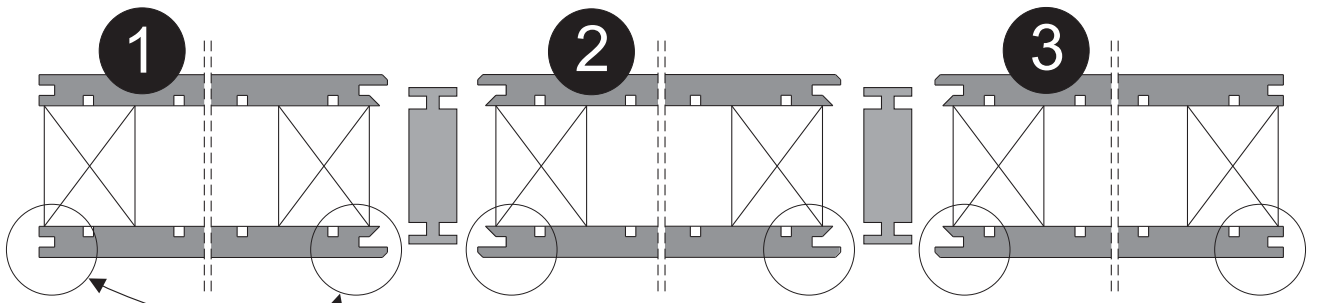
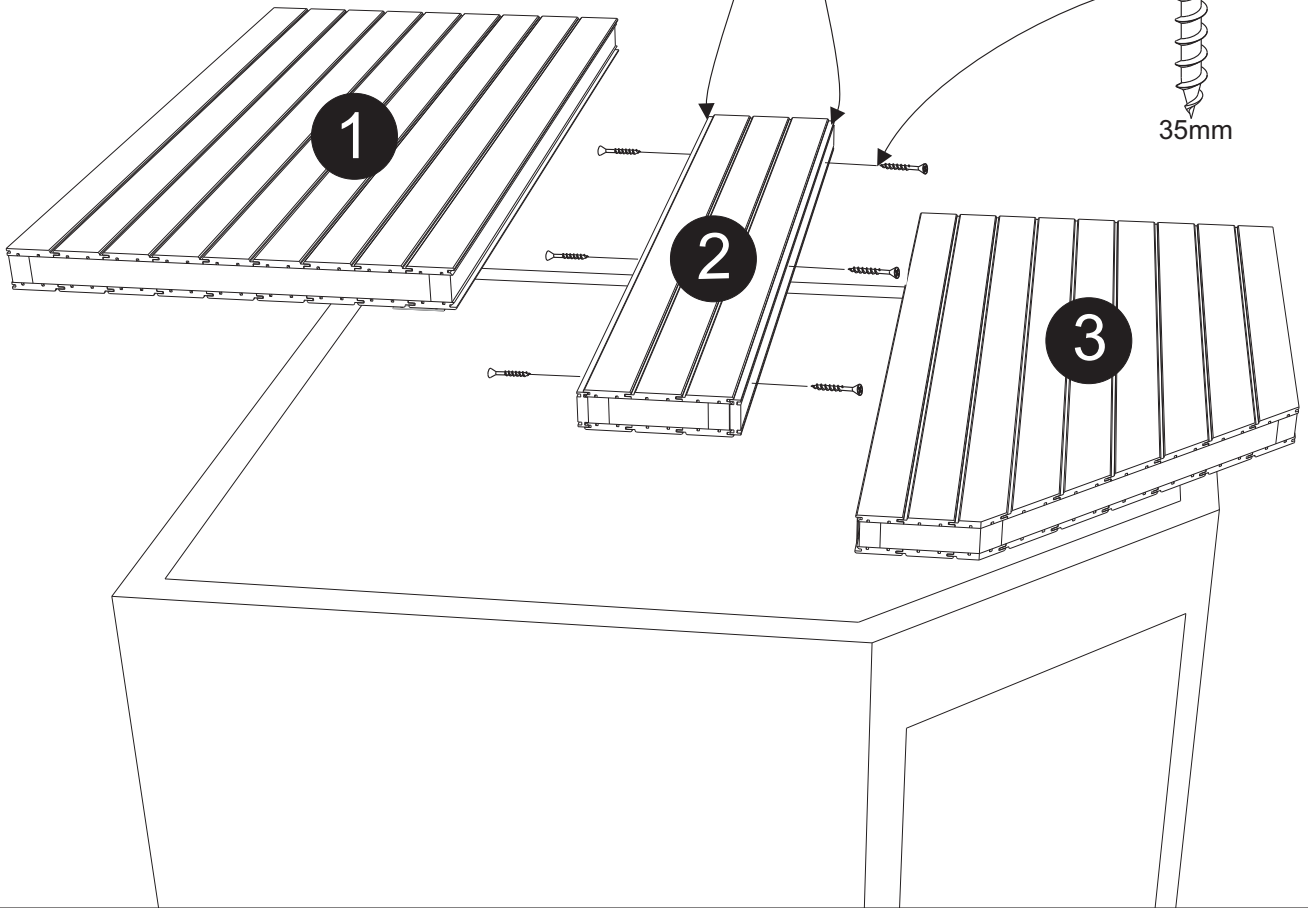
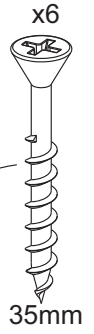
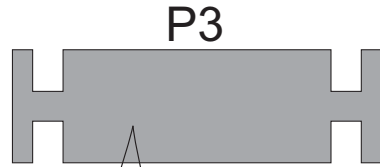
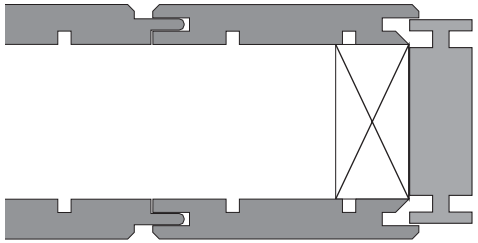
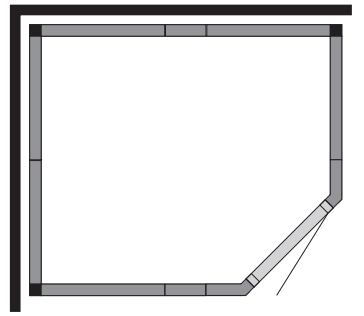

Mot vägg  
Againstst wall  
Do ściany

**OBS!**  
**N.B.!**  
**UWAGA!**

Mot vägg  
Againstst wall  
Do ściany

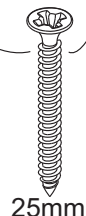
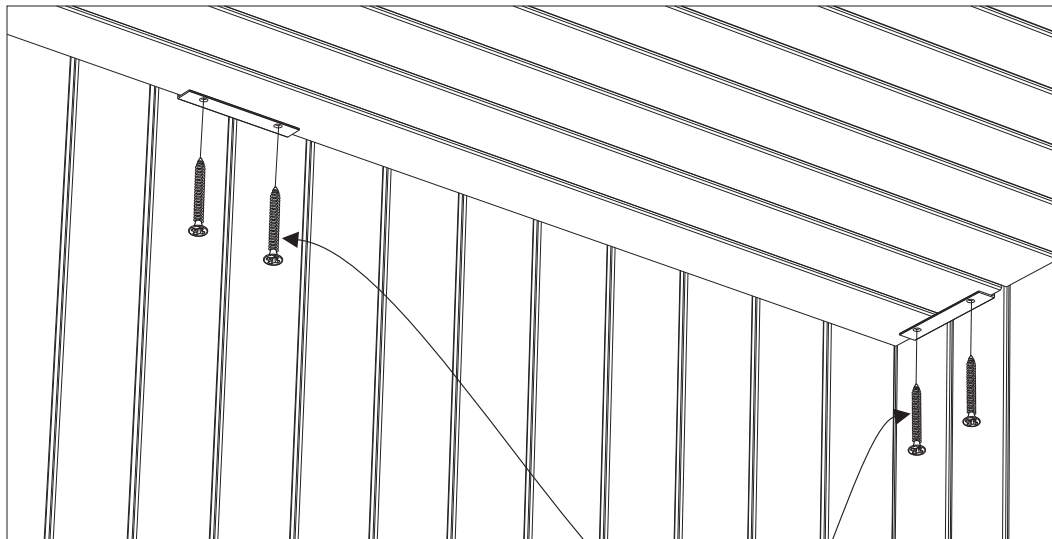
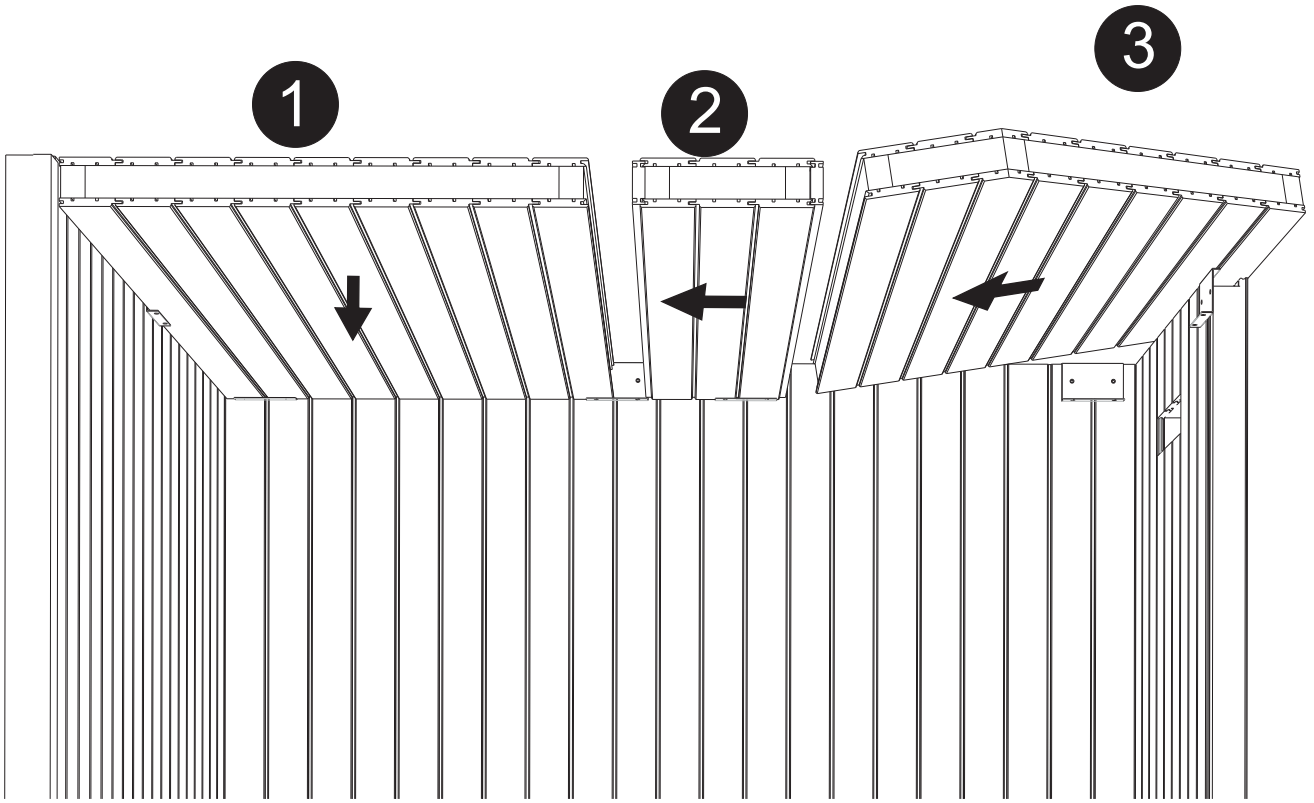
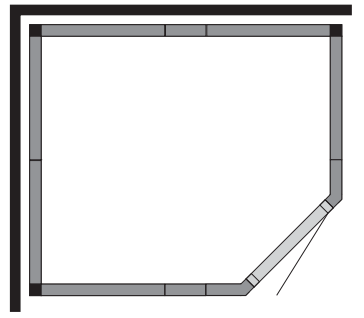

P9

3x1970mm

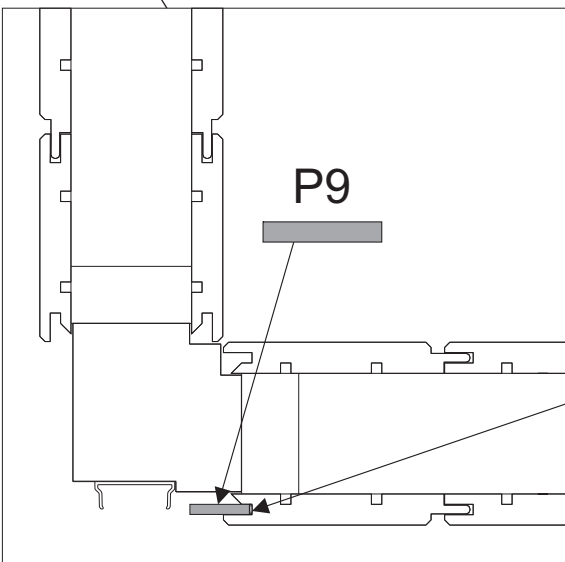
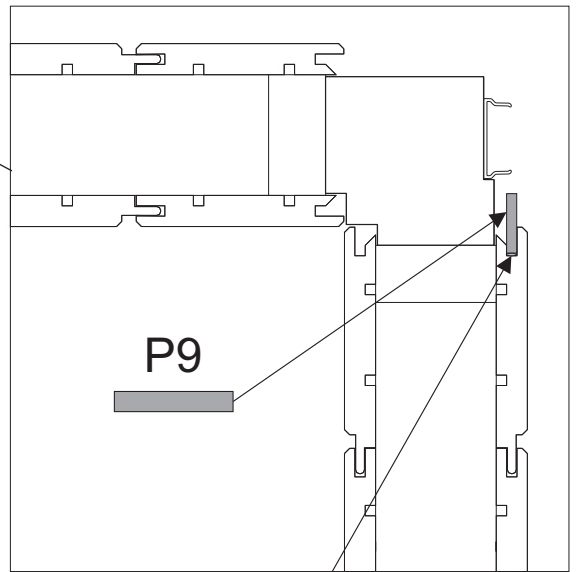
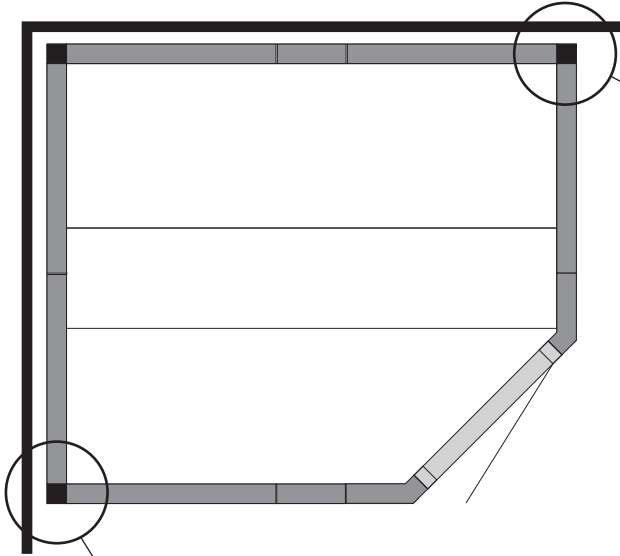
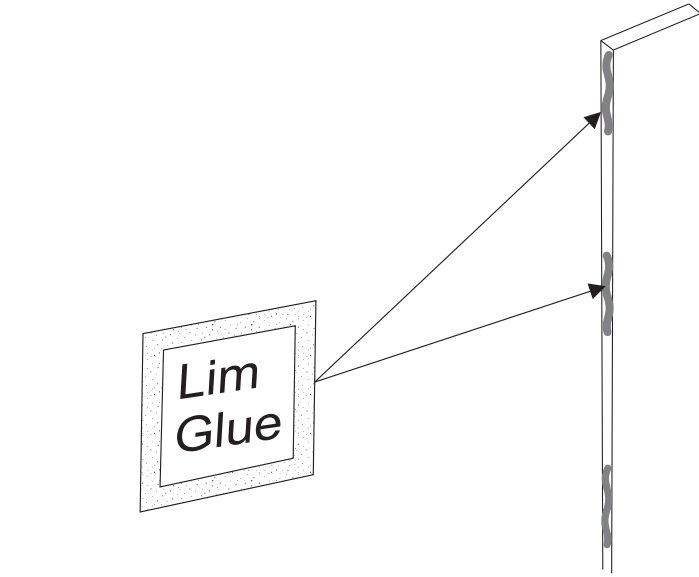
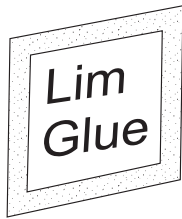

Lim  
Glue  
Klej

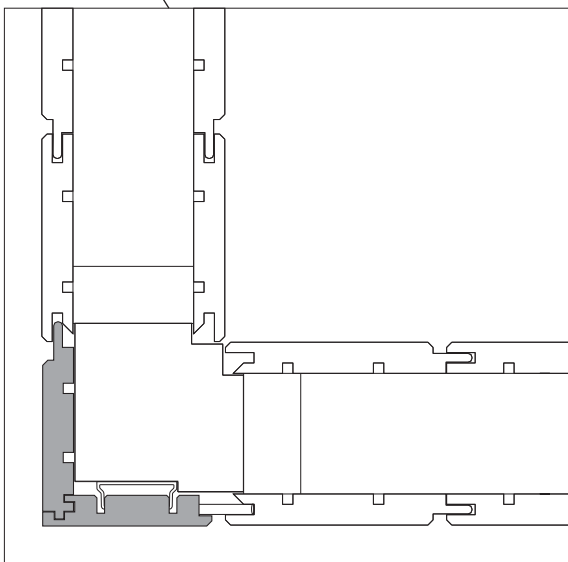
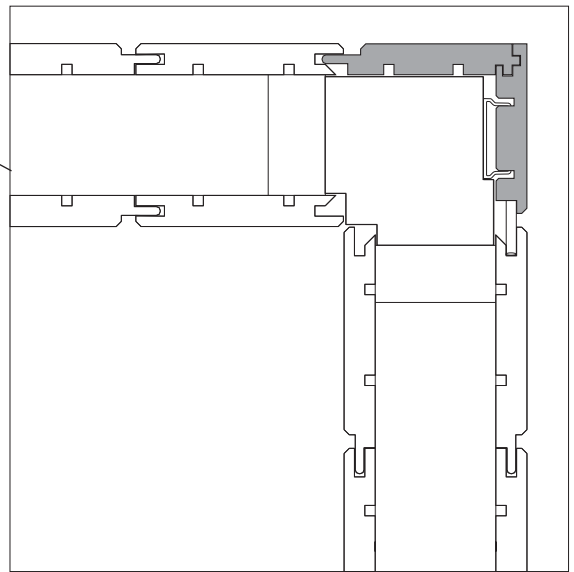
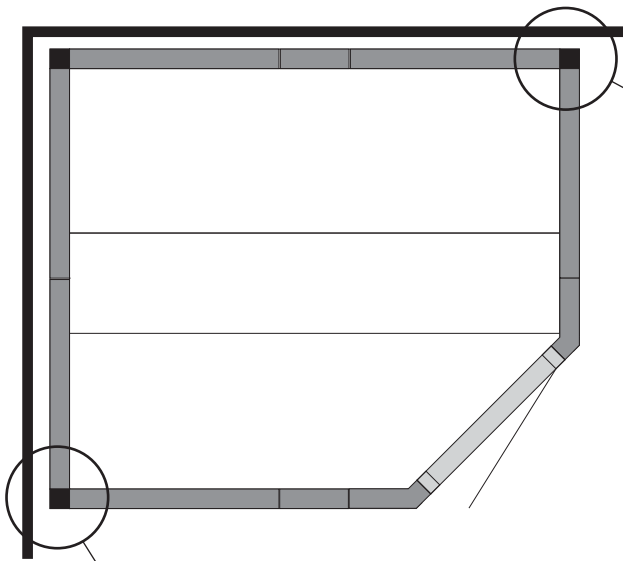
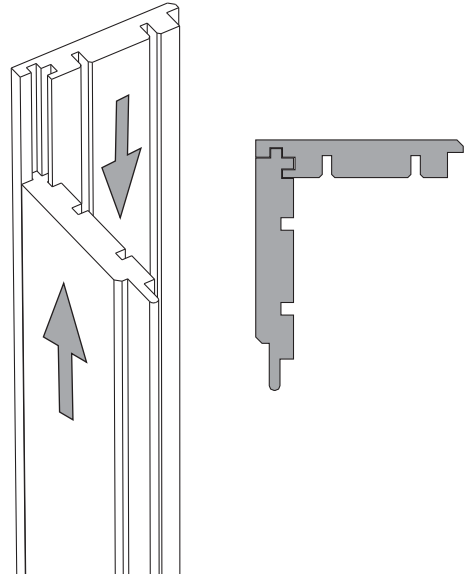
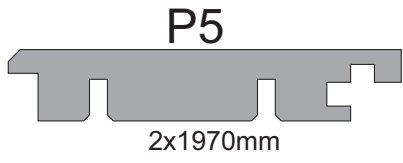
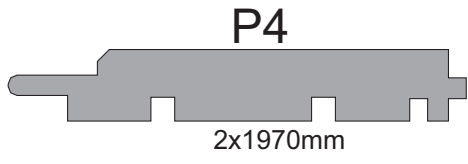

33

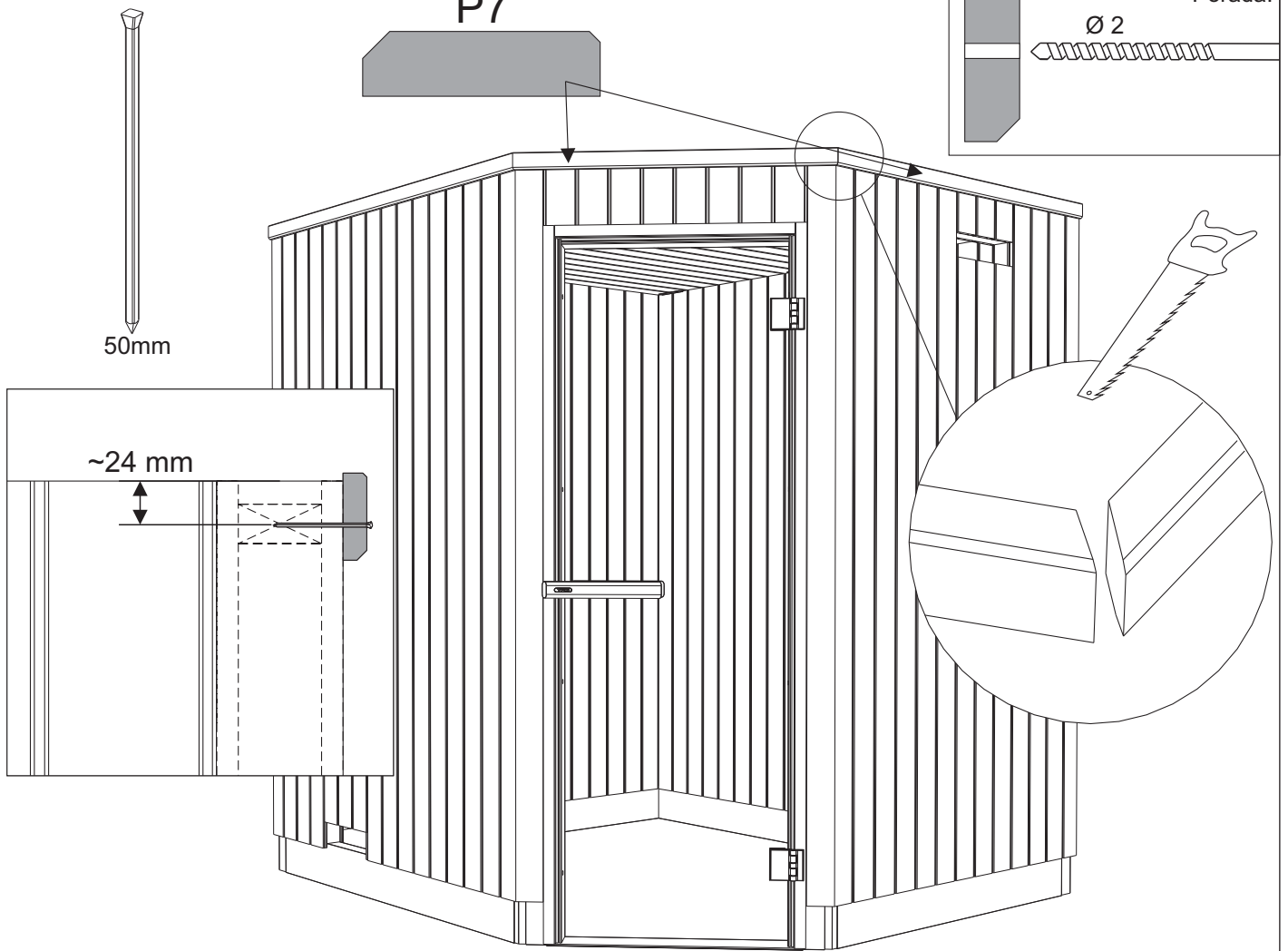

34

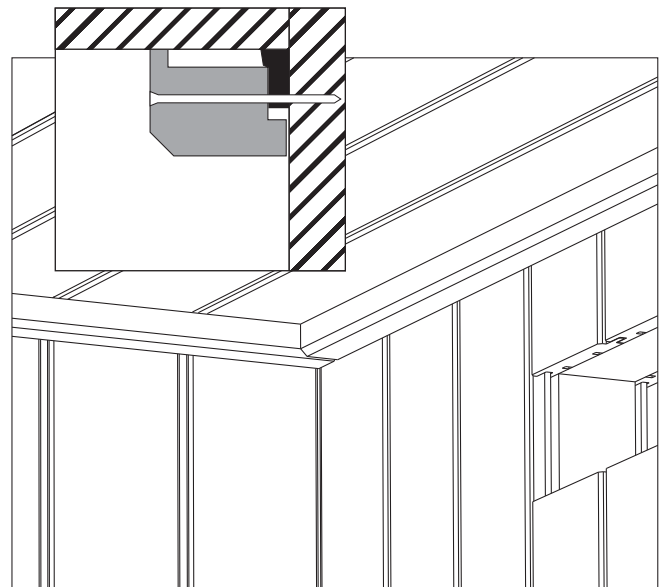
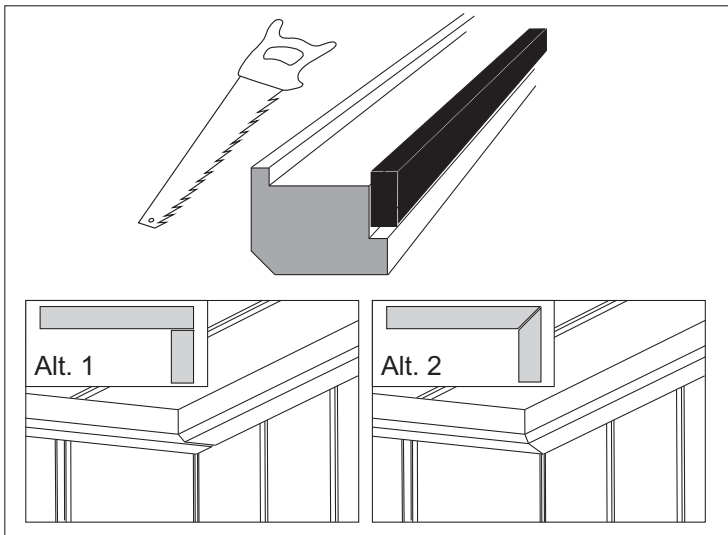
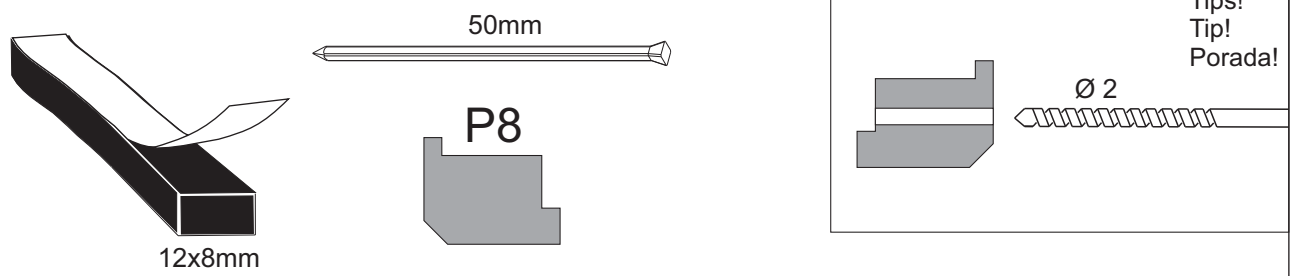

35

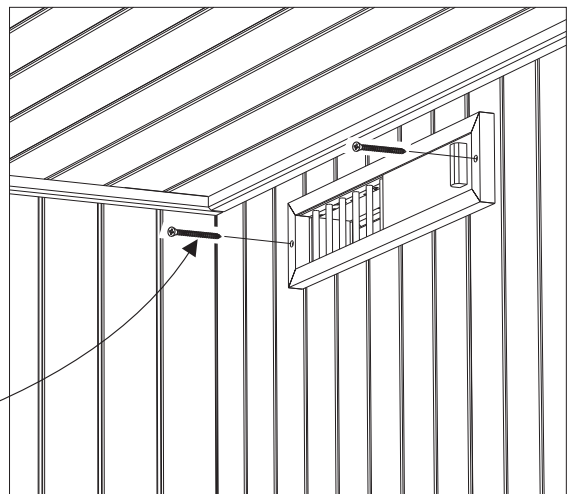
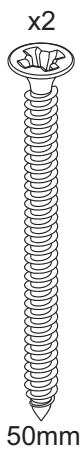
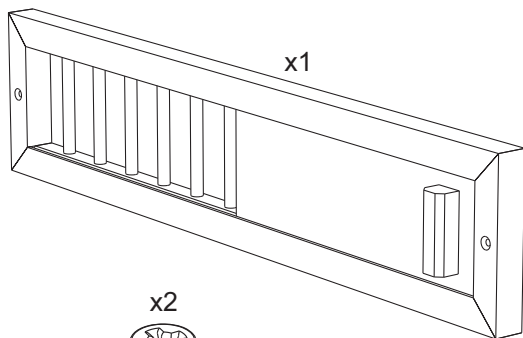
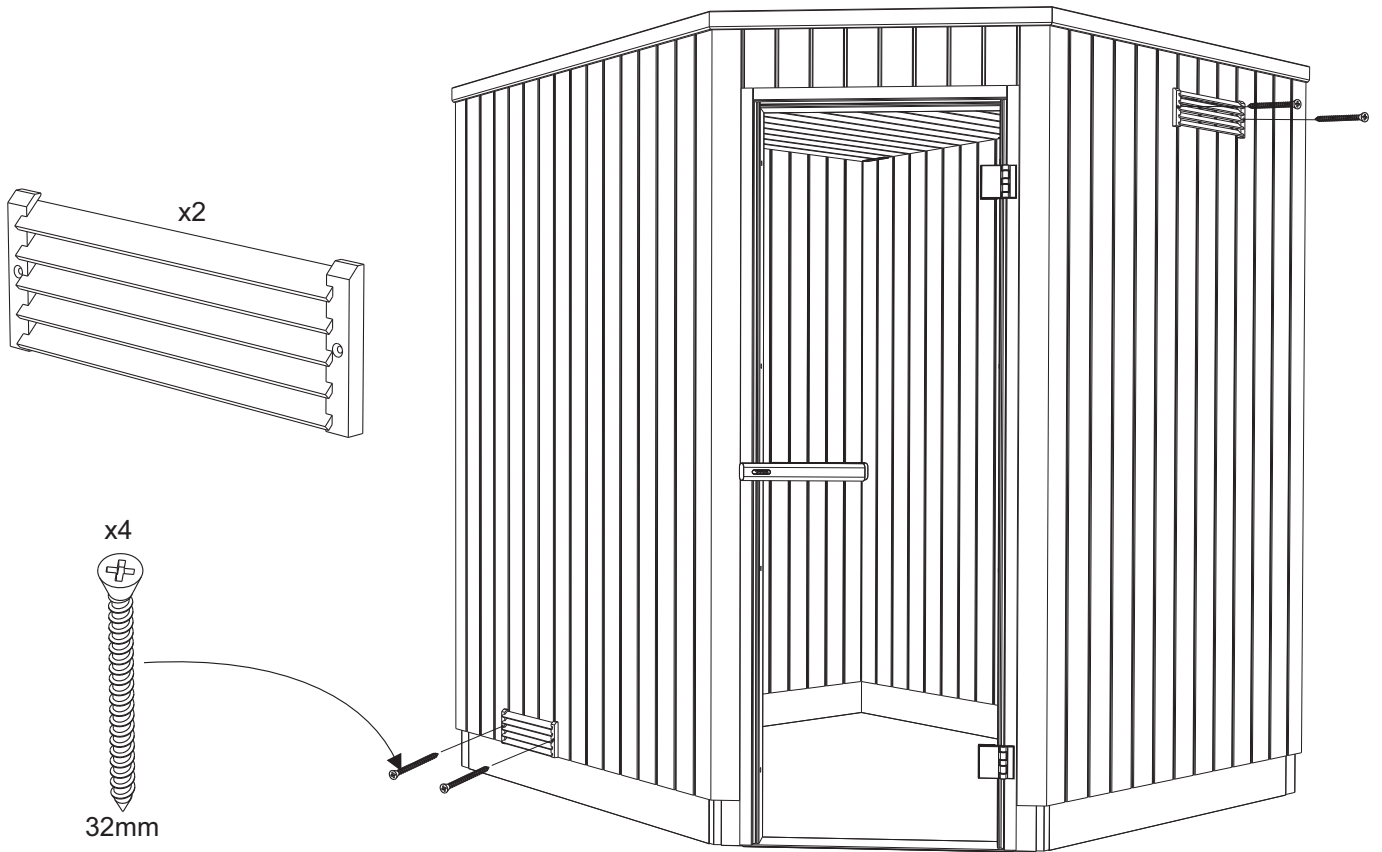

# 36

Använd silikon längs golvprofilen vid montering av dörr utan tröskel (Se bild 23B)

Use silicon along the floor profile when assembling the door without treshold (See picture 23B)

Zastosuj silikon wzdłuż profilu ramy podłogowej przy montażu drzwi bez progów (patrz rys. 23b).

